

# Vacuum Priming Valve

## Operation, Maintenance and Installation Manual

INTRODUCTION.....	2
RECEIVING AND STORAGE.....	2
DESCRIPTION OF OPERATION .....	2
INSTALLATION .....	2
VALVE CONSTRUCTION .....	3
MAINTENANCE.....	4
TROUBLESHOOTING.....	4
DISASSEMBLY .....	4
REASSEMBLY .....	4
OPTIONAL SWITCH .....	5
PARTS AND SERVICE .....	5
WARRANTY .....	5

# VAL-MATIC'S VACUUM PRIMING VALVE OPERATION, MAINTENANCE AND INSTALLATION

## INTRODUCTION

This manual will provide you with the information to properly install and maintain the valve to ensure a long service life. The Vacuum Priming Valve has been designed with stainless steel trim to give years of trouble-free operation. The Vacuum Priming Valve is used in conjunction with a central vacuum priming system to prime (fill with water) a centrifugal pump. The valve is typically mounted on the suction piping or pump volute.

**CAUTION:** This valve is not intended for wastewater service.

The valve is a float-operated, resilient-seated valve designed to handle clean water. The Size, Maximum Working Pressure and Model No. are stamped on the nameplate for reference.

## RECEIVING AND STORAGE

Inspect valves upon receipt for damage in shipment. Handle all valves carefully without dropping. Valves should remain boxed, clean and dry until installed to prevent weather related damage. For long term storage greater than six months, the valve must remain in the box and stored indoors. Do not expose valve to sunlight or ozone for any extended period.

## DESCRIPTION OF OPERATION

The purpose of the Vacuum Priming Valve is to automatically allow air to be drawn out of the pumping system until the pump fills with water. Then, when the water reaches the priming valve, the float rises and closes the priming valve to prevent fluid from flowing to the vacuum priming system. The priming valve will continue to release air while the pump is running.

The valve can be equipped with optional water level control switch to signal when the water level has reached the pump or provide a warning that the pump has lost its prime (wet well is empty of suction line is blocked). The switch is packaged separately for field installation.

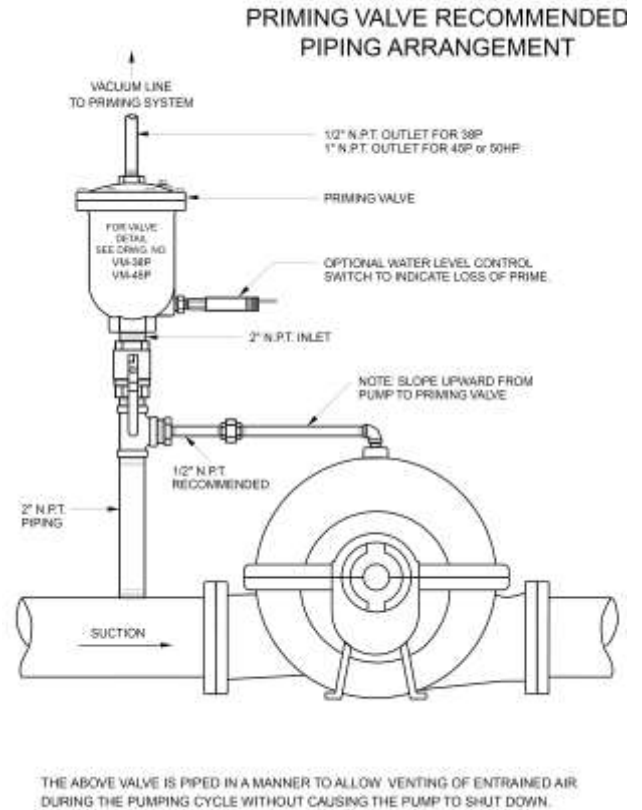

FIGURE 1. RECOMMENDED PIPING

## INSTALLATION

The installation of the valve is important for its proper operation. Valves must be installed on the top of the pump or as shown in Figure 1 with the inlet down. An isolation/shut-off valve should be installed below the valve in the event servicing is required.

## VALVE CONSTRUCTION

The standard Vacuum Priming Valve body and cover are cast iron. See the specific Materials List submitted for the order if other than standard cast iron construction is required. All internal components are stainless steel with the exception of the orifice button, which is resilient.

The lever mechanism provides mechanical advantage for the float. During system operation, the vacuum pressure exerts a strong upward force on the sealing component, the orifice button. The lever mechanism magnifies the weight of the float so that the orifice will open under high pressures and release air. Additional ports are provided for flushing, testing and draining purposes. The general details of construction are illustrated in Figure 2. The body (1) is threaded for connection to the pipeline. The seat (4) is threaded into the cast cover (2).

ITEM	DESCRIPTION	MATERIAL
1	Body	Cast Iron
2	Cover	Cast Iron
3	Leverage Frame*	Stainless Steel
4	Seat*	Stainless Steel
5	Float*	Stainless Steel
6	Gasket*	Non-Asbestos
7	Cover Bolt	Alloy Steel
8	Retaining Screw*	Stainless Steel
10	Float Arm*	Stainless Steel
11	Orifice Button*	Buna-N
12	Pivot Pin*	Stainless Steel
13	Retaining Ring*	Stainless Steel
14	Pipe Plug	Iron
17	Float Retainer*	Stainless Steel
18	Lock Nut*	Stainless Steel
19	Link*	Stainless Steel
20	Extension Shaft*	Stainless Steel
21	Locating Pin*	Stainless Steel
22	Orifice Button Arm*	Stainless Steel
28	Pipe Plug	Malleable Iron
30	Washer*	Stainless Steel
33	Clevis*	Stainless Steel
34	Lock Washer*	Stainless Steel
35	Retaining Screw*	Stainless Steel
36	Pipe Plug	Malleable Iron
*RECOMMENDED REPAIR PART KIT		

TABLE 1. LIST OF PARTS

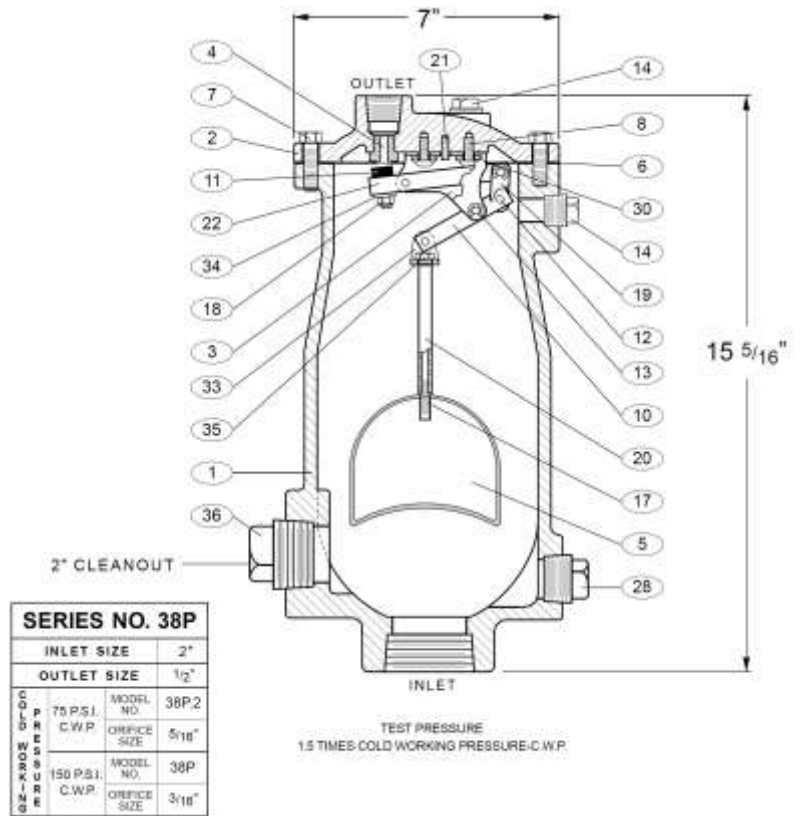

FIGURE 2. VACUUM PRIMING VALVE

## MAINTENANCE

The Vacuum Priming Valve requires no scheduled lubrication or maintenance.

**WARNING:** Wear safety glasses to look into the valve outlet after installation. Released fluid can cause injury.

**Inspection:** Periodic inspection to verify operation can be performed. The valve should not leak fluid at any connection or through the outlet. If there is leakage through the outlet, check for wear on the orifice button (11).

**Lubrication:** The valve is a self-contained automatic valve and does not require and lubrication to enhance its operation.

**Tools:** No special tools are needed to maintain or repair the valve.

## TROUBLESHOOTING

Several problems and solutions are presented below to assist you in troubleshooting the valve assembly in an efficient manner.

- Leakage at Bottom Connection: Tighten valve threaded connection. If leak persists, remove valve and seal threads with Teflon\* sealant.
- Leakage at Cover: Tighten bolts per Table 2, replace gasket (6).
- Valve Leaks when Closed: Disassemble and inspect orifice button (11), and float (5). NOTE: Many floats contain sand for weight but if water is detected, replace float.
- Valve not Venting Air: Check that operating pressure does not exceed Working Pressure on nameplate.

## DISASSEMBLY

The valve can be disassembled without removing it from the pipeline. Or for convenience, the valve can be removed from the line. All work on the valve should be performed by a skilled mechanic with proper tools. No special tools are required.

**WARNING:** The valve must be isolated and drained before removing the cover or pressure may be released causing injury.

1. Close inlet shut-off valve. Open drain valve or remove drain plug. Remove the cover bolts (7) on the top cover.
2. Pry cover (2) loose and lift off valve body.
3. Remove the 2 retainer rings (13) and pivot pins (12) that pass through the lever frame (3). The float (5) and linkage will be free from the cover. Disconnect float from lever (10).
4. To remove lever frame (3), remove two round-head fasteners (8). Rotate seat (4) counter-clockwise to remove.
5. Remove locknut (18) and orifice button (11) from orifice button arm (22).
6. Clean and inspect parts. Note: some floats contain sand for extra weight; if water is detected, replace float. Replace worn parts as necessary and lubricate parts with FDA grease such as Lubriko #CW-606.

## REASSEMBLY

All parts must be cleaned and gasket surfaces should be cleaned with a stiff wire brush in the direction of the serrations or machine marks. Worn parts, gaskets and seals should be replaced during reassembly. Refer to Figure 2.

1. Apply Loctite 680 thread sealant to seat (4) and assemble to cover with maximum torque of 20 ft-lbs; DO NOT OVER-TORQUE.
2. Assemble lever frame (3) to cover over locating pin (21) in cover. Secure with screws (8) and washers (30).
3. Install new orifice button (11) flush to arm (22). Assemble lockwasher (34) and locknut (18) over orifice button but do not tighten.
4. Connect arms (10 & 22) and assemble to lever frame (3) with four pivot pins (12) and retaining rings (13); rings should snap over pins.
5. Adjust orifice button (11) so that orifice button arm

(22) slopes away from cover about 1/16" when resting gently against seat (4). Secure button by tightening lockwasher (34) and nut (18).

6. Attach float (5) and guide shaft (20) by installing last pivot pin (12) into lever frame (3). Float should
7. Lay new cover gasket on clean surface. Assemble gasket (6) and cover (2) over bolt holes in body (1).
8. Insert lubricated bolts (7) and tighten to the torques listed in Table 2.
9. Place valve back in service. Refer to the Installation instructions on page 2. Slowly open inlet isolation valve.

Model Number	Bolt Size	Torque (ft-lbs)
38P	7/16"	30
45P	1/2"	45

**TABLE 2. VALVE COVER BOLT TORQUES**

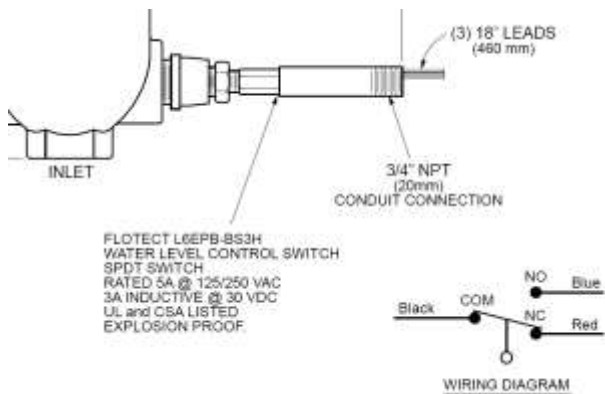

## OPTIONAL WATER LEVEL CONTROL SWITCH

move freely pressing the orifice button (11) against the seat (4) when pushed upward. Verify that all retainer rings (13) are properly secured.

## PARTS AND SERVICE

Parts and service are available from your local representative or the factory. Make note of the valve Model No and Working Pressure located on the valve nameplate and contact:

Val-Matic Valve and Mfg. Corp.  
905 Riverside Drive  
Elmhurst, IL 60126  
PH: 630/941-7600  
FAX: 630/941-8042  
[valves@valmatic.com](mailto:valves@valmatic.com)

A sales representative will quote prices for parts or arrange for service as needed.

### LIMITED WARRANTY

All products are warranted to be free of defects in material and workmanship for a period of one year from the date of shipment, subject to the limitations below.

If the purchaser believes a product is defective, the purchaser shall: (a) Notify the manufacturer, state the alleged defect and request permission to return the product; (b) if permission is given, return the product with transportation prepaid. If the product is accepted for return and found to be defective, the manufacturer will, at his discretion, either repair or replace the product, f.o.b. factory, within 60 days of receipt, or refund the purchase price. Other than to repair, replace or refund as described above, purchaser agrees that manufacturer shall not be liable for any loss, costs, expenses or damages of any kind arising out of the product, its use, installation or replacement, labeling, instructions, information or technical data of any kind, description of product use, sample or model, warnings or lack of any of the foregoing. NO OTHER WARRANTIES, WRITTEN OR ORAL, EXPRESS OR IMPLIED, INCLUDING THE WARRANTIES OF FITNESS FOR A PARTICULAR PURPOSE AND MERCHANTABILITY, ARE MADE OR AUTHORIZED. NO AFFIRMATION OF FACT, PROMISE, DESCRIPTION OF PRODUCT OF USE OR SAMPLE OR MODEL SHALL CREATE ANY WARRANTY FROM MANUFACTURER, UNLESS SIGNED BY THE PRESIDENT OF THE MANUFACTURER. These products are not manufactured, sold or intended for personal, family or household purposes.