

Model TXI7850 Moisture Resistant Electro-Pneumatic Transducer



Features

- Explosion-proof NEMA 4X, IP65, Type 4 enclosure for outdoor and indoor installations.
- Optional tapped exhaust port vents exhaust gas.
- Canadian Registration Numbers (CRN) certification for all territories and provinces.
- Does not contain copper-based metals.
- Compact size for use in restricted areas.
- Internal electronic feedback maintains precise output pressure control.
- Piezoelectric actuator disk provides stability regardless of vibration or position.
- RFI/EMI protection eliminates susceptibility to electromagnetic interference.
- Optional version approved for use with Natural Gas or Industrial Methane as a supply media.
- Encapsulated critical components designed to make unit moisture resistant in tough environments
- Canadian Registration Numbers (CRN) certification for all territories and provinces.
- All TXI7850 products are ROHS compliant.

Operating Principles

The Model TXI7850 Transducer is an electronically controlled pressure sensitive device that converts a current signal to a pneumatic output. This device is composed of the Primary Converting Section and the Relay Section. The Piezoelectric ceramic disk in the Primary Section functions as a flapper. The flapper and the nozzle work together to control the signal pressure in the Relay Section. The signal pressure acts on a diaphragm assembly that controls the pressure in the output chamber.

The output pressure is sensed by the lower control diaphragm to maintain the output pressure. The output pressure is also sensed by the feedback control circuit, which compares the output pressure and input signal (setpoint) to maintain constant output pressure.

The Damping Adjustment on the PC Board allows tuning the transducer for optimum response and stability. Large downstream volumes generally require more damping to achieve output pressure stability.

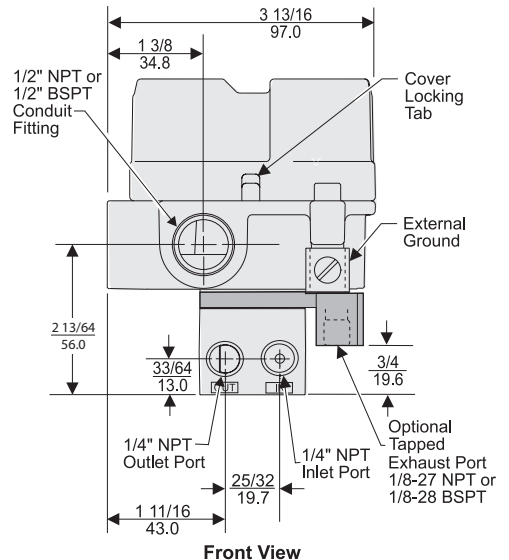
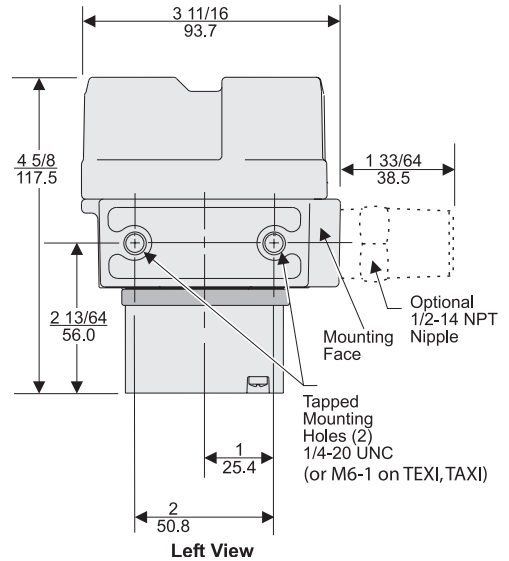
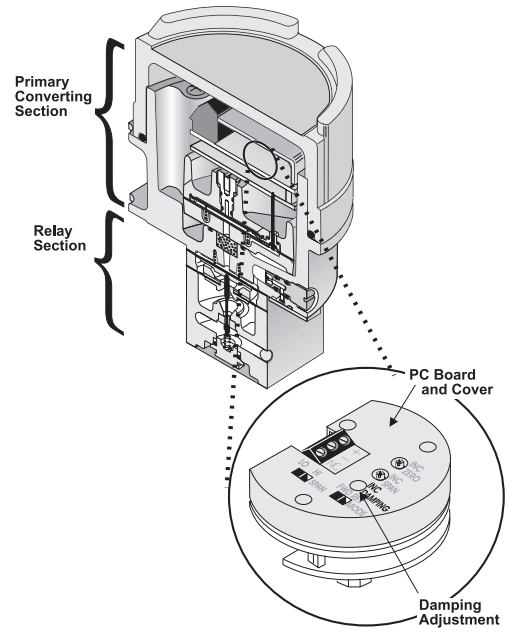

B
Explosion Proof
Model TXI 7850

Model TXI7850 Moisture Resistant Electro-Pneumatic Transducer

Specifications

		SET POINT							
		3 [0.2] (20)		9 [0.6] (60)		15 [1.0] (100)		30 [2.0] (200)	
Maximum Air Consumption	psig [BAR] (kPa) SCFH	1 (0.03 m ³ /HR)	1.3* (0.04 m ³ /HR)	1.9 (0.05 m ³ /HR)	2.5* (0.07 m ³ /HR)	2.5 (0.07 m ³ /HR)	3.2* (0.09 m ³ /HR)	4.2 (0.12 m ³ /HR)	5.4* (0.15 m ³ /HR)
Flow Rate (SCFM)		2.5 (4.25 m ³ /HR) @ 25 psig, [1.7 BAR], (170 kPa) supply & 9 psig, [0.6 BAR], (60 kPa) Output				9.0 (15.3 m ³ /HR) @ 120 psig, [8.0 BAR], (800 kPa) supply & 9 psig, [0.6 BAR], (60 kPa) Output			
Temperature Range	Operating Storage	-40°F to + 160°F, (-40°C to + 71.2°C) -40°F to + 180°F, (-40°C to + 82.2°C)							
Span/Zero Adjustments		Screwdriver adjustments located under cover							
		OUTPUT RANGE							
		3-15 [0.2-1.0] (20-100)		3-27 [0.2-1.8] (20-180)		6-30 [0.4-2.0] (40-200)			
Input Range		4-20 mA							
Supply Pressure ^{1,2}		20-120 [1.5-8.0] (150-800)		32-120 [2.2-8.0] (220-800)		35-120 [2.4-8.0] (240-800)			
Minimum Span		5 [0.35] (35)		10 [0.7] (70)		10 [0.7] (70)			
Frequency Response		-3 db @ 5 Hz per ISA S26.4.3.1 load configuration A.							
Required Operating Voltages		8.2 VDC @ 20 mA (4-20 mA signal)							
Accuracy (ISA S51.1)		0.25% Full Scale Guaranteed 0.15% Full Scale Typical							
Hysteresis (ISA S51.1)		≤ 0.1% Full Scale							
Deadband		≤ 0.02% Full Scale							
Repeatability (ISA S51.1)		≤ 0.1% Full Scale							
Position Effect		No Measurable Effect							
Vibration Effect		Less than ±1% of Span under the following conditions: 5-15 Hz @ 0.75 inches constant displacement 15-500 Hz @ 10 Gs.							
Reverse Polarity Protection		No damage occurs from reversal of normal supply current (4-20 mA) or from misapplication of up to 60 mA.							
RFI/EMI Effect		Less than 0.5% of span @ 30 ^v /m class 3 Band ABC (20-1000 mHz) per SAMA PMC 33.1 1978 and less than 0.5% of Span @ 10 ^v /m level, to 2 GHz Band per EN 61000-4-3:1998 +A1 EMC Directive 89/336/EEC European Norms EN 61326							
Supply Pressure Effect		No Measurable Effect							
Temperature Effect		[+0.5% +0.04% / °F Temperature Change] of Span typical							
Materials of Construction		Body and Housing Chromate Treated Aluminum Orifice Aluminum & Sapphire Trim Stainless Steel & Zinc Plated Steel Elastomers Nitrile Finish Epoxy Powder Coating							

¹ Supply Pressure must be no less than 5 psig, [0.35 BAR], (35 kPa), above maximum output.

² Unit with "N" option 125 psig, [8.5 BAR], (850 kPa) for air or Group IIA Gases.

*With Natural Gas Media

Model TXI7850 Moisture Resistant Electro-Pneumatic Transducer

Extended Range Specifications

		SET POINT									
psig [BAR] (kPa)		0 [0] (0)		15 [1.0] (100)		30 [2.0] (200)		60 [4.0] (400)		120 [8.0] (800)	
Maximum Air Consumption	0-30 psig SCFH	1 (0.03 m ³ /HR)	1.3* (0.04 m ³ /HR)	2.8 (0.08 m ³ /HR)	3.6* (0.10 m ³ /HR)	4.2 (0.12 m ³ /HR)	5.4* (0.15 m ³ /HR)				
	0-60 psig SCFH	1.6 (0.4 m ³ /HR)		4.7 (.13 m ³ /HR)		7.8 (.22 m ³ /HR)		13.3 (.37 m ³ /HR)			
	0-120 psig SCFH	0.5 (.01 m ³ /HR)				3.8 (.11 m ³ /HR)		7.6 (.21 m ³ /HR)		15.1 (.42 m ³ /HR)	
Flow Rate (SCFM)		11.0 (18.7 m ³ /HR) @ 150 psig, [10 BAR], (1000 kPa) supply & midscale output									
Temperature Range	Operating Storage	-40°F to + 160°F, (-40°C to + 71.2°C) -40°F to + 180°F, (-40°C to + 82.2°C)									
Span/Zero Adjustments		Screwdriver adjustments located on front of unit									
Required Operating Voltages		Two Wire Current Input 8.2 VDC @ 20 mA (4-20 mA signal)									
Signal Impedance		Three Wire Voltage Input 10 Kilohms									

B

Model
TXI
7850

Explosion Proof

OUTPUT RANGE

psig [BAR] (kPa)	0-30 [0-2.0] (0-200)	0-60 [0-4.0] (0-400)	0-120 [0-8.0] (0-800)
Input Range	4-20 mA DC		
Supply Pressure ^{1,2}	35-150, [2.4-10], (240-1000)	65-150, [4.6-10], (460-1000)	125-150, [8.8-10], (880-1000)
Minimum Span	12.5 [0.85] (85)	25 [1.5] (150)	50 [3.0] (300)
Frequency Response	-3 db @ 2 Hz per ISA S26.4.3.1 load configuration A.		
Accuracy (ISA S51.1)	0.25% Full Scale Guaranteed 0.15% Full Scale Typical		
Hysteresis (ISA S51.1)	0.25% Full Scale		
Deadband	0.02% Full Scale		
Repeatability (ISA S51.1)	0.1% Full Scale		
Position Effect	0.125% @ 90° & 0.25% @ 180°		
Vibration Effect	Less than +1% of Span under the following conditions: 5-15 Hz @ 0.8 inches constant displacement 15-500 Hz @ 10 Gs.		
Reverse Polarity Protection	No damage occurs from reversal of normal supply current (4-20 mA) or from misapplication of up to 60 mA.		
RFI/EMI Effect	Less than 0.5% of span @ 30 ^v /m class 3 Band ABC (20-1000 mHz) per SAMA PMC 33.1 1978 and less than 0.5% of Span @ 10 ^v /m level, to 2 GHz Band per EN 61000-4-3:1998 +A1 EMC Directive 89/336/EEC European Norms EN 61326		
Supply Pressure Effect	< 0.1 psig change for 10 psig supply change		
Temperature Effect	[+0.5% +0.06% / °F Temperature Change] of Span typical		
Materials of Construction	Body and Housing Chromate Treated Aluminum Orifice Nickel Plated Brass & Sapphire Trim Stainless Steel & Zinc Plated Steel Elastomers Nitrile Finish Epoxy Powder Coating		



¹ Supply Pressure must be no less than 5 psig, [0.35 BAR], (35 kPa), above maximum output

² Unit with "N" option 125 psig, [8.5 BAR], (850 kPa) for air or Group IIA Gases

*With Natural Gas Media

Model TXI7850 Moisture Resistant Electro-Pneumatic Transducer

Hazardous Area Classifications

	Explosion-Proof	Intrinsically Safe														
Factory Mutual (FM) Approvals 	Air as supply pressure media Class I, Division 1, Groups B, C and D; Class II, Division 1, Groups E, F and G; Class III, Division 1, Fibers; Class I, Division 2, Groups A, B, C and D; Max. Ambient 65°C; Temperature Code T5; NEMA 4X Enclosure.	Air as supply pressure media Class I, II, III, Division 1, Groups C, D, E, F & G, Fibers NEMA 4X Enclosure; Temperature Code T4 (Ta -40°C to +80°C, Entity) 1/0 AEx ia IIB T4 (Ta -40°C to +80°C)														
	Group D gases, including Natural Gas as supply pressure media Class I, Division 1, Groups C and D; Class II, Division 1, Groups E, F and G; Class I, Division 2, Groups A, B, C and D; Class II, Division 2, Groups E, F and G.	<table border="1"> <thead> <tr> <th colspan="2">Entity Parameters</th> </tr> </thead> <tbody> <tr> <td>V_{max}¹ = 30 VDC</td> <td>C_i³ = Zero</td> </tr> <tr> <td>I_{max}² = 200 mA</td> <td>L_i⁴ = Zero</td> </tr> <tr> <td>¹V_{max} = Max. Voltage</td> <td>³C_i = Capacitance</td> </tr> <tr> <td>²I_{max} = Max. Current</td> <td>⁴L_i = Inductance</td> </tr> </tbody> </table>	Entity Parameters		V _{max} ¹ = 30 VDC	C _i ³ = Zero	I _{max} ² = 200 mA	L _i ⁴ = Zero	¹ V _{max} = Max. Voltage	³ C _i = Capacitance	² I _{max} = Max. Current	⁴ L _i = Inductance				
Entity Parameters																
V _{max} ¹ = 30 VDC	C _i ³ = Zero															
I _{max} ² = 200 mA	L _i ⁴ = Zero															
¹ V _{max} = Max. Voltage	³ C _i = Capacitance															
² I _{max} = Max. Current	⁴ L _i = Inductance															
Canadian Standards Association (CSA) Approvals 	Air as supply pressure media Class I, Division 1, Groups B, C and D; Class II, Division 1, Groups E, F and G; Class I, Division 2, Groups A, B, C and D; Class II, Division 2, Groups E, F and G. Max. Ambient 65°C; Temperature Code T5; Type 4X Enclosure.	Air as supply pressure media Class I, Division 1, Groups C and D; Class II, Division 1, Groups E, F and G; Temperature Code T4A (Ta -40°C to +66°C) Type 4X Enclosure; T6 (Ta -40°C to +40°C). Rated 4-20 mA, 30 VDC maximum														
	Group D gases, including Natural Gas as supply pressure media Class I, Division 1, Groups C and D; Class II, Division 1, Groups E, F and G; Class I, Division 2, Groups A, B, C and D. Class II, Division 2, Groups E, F and G. Factory Sealed	Approvals are valid when connected through a Shunt Zener Diode Safety Barrier meeting the following parametric requirements: <table border="1"> <tbody> <tr> <td>System Type 1:</td> <td>Single Channel Polarized Rated: 28.5V Max. 300 Ohm Min.</td> </tr> <tr> <td>System Type 2:</td> <td>Dual Channel Polarized Rated 28.5V Max. 300 Ohm Min. and 28V Diode return per channel</td> </tr> <tr> <td>System Type 3:</td> <td>Dual Channel Polarized Rated: 28.5V Max. 300 Ohm Min. and 10V Max. 50 Ohm Min.</td> </tr> </tbody> </table>	System Type 1:	Single Channel Polarized Rated: 28.5V Max. 300 Ohm Min.	System Type 2:	Dual Channel Polarized Rated 28.5V Max. 300 Ohm Min. and 28V Diode return per channel	System Type 3:	Dual Channel Polarized Rated: 28.5V Max. 300 Ohm Min. and 10V Max. 50 Ohm Min.								
System Type 1:	Single Channel Polarized Rated: 28.5V Max. 300 Ohm Min.															
System Type 2:	Dual Channel Polarized Rated 28.5V Max. 300 Ohm Min. and 28V Diode return per channel															
System Type 3:	Dual Channel Polarized Rated: 28.5V Max. 300 Ohm Min. and 10V Max. 50 Ohm Min.															
Explosive Atmospheres Directive (ATEX) Approvals	Air as supply pressure media Ⓢ II 2 GD EEx d IIB + H ₂ , T5 (-20°C to +65°C) Ambient; IP65 Enclosure. 02ATEX1014	Air as supply pressure media Ⓢ II 1 GD Ex ia IIB T4 Ga Ex ia D20 T90°C Da; Ta=-40°C to +80°C IP65 Enclosure. 11ATEX2161X														
	Group IIA gases, including Natural Gas as supply pressure media Ⓢ II 2 GD EEx d IIB, T5 (-20°C to +65°C) Ambient; IP65 Enclosure.	<table border="1"> <thead> <tr> <th colspan="3">Transducer Parameters</th> </tr> </thead> <tbody> <tr> <td>U_{max}¹ = 28 V</td> <td>P_i³ = 0.7 W</td> <td>L_i⁵ = 0</td> </tr> <tr> <td>I_{max}² = 100 mA</td> <td>C_i⁴ = 0/C</td> <td></td> </tr> <tr> <td>¹U_{max} = Max. Voltage</td> <td>³P_i = Max. Power</td> <td>⁵L_i = Inductance</td> </tr> <tr> <td>²I_{max} = Max. Current</td> <td>⁴C_i = Capacitance</td> <td></td> </tr> </tbody> </table>	Transducer Parameters			U _{max} ¹ = 28 V	P _i ³ = 0.7 W	L _i ⁵ = 0	I _{max} ² = 100 mA	C _i ⁴ = 0/C		¹ U _{max} = Max. Voltage	³ P _i = Max. Power	⁵ L _i = Inductance	² I _{max} = Max. Current	⁴ C _i = Capacitance
Transducer Parameters																
U _{max} ¹ = 28 V	P _i ³ = 0.7 W	L _i ⁵ = 0														
I _{max} ² = 100 mA	C _i ⁴ = 0/C															
¹ U _{max} = Max. Voltage	³ P _i = Max. Power	⁵ L _i = Inductance														
² I _{max} = Max. Current	⁴ C _i = Capacitance															
IECEX Approvals		TEXI7850 Ex IIB T4 Ga Ex ia D20 T90°C Da; Ta=-40°C to +80°C IECEX SIR 11.0074X IP65 Enclosure														
		<table border="1"> <thead> <tr> <th colspan="3">Transducer Parameters</th> </tr> </thead> <tbody> <tr> <td>U_{max}¹ = 28 V</td> <td>P_i³ = 0.7 W</td> <td>L_i⁵ = 0</td> </tr> <tr> <td>I_{max}² = 100 mA</td> <td>C_i⁴ = 0</td> <td></td> </tr> <tr> <td>¹U_{max} = Max. Voltage</td> <td>³P_i = Max. Power</td> <td>⁵L_i = Inductance</td> </tr> <tr> <td>²I_{max} = Max. Current</td> <td>⁴C_i = Capacitance</td> <td></td> </tr> </tbody> </table>	Transducer Parameters			U _{max} ¹ = 28 V	P _i ³ = 0.7 W	L _i ⁵ = 0	I _{max} ² = 100 mA	C _i ⁴ = 0		¹ U _{max} = Max. Voltage	³ P _i = Max. Power	⁵ L _i = Inductance	² I _{max} = Max. Current	⁴ C _i = Capacitance
Transducer Parameters																
U _{max} ¹ = 28 V	P _i ³ = 0.7 W	L _i ⁵ = 0														
I _{max} ² = 100 mA	C _i ⁴ = 0															
¹ U _{max} = Max. Voltage	³ P _i = Max. Power	⁵ L _i = Inductance														
² I _{max} = Max. Current	⁴ C _i = Capacitance															

B
Model TXI 7850
 Explosion Proof

Model TXI7850 Moisture Resistant Electro-Pneumatic Transducer

Mounting Kit

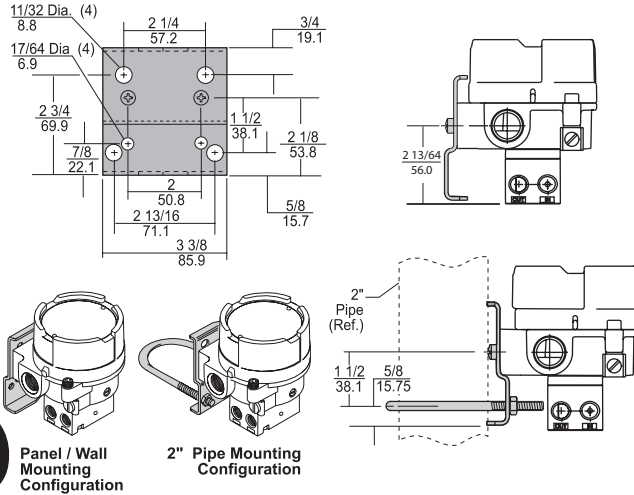

B

Model TXI7850 Transducer Kits & Accessories

Mounting Bracket Kits 19021-1: TCXI7850, TFXI7850 (sold separately)
 19021-2: TEXI7850 (sold separately)

Catalog Information

Catalog Number T
Underwriting Group

Canadian Standard
 ATEX
 Factory Mutual

Temperature Range

-40°F to +160°F

Input

4-20 mA

Output

3-15 psig 01
 3-27 psig 02
 6-30 psig 03
 0-30 psig 04
 0-60 psig 05
 0-120 psig 06
 [0.2-1.0 BAR] 11
 [0.2-1.8 BAR] 12
 [0.4-2.0 BAR] 13
 [0-2.0 BAR] 14
 [0-4.0 BAR] 15
 [0-8.0 BAR] 16
 (20-100 kPa) 21
 (20-180 kPa) 22
 (40-200 kPa) 23
 (0-200 kPa) 24
 (0-400 kPa) 25
 (0-800 kPa) 26

Options

Tapped Exhaust
 Natural Gas media approval, Group D gases ⁴
 (Includes Nipple; TCXI, TEXI, TFXI only) ^{1,2}
 BSPT Thread ³

20 ft cable length⁴
 50 ft cable length⁴
 100 ft cable length⁴

¹ Not approved for Intrinsically Safe.

² Tapped Exhaust option required.

³ Available for ATEX only. NOT available with "N" Option.

⁴ 10 ft cable standard. Longer lengths available. Contact factory for details and availability.

Installation

For installation instructions, refer to the *Fairchild Model TXI7850 Explosion-proof Electro-pneumatic Transducer Installation, Installation Instructions, II-5TXI7850.*

For operation and maintenance instructions, refer to the *Fairchild Model TXI7850/7851 Explosion-proof Electro-pneumatic Transducer Operation and Maintenance Instructions, OM-5TXI7850.*