

Torque Chart

Part Name	Torque Value In Inch-Pounds	Torque Value In Newton-Meters
Solenoid Base Sub-Assembly	175 ± 25	19,8 ± 2,8
Bonnet Screws	144 ± 15	16,3 ± 1,7
Valve Seat	65 ± 125	7,3 ± 1,7

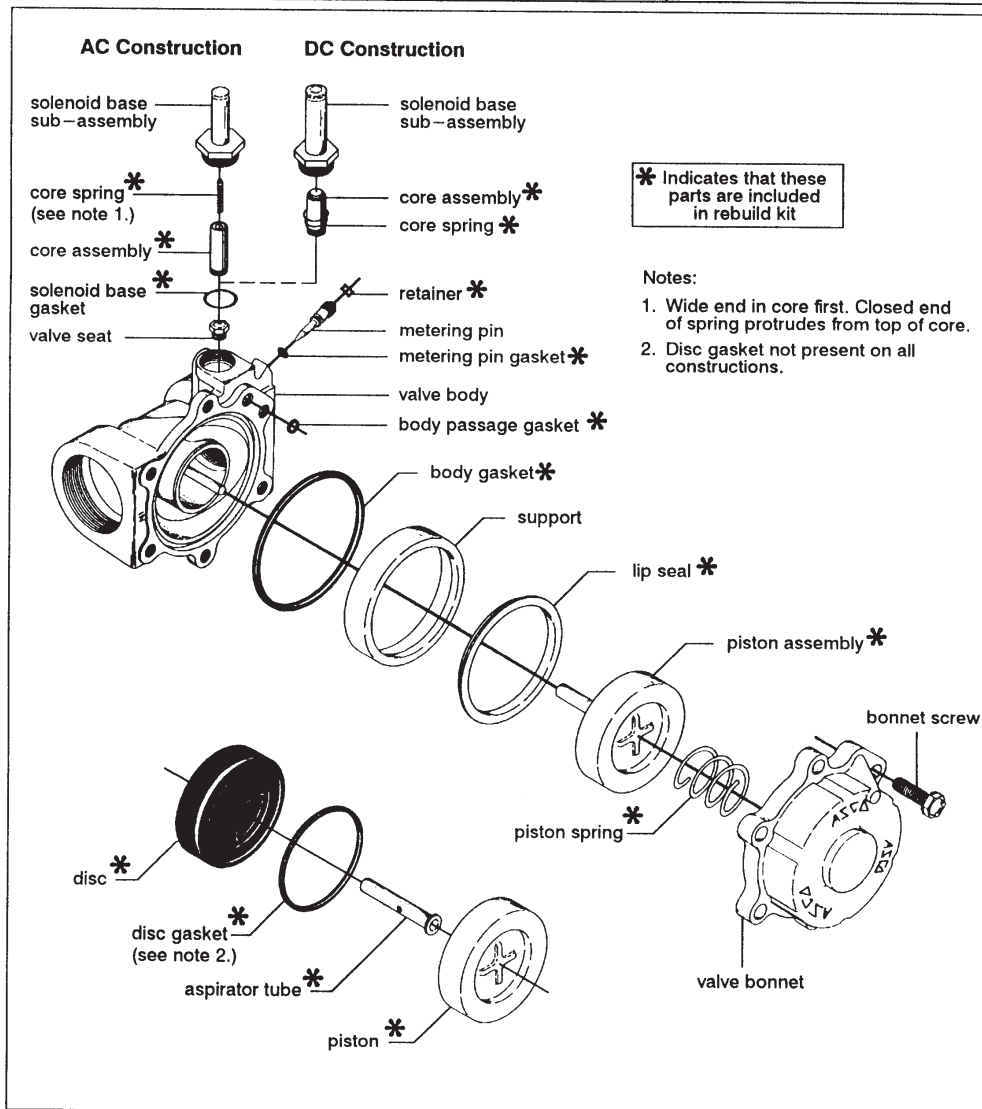

Figure 3. Series 8210 valve without solenoid.

Installation & Maintenance Instructions

2-WAY INTERNAL PILOT-OPERATED SOLENOID VALVES
NORMALLY CLOSED OPERATION
2" OR 2½" NPT

SERIES
8210
8211
Form No.V6296R1

INSTALLATION

Check nameplate for correct catalog number, pressure, voltage, frequency, and service. Never apply incompatible fluids or exceed pressure rating of the valve. Installation and valve maintenance to be performed by qualified personnel.

Future Service Considerations

Provision should be made for performing seat leakage, external leakage, and operational tests on the valve with a nonhazardous, noncombustible fluid after disassembly and reassembly.

Temperature Limitations

For maximum valve ambient and fluid temperatures, refer to chart below. Check catalog number prefix on nameplate to determine the maximum temperatures.

Construction	Catalog Number Prefix	Coil Class	Maximum Ambient Temp. °F	Maximum Fluid Temp. °F
AC	None or FT	F	122	180
	HT	H	140	180
DC	None, FT or HT	F or H	77	150

Positioning

This valve is designed to perform properly when mounted in any position. However, for optimum life and performance, the solenoid should be mounted vertically and upright to reduce the possibility of foreign matter accumulating in the solenoid base sub-assembly area.

Piping

Connect piping or tubing to valve according to markings on valve body. Apply pipe compound sparingly to male pipe threads only. If applied to valve threads, the compound may enter the valve and cause operational difficulty. Avoid pipe strain by properly supporting and aligning piping. When tightening the pipe, do not use valve or solenoid as a lever. Locate wrenches applied to valve body or piping as close as possible to connection point.

IMPORTANT: To protect the solenoid valve, install a strainer or filter, suitable for the service involved, in the inlet side as close to the valve as possible. Clean periodically depending on service conditions. See ASCO Series 8600, 8601 and 8602 for strainers.

MAINTENANCE

▲ WARNING: To prevent the possibility of personal injury or property damage, turn off electrical power, depressurize valve, and vent fluid to a safe area before servicing the valve.

IMPORTANT: See separate solenoid installation and maintenance instructions for information on: Wiring, Solenoid Temperature, Cause of Improper Operation, Coil or Solenoid Replacement.

DESCRIPTION

Series 8210 valves are 2-way normally closed, internal pilot operated solenoid valves designed for general service. These valves are made of rugged forged brass and have an integral adjustable bleed device for controlling the opening and closing speed of the piston. Series 8210 valves are supplied with general purpose, or explosionproof/watertight solenoids.

Series 8211 valves are the same as Series 8210 except they are provided with a metal explosionproof/watertight solenoid enclosure.

OPERATION

Normally Closed: Valve is closed when solenoid is de-energized; open when energized.

IMPORTANT: Minimum operating pressure differential required is 5 psi.

Adjustable Bleed Device

Series 8210 valves have an integral adjustable bleed device for controlling the opening and closing speed of the piston. When valve leaves the factory, the bleed adjusting screw (metering pin) has been preset to provide quick shockless closing for most applications. If faster or slower closing is required, adjust the screw (metering Pin) as follows:

1. Turn metering pin in (clockwise) as far as possible without over tightening. Back out tightening. Back out metering pin (counterclockwise) two complete turns. From this point, adjustments may be made to suit system.
2. Turn metering pin clockwise for slower closing.
3. Turn metering pin counterclockwise for faster closing.

Manual Operation (Optional Feature)

Valves with suffix *MO* in the catalog number are provided with a manual operator which allows manual operation when desired or during an electrical power outage.

To engage manual operator, rotate stem fully clockwise (approximately 180°). Valve will now be in the same position as when the solenoid is energized.

To disengage manual operator, rotate stem fully counterclockwise (approximately 180°) before operating electrically.

▲ CAUTION: Manual operator stem must be fully rotated counterclockwise before electrical operation.

Note: It is not necessary to remove the valve from the pipeline for repairs.

Cleaning

All solenoid valves should be cleaned periodically. The time between cleanings will vary depending on the medium and service conditions. In general, if the voltage to the coil is correct, sluggish valve operation, excessive noise or leakage will indicate that cleaning is required. In the extreme case, faulty valve operation will occur and the valve may fail to open or close. Clean valve strainer or filter when cleaning the valve.

Preventive Maintenance

- Keep the medium flowing through the valve as free from dirt and foreign material as possible.
- While in service, the valve should be operated at least once a month to ensure proper opening and closing.
- Depending on the medium and service conditions, periodic inspection of internal valve parts for damage or excessive wear is recommended. Thoroughly clean all parts. If parts are worn or damaged, install a complete ASCO Rebuild Kit.

Causes of Improper Operation

- **Incorrect Pressure:** Check valve pressure. Pressure to valve must be within range specified on nameplate.
- **Excessive Leakage:** Disassemble valve and clean all parts. If parts are worn or damaged, install a complete ASCO Rebuild Kit.

Valve Disassembly (Refer to Figure 3 on page 4)

1. Disassemble valve in an orderly fashion. Use exploded views for identification and placement of parts.
2. Remove solenoid, see separate instructions.
3. If the valve being serviced has a manual operator, *suffix MO* in the catalog number, refer to section on *Manual Operator Disassembly*.
4. Unscrew solenoid base sub-assembly and remove solenoid base gasket, core assembly with core spring.
5. For normal maintenance, it is not necessary to remove the valve seat. However, if valve seat removal is required, use a 7/16" socket wrench.
6. Dislodge retainer from metering pin passageway and remove metering pin with gasket. Then remove metering pin gasket from metering pin.
7. Remove bonnet screws, valve bonnet, piston spring, piston assembly, support, lip seal, body gasket, and body passage gasket.
8. Remove aspirator tube and disc with disc gasket from piston.
9. All parts are now accessible to clean or replace. If parts are worn or damaged, install a complete ASCO Rebuild kit.

Valve Reassembly

1. Reassemble valve using exploded views for identification and placement of parts.
2. Lubricate the solenoid base gasket, body gasket, body passage gasket, metering pin gasket, and the surface of the piston which contacts the lip seal with DOW CORNING® 200 Fluid lubricant.

3. Lubricate disc and disc gasket with DOW CORNING® 111 Compound lubricant or an equivalent high-grade silicone grease.
4. Position body gasket, body passage gasket, and support in valve body.
5. Install aspirator tube and disc with disc gasket in piston.
6. Position lip seal, flanged end out, onto piston assembly. Install piston assembly with lip seal into support in valve body cavity.
7. Replace piston spring, valve bonnet, and bonnet screws. Torque bonnet screws in a crisscross manner to 144 ± 15 in-lbs [$16,3 \pm 1,7$ Nm].
8. Replace valve seat with a small amount of thread compound on the seat threads. Torque valve seat to 65 ± 15 in-lbs [$7,3 \pm 1,7$ Nm].
9. Install metering pin with metering pin gasket into valve body. Replace retainer and refer to *Adjustable Bleed Device* section for metering pin adjustment.
10. If the valve being serviced has a manual operator, refer to *Manual Operator Reassembly* section.
11. Replace solenoid base gasket, core assembly, core spring, and solenoid base sub-assembly. Torque solenoid base sub-assembly to 175 ± 25 in-lbs [$19,8 \pm 2,8$].
12. Install solenoid, see separate instructions and make electrical hookup.

▲ WARNING: To prevent the possibility of personal injury or property damage, check valve for proper operation before returning to service. Also perform internal seat and external leakage tests with a nonhazardous, noncombustible fluid.

13. Restore line pressure and electrical power supply to valve.
14. After maintenance is completed, operate the valve a few times to be sure of proper operation. A metallic *click* signifies the solenoid is operating.

Manual Operator Disassembly

1. Refer to *Valve Disassembly* section and follow step 1 and 2.
2. For AC construction refer to Figure 1 on page 3; DC construction Figure 2 on page 3.
3. Unscrew solenoid base sub-assembly from manual operator body.
4. Unscrew manual operator body and remove this assembly intact. Remove body gasket from main valve body.
5. Before removing the stem retainer from the manual operator body, note the location of captive spacing washer on the stem/lever sub-assembly. The captive spacing washer will be on the *inside* of the fork on the stem retainer for AC construction and on the *outside* for DC construction. Location of this captive spacing washer is important for reassembly.
6. Remove stem/lever sub-assembly with stem gasket from manual operator body. Remove solenoid base gasket, core assembly with core spring.
7. Refer to *Valve Disassembly* sections, step 5 for further disassembly

Manual Operator Reassembly

Refer to steps 1 through 9 of *Valve Reassembly* then proceed as follows:

1. Position stem gasket on stem/lever sub-assembly.
2. Preassemble manual operator parts as follows: Position core assembly with core spring into manual operator body from the bottom. Install stem/lever sub-assembly into manual operator body. Install stem retainer and be sure the captive spacing washer on the stem/lever sub-assembly is located on the *inside* of the fork on the stem retainer for AC construction and on the *outside* of the fork on the stem retainer for DC construction.
3. Replace body gasket in valve body.
4. Screw manual operator body intact into valve body.

Torque Chart

Part Name	Torque Value In Inch-Pounds	Torque Value In Newton-Meters
Solenoid Base Sub-Assembly	175 ± 25	19,8 ± 2,8
Manual Operator Body		
Valve Seat	65 ± 15	7,3 ± 1,7

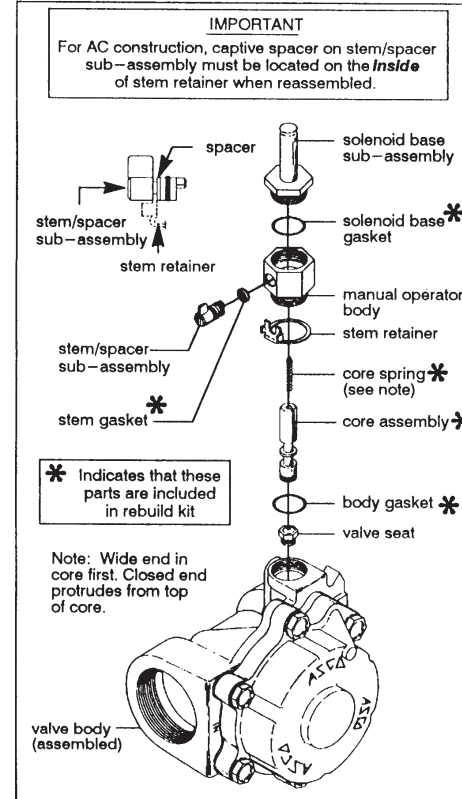

Figure 1. Manual Operator Assembly, AC Construction.

Torque manual operator body to 175 ± 25 in-lbs [$19,8 \pm 2,8$ Nm].

ORDERING INFORMATION FOR

ASCO REBUILD KITS

Parts marked with an asterisk (*) in the exploded view are supplied in Rebuild Kits.

- When Ordering Rebuild Kits for ASCO valves, order the Rebuild Kit number stamped on the valve nameplate. +
- + If the number of the kit is not visible, order by indicating the number of kits required, and the Catalog Number and Serial Number of the valve(s) for which they are intended.

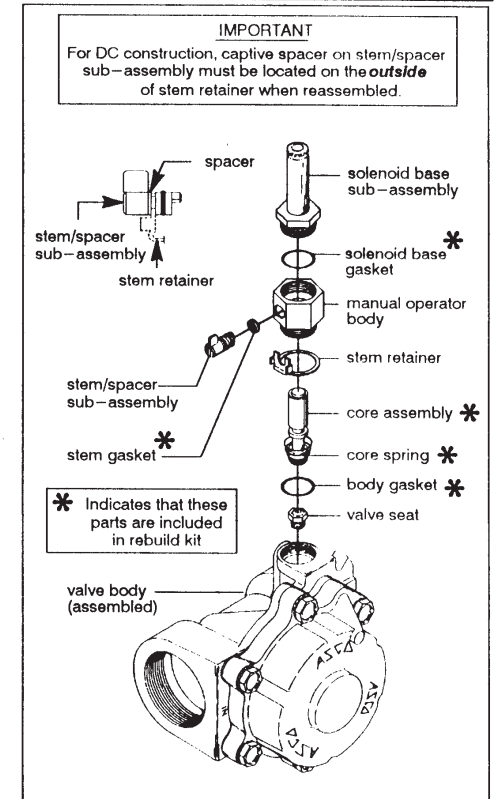

Figure 2. Manual Operator Assembly, DC construction.