

Mounting and accessories

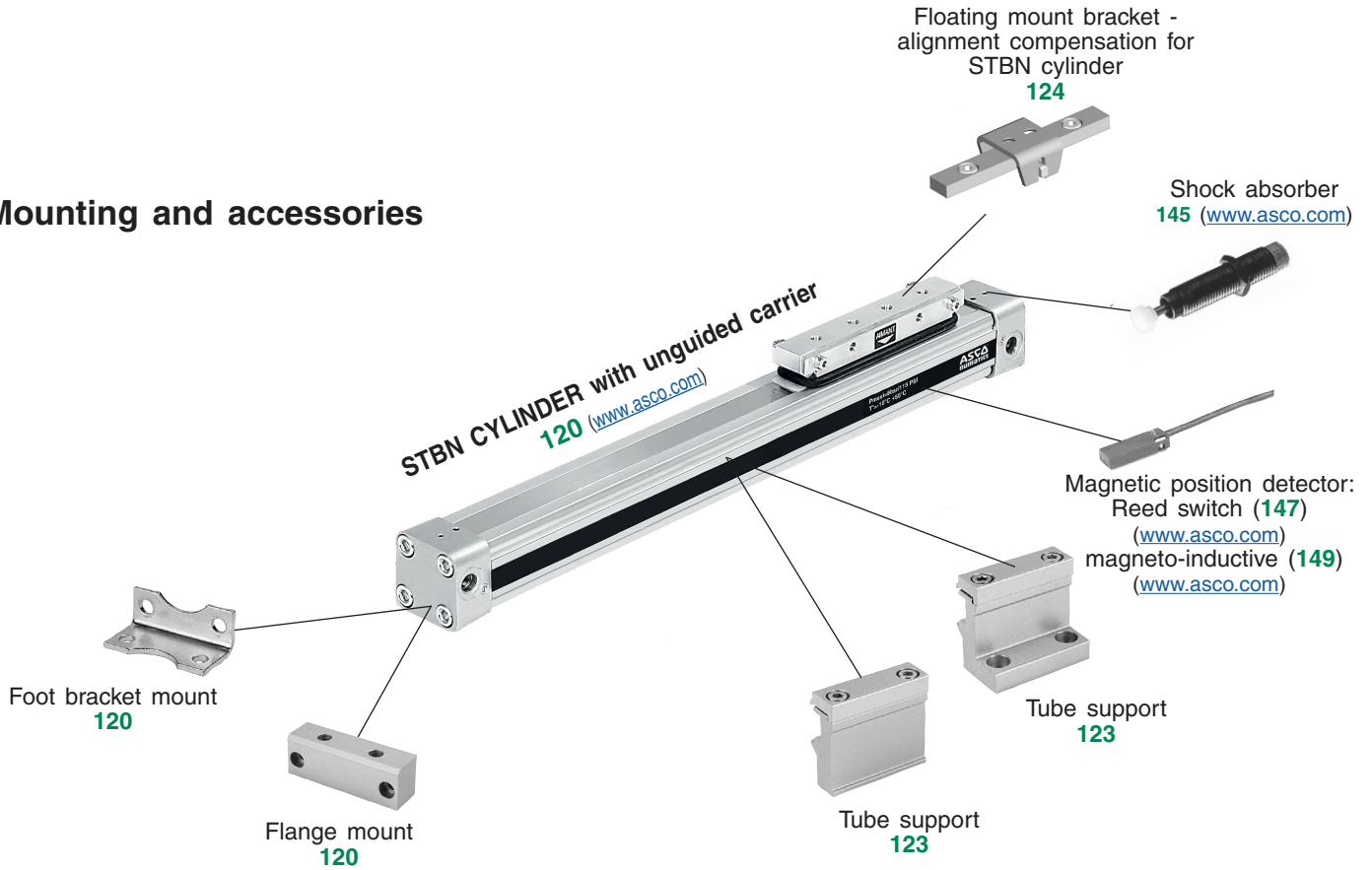

STB cylinder with guided carrier and plain bearing guide
(www.asco.com)



STBB cylinder with guided carrier and cross rollers guide
(www.asco.com)



with passive brake
(www.asco.com)



with active brake
(www.asco.com)

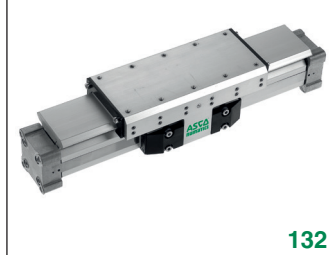

with passive brake
(www.asco.com)



with active brake
(www.asco.com)



00353GB-2017/R01
Availability, design and specifications are subject to change without notice. All rights reserved.

RODLESS BAND CYLINDER WITH UNGUIDED CARRIER

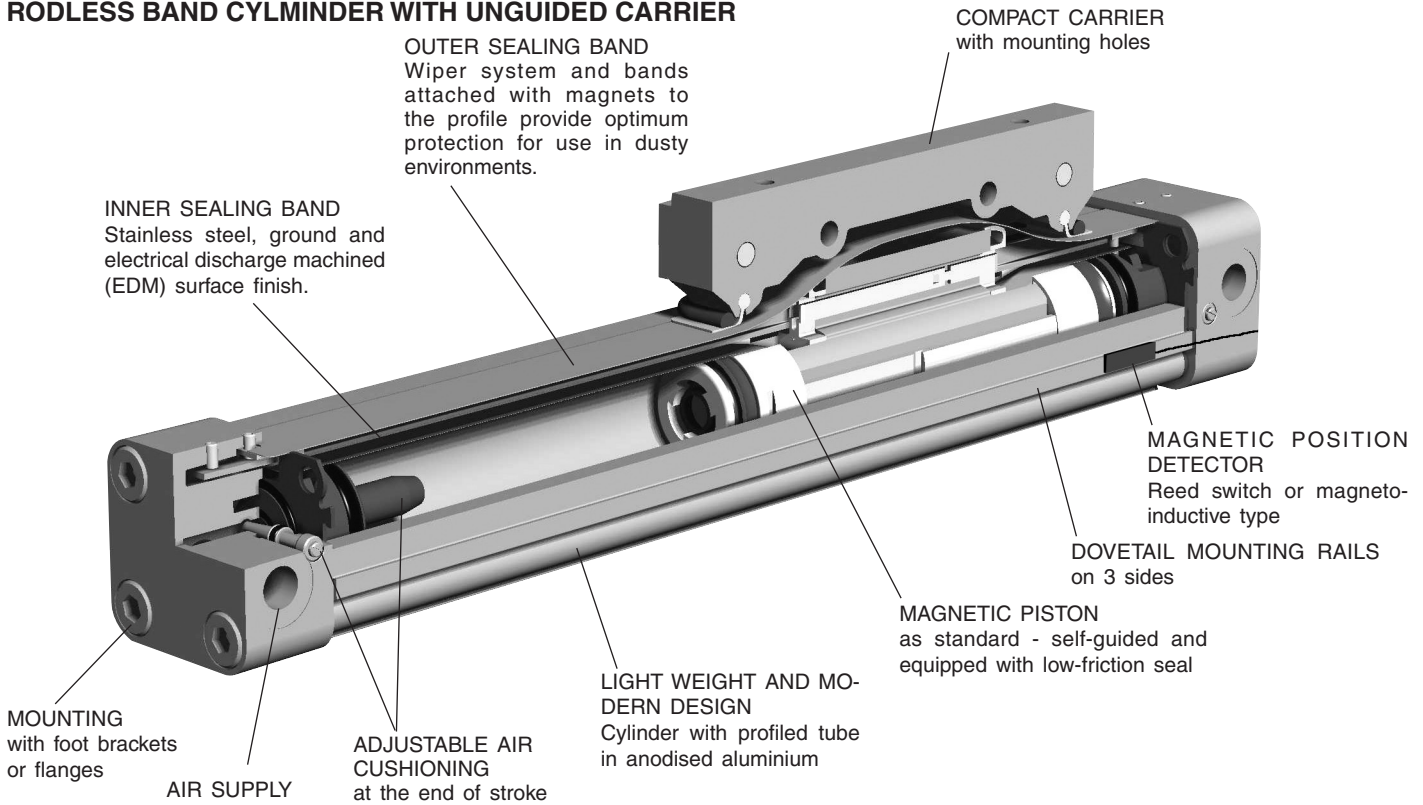

ADVANTAGES

● **COMPACT INSTALLATIONS**

As this cylinder is rodless, installation space is cut by almost half compared to a standard cylinder with a rod.

● **LONG STROKE APPLICATIONS**

The rodless cylinder is perfectly adapted to applications requiring long linear movements, such as handling devices, lifting devices, door opening and closing, etc.

● **QUICK AND EASY ADJUSTMENT**

The carrier can be easily adjusted without having to take it apart. For heavy duty use, we recommend regularly checking the bracket adjustment.

● **LESS MAINTENANCE**

These cylinders operate without lubrication.

● **ADAPTATION POSSIBILITIES**

- **Mounting choices:** Mounting directly on the cylinder ends or with foot brackets
- **Load movement choices:** The load can be mounted directly on the carrier, or with a floating mount bracket, for applications where the cylinder is moving an externally guided and supported load, and when there is a need to compensate for non-parallelism between the cylinder and the load.
- **Air supply:** Front, rear or side.

● **PERFORMANCE AND SECURITY**

Adjustable air cushioning allows for smooth end of stroke and rapid start up. In case of very large and intense movement, the cylinder can be furnished with shock absorbers.

● **SEALING AND PROTECTION FOR USE IN DUSTY ENVIRONMENTS**

Two stainless steel bands provide sealing and protection. They are held in place by a patented band retention method using seals. Wipers on the carrier protect the internal parts from the outside.

● **LARGE RANGE**

The rodless band cylinders are available in Ø 16-25-32-40 50-63 and 80 mm, all strokes are available upon request, and equipped for magnetic detectors.

SPECIFYING THE REFERENCE OF A RODLESS CYLINDER - SERIES 448

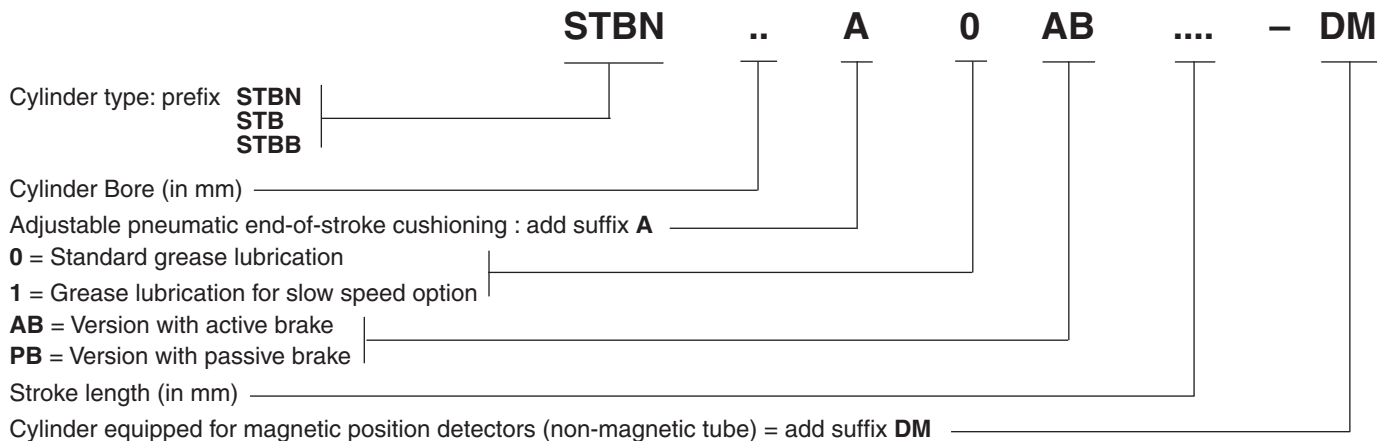

Selecting the appropriate band cylinder is simple. The information you need includes:

- the stroke,
- the force required for moving the load,
- the weight of the load,
- the position of the load (centered on the carrier or elsewhere),
- the final or average velocity.

How to select

Graph (I) represents the theoretical force at various pressures. For the most efficient use of a cylinder, it is recommended to use a load rate of 70 %: the force needed to move the load therefore corresponds to 70% of the theoretical force.

After defining the cylinder diameter, you must determine if the cylinder's internal cushions may be used.

Allowable bending moments

A bending moment will occur if the load is not centered on the carrier (see bending moment data below).

Cushioning capacity

Graph (II) is used to determine the type of cushioning needed. If the intersection point of the final velocity and the load falls below the curves, the internal cushions are adequate. If this is not the case, you must either choose a larger cylinder with greater cushion capacity, or use the shock absorbers which are available as an accessory. If you have determined that the internal cushions would be used near their maximum capacity **and** there is highly intense movement, it would be wise to use the optional shock absorbers.

OTHER ACCESSORIES:

- Tube support brackets: **You must determine if intermediate tube support brackets are required**, depending on the weight of the charge and the stroke. (see chart on tube support sheet).
- Floating carrier bracket: for use when there is a lack of parallelism between the cylinder and a guided and supported load.
- Reed switch or magneto-inductive detectors for position control.

THEORETICAL FORCE AT VARIOUS PRESSURES

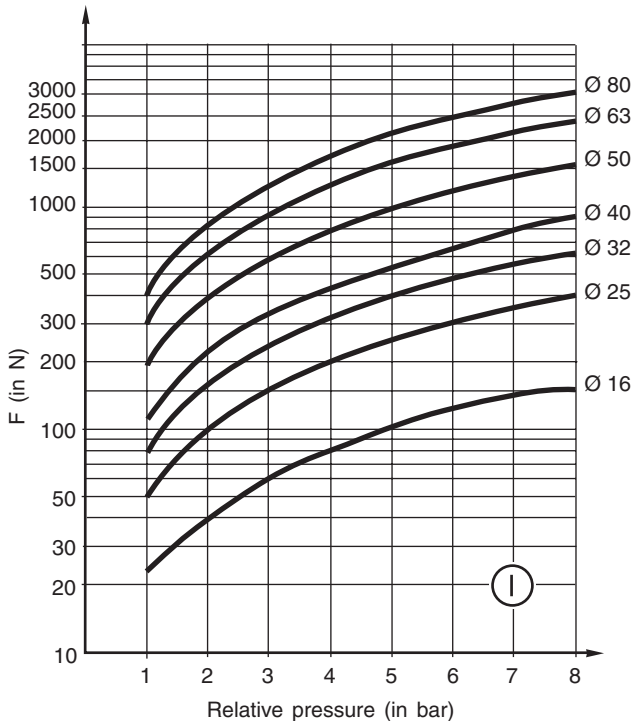

CUSHION DATA

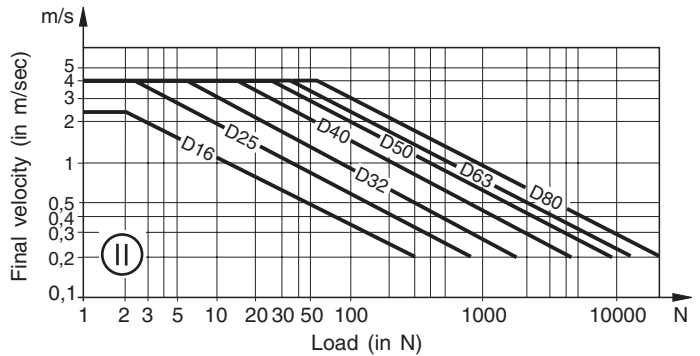

The velocities indicated in graph (II) represent final velocities. To properly determine the inertial forces for cushioning, it is important to know the **final velocity**. If final (or impact) velocity cannot be calculated directly, a reasonable guideline is:

$$\text{Final } V = 1,5 \times \text{average velocity}$$

ALLOWABLE BENDING/TWISTING MOMENTS

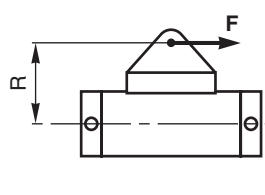
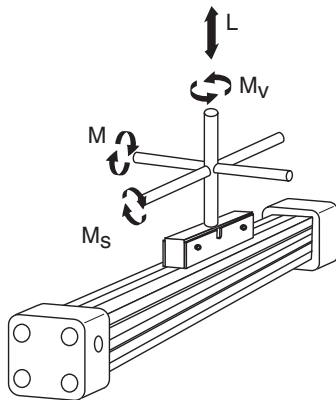

$$M = F \times R$$

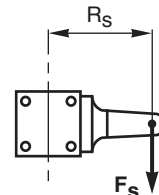

$$M_s = F_s \times R_s$$

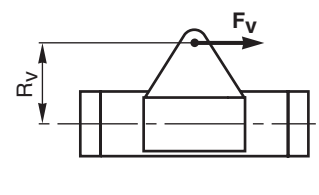

$$M_v = F_v \times R_v$$

Ø Cylinder (mm)	Bending moments (in N.m)			Load (in N)
	M	Ms	Mv	L
16	4	0,3	0,5	120
25	15	1	3	300
32	30	2	5	450
40	60	4	8	750
50	115	7	15	1200
63	200	8	24	1650
80	360	16	48	2400

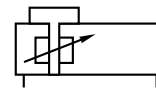

SPECIFICATIONS

FLUID	: air or neutral gas, filtered, unlubricated
PRESSURE	: 8 bar max.
TEMPERATURE	: - 10°C, + 80°C
STROKE min.	: 5 mm (without detectors) : 100 mm (with detectors)
max. standard	: see below (contact us for longer strokes)
MAXIMUM VELOCITY	: 0,2 to 4 m/sec

CONSTRUCTION

Tube	: Anodised aluminium
Ends	: Anodised aluminium
Carrier (piston)	: Anodised aluminium
Piston seals	: Nitrile (NBR)
Piston brackets	: High resistance stamped steel
Bands	: Stainless steel
Magnet	: Placed inside the piston
Covers, wipers	: Plastic
Screws	: Galvanised steel
Cushioning	: with air, adjustable

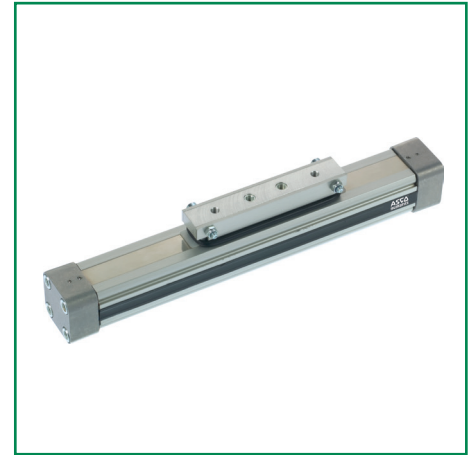

CHOICE OF EQUIPMENT

Ø Cylinder (mm)	CYLINDER EQUIPPED FOR DETECTOR		Max. allowable stroke (mm)	Pipe size	Cushioning length (mm)
	CODE ⁽²⁾	REFERENCE			
16	44850001 ⁽¹⁾	STBN 16 A - 0 ⁽³⁾ - <u> </u> - DM	6000	M5	11
25	44850002 ⁽¹⁾	STBN 25 A - 0 ⁽³⁾ - <u> </u> - DM	6000	G 1/8	17
32	44850003 ⁽¹⁾	STBN 32 A - 0 ⁽³⁾ - <u> </u> - DM	6000	G 1/4	20
40	44850004 ⁽¹⁾	STBN 40 A - 0 ⁽³⁾ - <u> </u> - DM	6000	G 1/4	27
50	44850005 ⁽¹⁾	STBN 50 A - 0 ⁽³⁾ - <u> </u> - DM	6000	G 1/4	30
63	44850006 ⁽¹⁾	STBN 63 A - 0 ⁽³⁾ - <u> </u> - DM	6000	G 3/8	32
80	44850007 ⁽¹⁾	STBN 80 A - 0 ⁽³⁾ - <u> </u> - DM	6000	G 1/2	39

For other strokes, contact us.

- (1) Specify stroke (in mm)
(2) Position detectors are to be ordered separately
(3) 1 for slow speed option

MOUNTINGS

Ø Cylinder (mm)	CODE  Low foot brackets (4)
16	43400493
25	43400494
32	43400495

Ø Cylinder (mm)	CODE  Flanges
40	43400496
50	43400497
63	43400498
80	43400499

Delivered with 2 foot brackets or 2 flanges plus cylinder mounting screws.

The mountings are delivered non assembled.

- (5) Foot brackets for cylinders Ø 25 and 32 allow height adjustment.

ACCESSORIES

- **Floating carrier bracket for alignment compensation** (for guided load movement only)
- **Tube support** (recommended to avoid buckling, depending on the stroke and load)
- [Shock absorbers](#)
- Magnetic detectors: [Reed switch](#) or [magneto-inductive](#) type

OPTION

- Slow speeds from 5 mm/s to 0,2 m/s - code: Ø 16 : **995082** Ø 50 : **995086**
 Ø 25 : **995083** Ø 63 : **995087**
 Ø 32 : **995084** Ø 80 : **995088**
 Ø 40 : **995085**

(When selecting this option, you will have to change the cylinder reference to: STBN .. A **1** ... DM)

DIMENSIONS AND WEIGHTS
BARE CYLINDERS

Ø16 - 32 mm

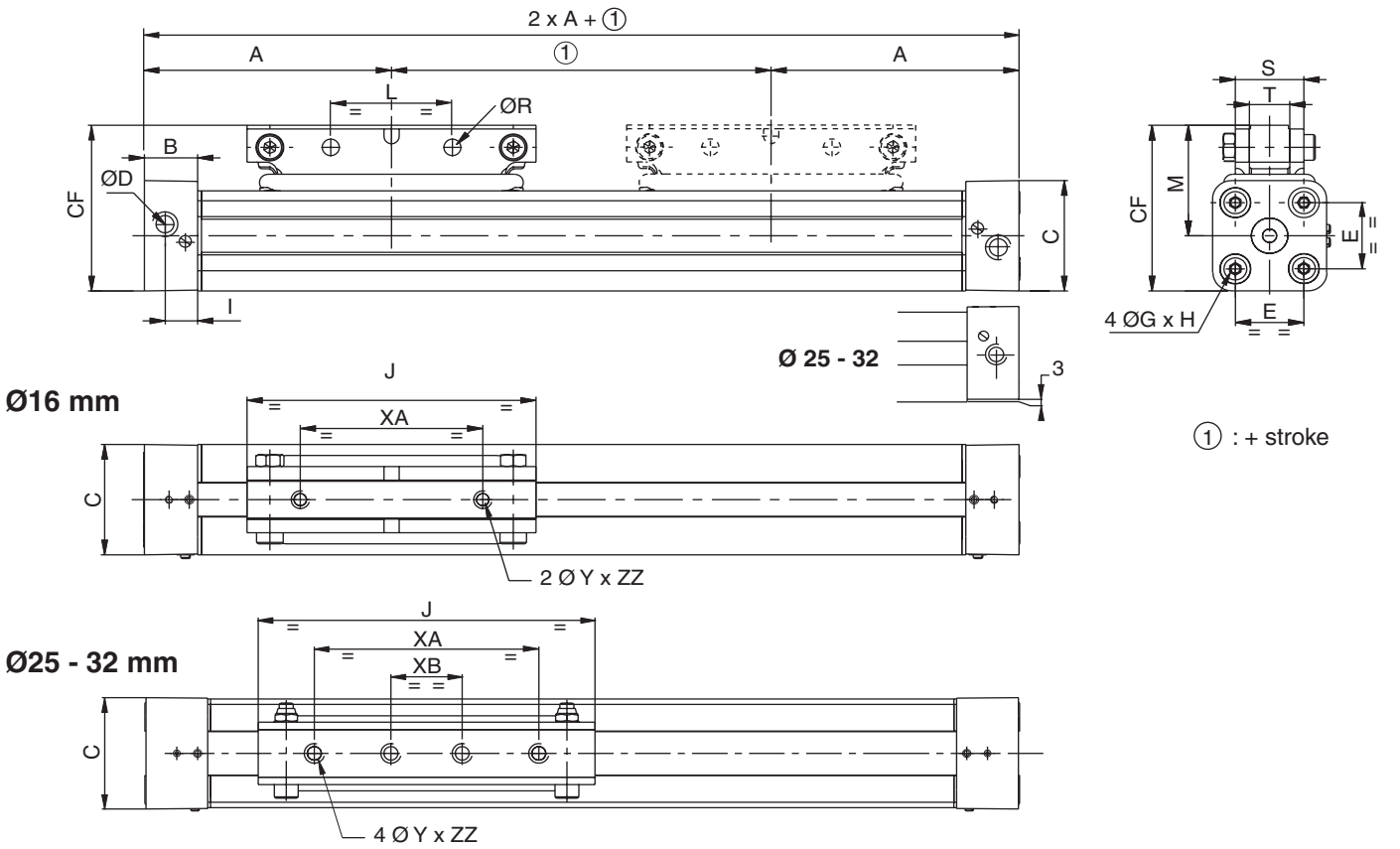

Ø40 - 80 mm

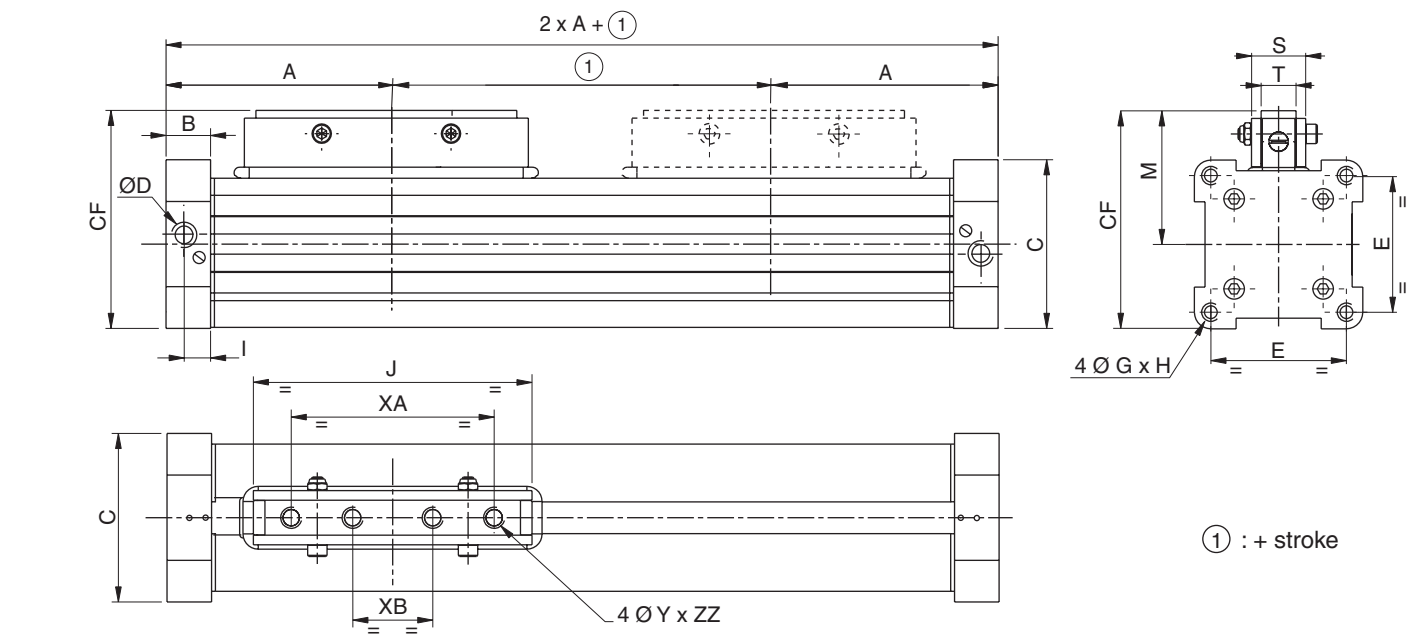

Bore (mm)	DIMENSIONS (mm)																	Weights			
	A	B	C	D	E	G	H	I	J	L	M	R	S	T	Y	CF	XA	XB	ZZ	(1)	(2)
16	65,2	14	30	M5	18	M3	9	8,5	76	16	30	16	18	10,6	M4	45	48	-	8	0,250	0,100
25	100,4	22	41	G1/8	27	M5	15	13	120	-	37	-	23	17,5	M6	58,5	80	25,4	7	0,700	0,197
32	125,2	25,5	52	G1/4	36	M6	15	14	160	-	49	-	27	18	M8	77,5	81,4	25,4	9	1,420	0,354
40	150	28	69	G1/4	54	M6	15	16	150	-	56,8	-	28	18	M8	91,3	107,7	25,4	9	2,130	0,415
50	165	23	87	G1/4	70	M6	15	14	180	-	69	-	28	18	M10	112,5	127	63,5	16	3,590	0,566
63	215	38	106	G3/8	78	M8	21	23,5	220	-	82,8	-	30	19	M10	136,8	152,4	76,2	16	6,640	0,925
80	260	47	132	G1/2	96	M10	25	25	280	-	101	-	32	20	M10	168	180	90	20	12,100	1,262

(1) Weight with 0 mm stroke
(2) Weight to be added per additional 100 mm length

00353GB-2017/R01
Availability, design and specifications are subject to change without notice. All rights reserved.

DIMENSIONS AND WEIGHTS

CYLINDERS WITH MOUNTING BRACKETS

Ø 16 mm

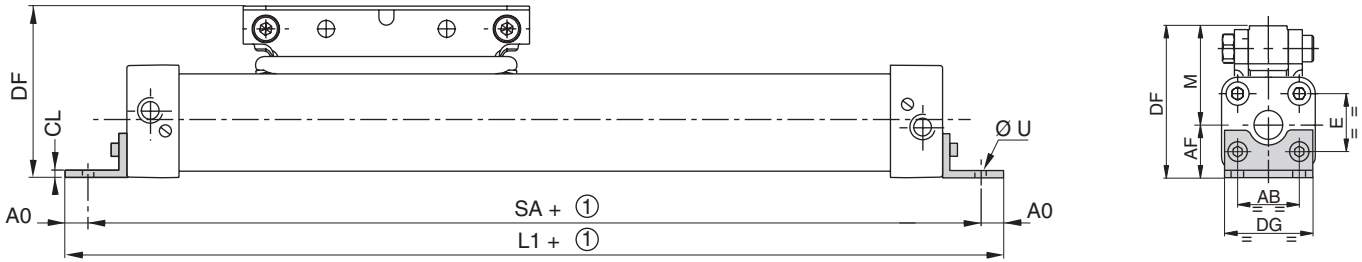

① : + stroke

Ø 25-32 mm

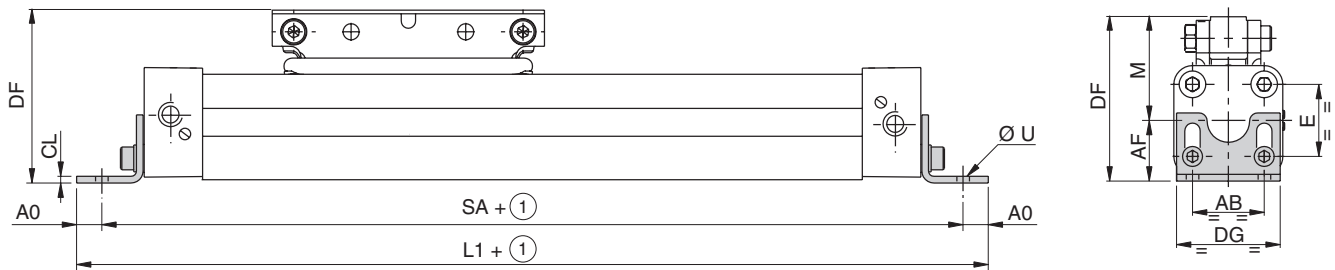

① : + stroke

Ø 40-80 mm

CYLINDERS WITH MOUNTING FLANGES

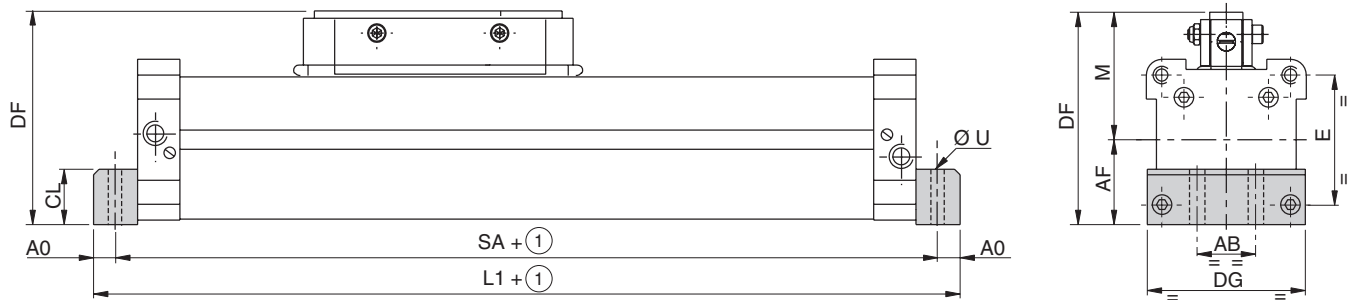

① : + stroke

Bore (mm)	DIMENSIONS (mm)											Weights (kg)	
	AB	AF min max	A0	CL	DF min max	DG	E	L1	M	SA	U	Brackets	Flanges
16	18	15	4	1,6	45	26	18	158,4	30	150,4	3,6	0,017	-
25	27	22,7 32,3	9,5	2,5	59,7 69,3	39	27	250,8	37	231,8	6,6	0,072	-
32	36	32,5 45,2	9,3	3	81,5 94,2	50	36	292,4	49	273,8	7	0,117	-
40	30	35,2	11,3	24	92	68	54	348	56,8	325,4	9	-	0,210
50	31,8	46	16,2	30	115	86	70	378	69	345,6	10	-	0,308
63	48	60,7	15	40	143,5	104	78	490	82,8	460	11	-	0,674
80	60	72	17,5	50	173	130	96	590	101	555	14	-	1,218

For certain strokes and loads, it is necessary to use tube support brackets for intermediate support. The graph below is used to determine the maximum allowable support spacings depending on the load and the number of supports required.

These supports are made of treated light alloy and are designed to fit into the dovetail grooves which run the length of the cylinder tube.

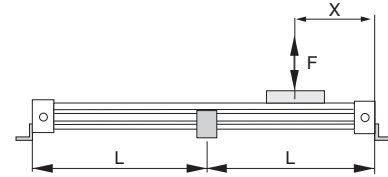
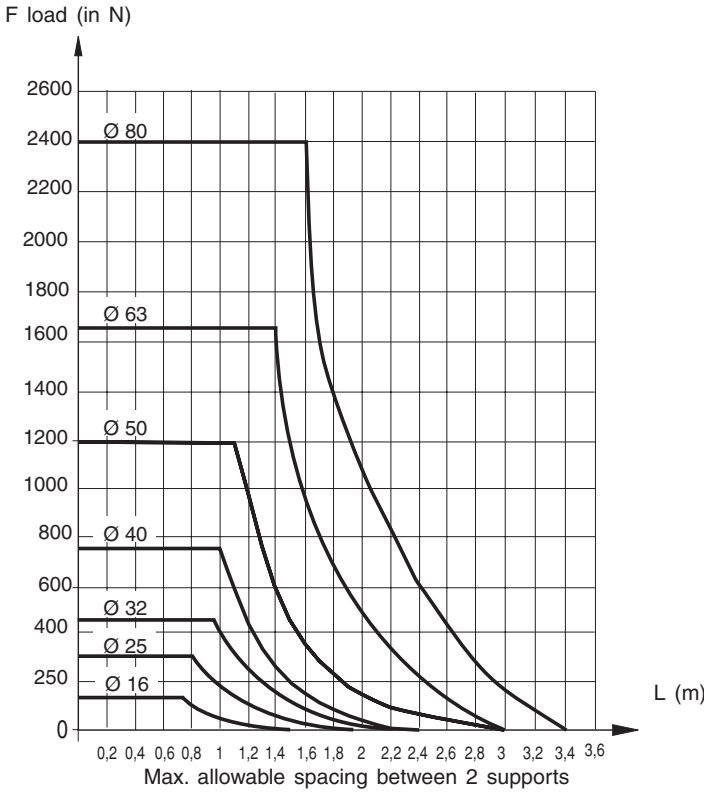

Number of supports needed (n) given that the cylinder is fixed on the ends.

$$n = \left(\frac{\text{Stroke} + 2 X}{L} \right) - 1$$

n = whole number, rounded up.

X = value in mm, mentioned with general cylinder dimensions

L = max. distance defined in the adjacent graph.

CHOICE OF EQUIPMENT

The tube supports must be mounted into the dovetailrails on the cylinder as shown below.

Top mounting

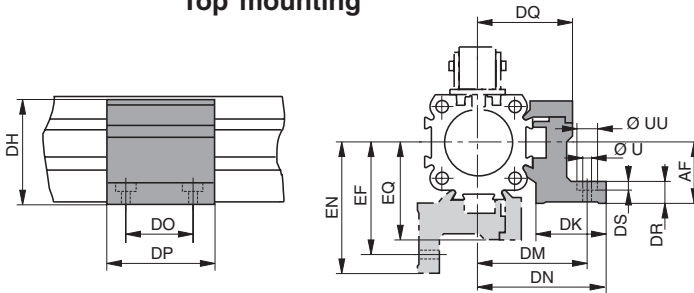

Bore (mm)	CODE	Weights (kg)
16	43400500	0,029
25	43400501	0,130
32	43400502	0,160
40	43400503	0,161
50	43400504	0,189
63	43400505	0,300
80	43400506	0,650

Bottom mounting

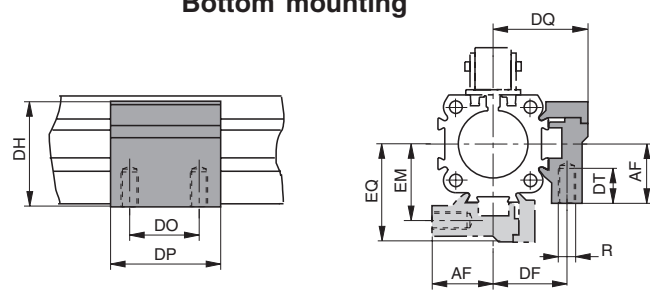

Bore (mm)	CODE	Weights (kg)
16	43400507	0,026
25	43400508	0,061
32	43400509	0,073
40	43400510	0,140
50	43400511	0,169
63	43400512	0,236
80	43400513	0,552

DIMENSIONS

Bore (mm)	DIMENSIONS (mm)																		
	R	U	UU	AF	DF	DH	DK	DM	DN	DO	DP	DQ	DR	DS	DT	EF	EM	EN	EQ
16	M3	3,4	6	15	20	29,2	24	32	36,4	18	30	27	6	3,4	6,5	32	20	36,4	27
25	M5	5,5	10	25	27	41	26	40	47,5	36	50	34,5	11	5,7	10	41,5	28,5	49	36
32	M5	5,5	10	33	33	49	27	46	54,5	36	50	40,5	13	5,7	10	48,5	35,5	57	43
40	M6	7	-	35,2	35	58,2	34	53	60	45	60	45	7,2	-	11	56	38	63	48
50	M6	7	-	46	40	69	34	59	67	45	60	52	8	-	11	64	45	72	57
63	M8	9	-	60,7	47,5	94,7	44	73	83	45	65	63	15,7	-	16	79	53,5	89	69
80	M10	11	-	72	60	111,5	63	97	112	55	80	81	15	-	25	103	66	118	87

For applications where a band cylinder moves a load that is externally guided and supported, a floating carrier bracket is necessary to compensate for non-parallelism and friction losses between the cylinder and the independent guiding member.

This flexible fastening compensates for the following alignment errors:

- Lateral
- Vertical
- Horizontal
- Longitudinal

Alignment compensation

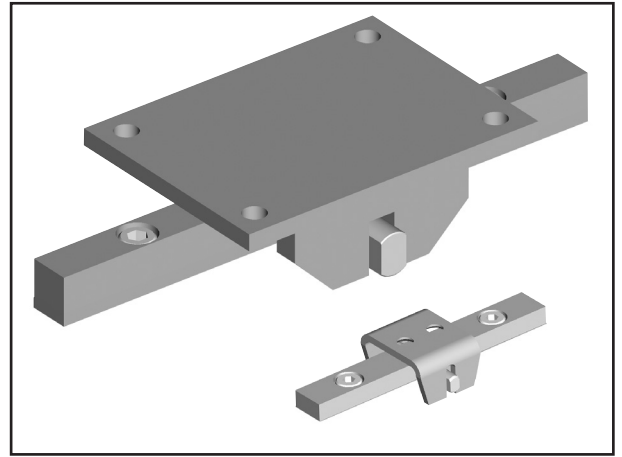
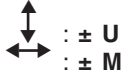

DIMENSIONS AND WEIGHTS

Ø 16 mm

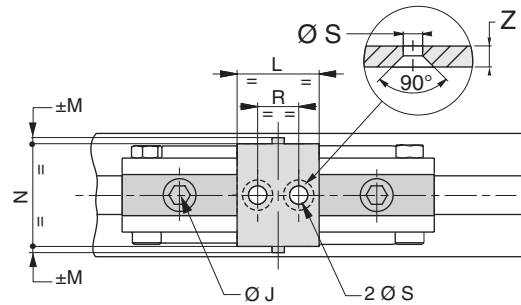
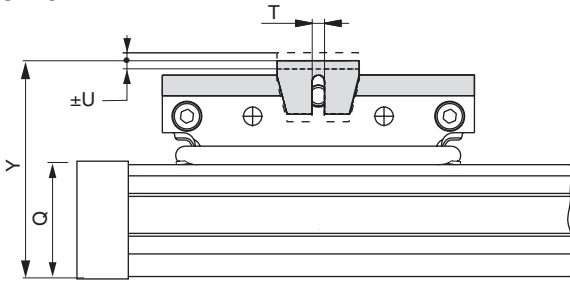

Ø 25 to 63 mm

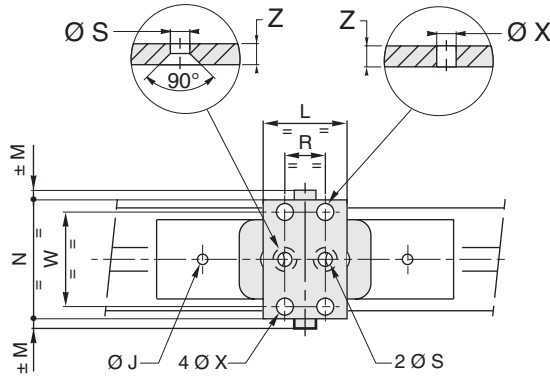
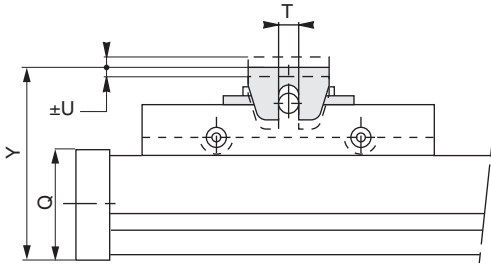

Ø 80 mm

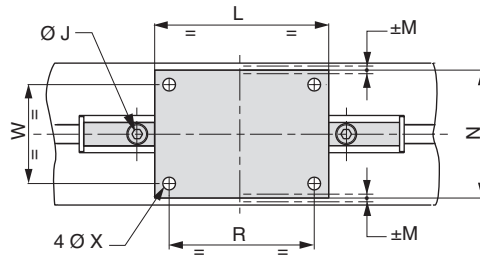
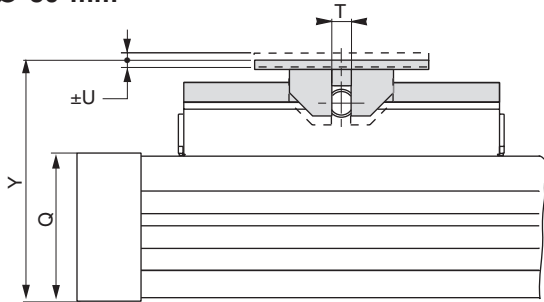

Ø Cyl. (mm)	MOUNT BRACKET CODE	DIMENSIONS (mm)													Weights (kg)
		Ø J	L	± M	N	R	Ø S	T	± U	W	Ø X	Y	Q	Z	
16	43400526	M4	20	1,5	25	10	4,5	3	1,5	-	-	52,5	30	2	0,432
25	43400232	M6	32	3,3	46	15,7	5,6	8	3,8	-	-	71	41	3	0,110
32	43400233	M8	70	4	56	50	7	8	4	-	-	94,5	52	4	0,250
40	43400234	M8	90	7	75	75	-	11	6	55	7	108	69	7	0,540
50	43400235	M10	100	7	82	80	8,6	16	6,4	-	-	139	87	5	0,610
63	43400236	M10	120	12	98	100	-	16	7	70	8,6	156	106	5	0,730
80	43400532	M10	150	4	110	125	-	13	4	85	11	203,2	132	8	1,320

Floating mount bracket mounting screws are supplied.

The fastening screws for the carrier and the load must be secured with LOCTITE 241.

All leaflets are available on: www.asco.com