

Subject to change without notice

VALVE AUTOMATION
SYSTEMS

www.elo-matic.com
EL-O-MATIC[®]

All rights reserved

Nr.:

A 3.308.1

Date:

March '06

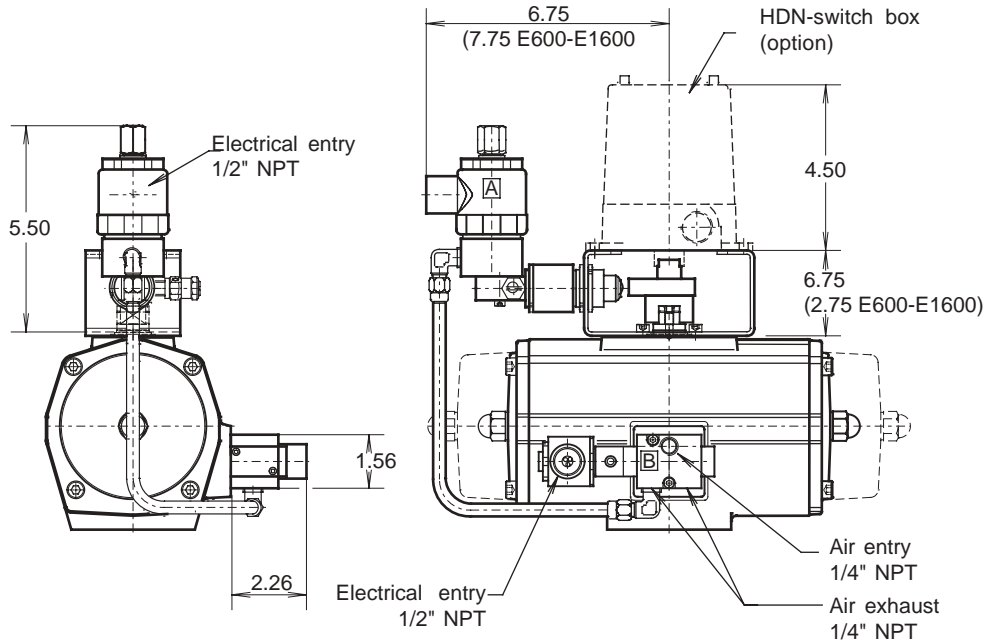

Operating sequence

	Solenoid A	Solenoid B	Valve moves to position
1.	OFF	OFF	CLOSED
2.	ON	ON	FULL OPEN
3.	ON	OFF	DRIBBLE
4.	OFF	OFF	CLOSED

Description:

For use on batching and filling systems where a two stage shut off is required, for instance in the filling sequence: CLOSED - FULL - OPEN - DRIBBLE - CLOSED. The system may be with either double acting or spring return actuators in conjunction with most ¼ turn valves.

The sequence is controlled electrically by two solenoid valves "A" and "B". With both solenoids "ON" the actuator moves full open, as "B" is de-energised movement is to the dribble position and with both solenoids "OFF" the actuator returns to the closed position.

The dribbled position is sensed by a pneumatic valve witch is operated by a cam on the top shaft extension, this is fully adjustable through the 90° stroke. The top mounting bracket has provision for the installation of the "HDN" switch box (option), which may be fitted with a third switch to indicate the dribble position.

The system moves to the "FAIL CLOSE" position on electrical failure. If fail close is required on air only, a spring return actuator should be used and a pressure sensing piloted solenoid valve "A" will be provided.

Specification:

Air pressure : 20 to 120 psi
 Temperature : -4° to 176°F
 Repeatability : 1%
 Other dimensions : see data sheet A 1.103.xxx

Solenoid valves:

Solenoid	Current (at 120VAC/60Hz.)		Power (Watts)
	in rush (A)	holding (A)	
A	.26	.16	12
B	.12	.07	7

Identification:

"DC1" is added to the basic actuator part nr. i.e.. ES200-DC1

Options:

Pneumatic fail safe, explosion proof, various voltages, intrinsically safe etc.

EL-O-MATIC ACTUATOR WITH DRIBBLE CONTROL

DC1