

# TRANSPARENT GAGES QUEST-TEC GLASS-TRAC

Glass-Trac Transparent Gages use clear, see-through glass on both sides so that both the color and the interface of liquids can be viewed. Electric lighted gage illuminators are available for use on Transparent Gages and provide easy viewing of liquid levels in dimly lighted areas. Transparent Gages are made in three pressure series (maximum 3000 psig @ 100°F) and are tapped for ½" or ¾" NPT connections. The standard Glass-Trac level gages are designed for -20°F service.

On Glass-Trac Transparent Close Hook-up Gages with ½" NPT connections, the center-to-center dimension is the same as the overall length on standard gages. On Close Hook-up Gages with ¾" NPT connections the center-to-center dimensions is the same as the overall length on standard gages plus 3/8 ".



Typical Transparent  
Top/Bottom



Typical Transparent  
Close Hook-Up

## MATERIALS

**Body (Liquid Chamber):** Accurately machined from square tubes to provide perfect seating for gage glasses. Glass is recessed for protection. Body materials include 316 stainless steel and carbon steel.

**Cover:** Glass-Trac gage covers are made of carbon steel or 316 stainless steel in all sizes and pressure ratings for higher strength and dependable service. All covers are machined to provide recessed seating protection for the glass.

**Glass:** All standard Glass-Trac Reflex Gages use tempered borosilicate glass in nine standard lengths. Each glass has expertly molded reflecting prisms.

**Gaskets:** High grade non-asbestos is used in gaskets and cushions for Glass-Trac gages. The machined recess in the gage body and cover protects the gasket and cushion as well as the glass.

**Bolts:** Glass-Trac gage bolts are made of alloy steel, ASTM A-193 Grade B7.

**Nuts:** Gage nuts are made of steel, ASTM A-194 Grade 2H.

*(Torque instructions for gage bolts are on the back cover)*

# MODEL CODE BREAKDOWN

## PRESSURE RATINGS & DIMENSIONS

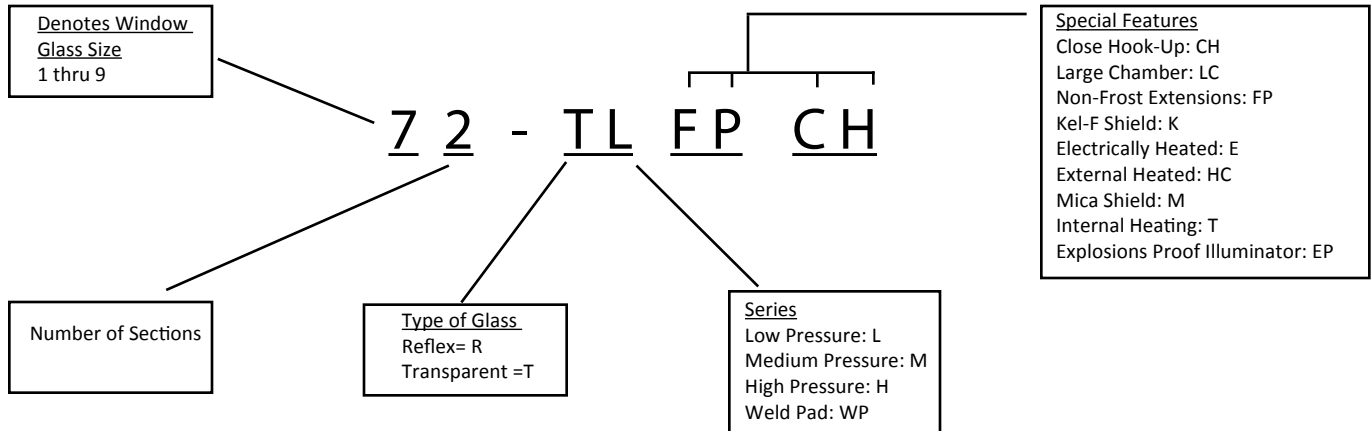

### TRANSPARENT GAGES

SIZE & WEIGHTS											
SIZE NUMBERS			OVER-ALL LENGTH (IN.)			VISIBLE GLASS (IN.) B	GLASS SIZE C	CLOSE HOOK-UP CENTER-TO-CENTER (IN.)		APPROX. WT. (LBS.)	
LOW PRESS.	MID PRESS.	HIGH PRESS.	A (STD)* ½" OR ¾" NPT	A (CH) ½" NPT	A (CH) ¾" NPT			D ½" NPT	D ¾" NPT	LOW PRESS.	MID-HIGH PRESS.
<b>SINGLE-SECTION GAGE</b>											
11TL	11TM	11TH	5.25	8.875	9.25	3.75	3.75	5.25	5.625	10	12
21TL	21TM	21TH	6.25	9.875	10.25	4.75	4.75	6.25	6.625	11	14
31TL	31TM	31TH	7.25	10.875	11.25	5.75	5.75	7.25	7.625	14	17
41TL	41TM	41TH	8.25	11.875	12.25	6.75	6.75	8.25	8.625	16	19
51TL	51TM	51TH	9.375	13	13.375	7.875	7.875	9.375	9.75	17	21
61TL	61TM	61TH	10.625	14.25	14.625	9.125	9.125	10.625	11	19	24
71TL	71TM	71TH	11.75	15.375	15.75	10.25	10.25	11.75	12.125	21	27
81TL	81TM	81TH	13.375	17	17.375	11.875	11.875	13.375	13.75	24	30
91TL	91TM	91TH	14.125	17.75	18.125	12.625	12.625	14.125	14.5	26	32
<b>TWO-SECTION GAGE</b>											
32TL	32TM	32TH	14.5	18.125	18.5	13	5.75	14.5	14.875	27	33
42TL	42TM	42TH	16.5	20.125	20.5	15	6.75	16.5	16.875	32	38
52TL	52TM	52TH	18.75	22.375	22.75	17.25	7.875	18.75	19.125	36	43
62TL	62TM	62TH	21.25	24.875	25.25	19.75	9.125	21.25	21.625	40	49
72TL	72TM	72TH	23.5	27.25	27.5	22	10.125	23.5	23.875	43	54
82TL	82TM	82TH	26.75	30.375	30.75	25.25	11.875	26.75	27.125	50	61
92TL	92TM	92TH	28.25	31.875	32.25	26.75	12.625	28.25	28.625	51	64
<b>THREE-SECTION GAGE</b>											
63TL	63TM	63TH	31.875	35.5	35.875	30.375	9.125	31.875	32.25	59	73
73TL	73TM	73TH	35.25	38.875	39.25	33.75	10.25	35.25	35.875	63	80
83TL	83TM	83TH	40.125	43.75	44.125	38.625	11.875	40.125	40.5	75	92
93TL	93TM	93TH	42.375	46	46.375	40.875	12.625	42.375	42.75	78	97
<b>FOUR-SECTION GAGE</b>											
74TL	74TM	74TH	47	50.875	51	45.5	10.25	47	47.375	85	107
84TL	84TM	84TH	53.5	57.125	57.5	52	11.875	53.5	53.875	100	122
94TL	94TM	94TH	56.5	60.125	60.5	55	12.625	56.5	56.875	104	129
<b>FIVE-SECTION GAGE</b>											
75TL	75TM	75TH	58.25	62.375	62.75	57.25	10.25	58.75	59.125	106	134
85TL	85TM	85TH	66.875	70.5	70.875	65.375	11.875	66.875	67.25	124	152
95TL	95TM	95TH	70.625	74.25	74.625	69.125	12.625	70.625	71	129	161

\*3/4" NPT Tapped High Pressure Gages Add 1-1/2" to 'A' Dimension

# TRANSPARENT GAGE CONNECTIONS

## Transparent Gages -Straight Thru Connections

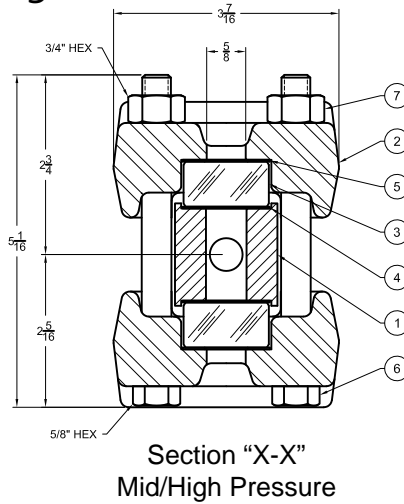
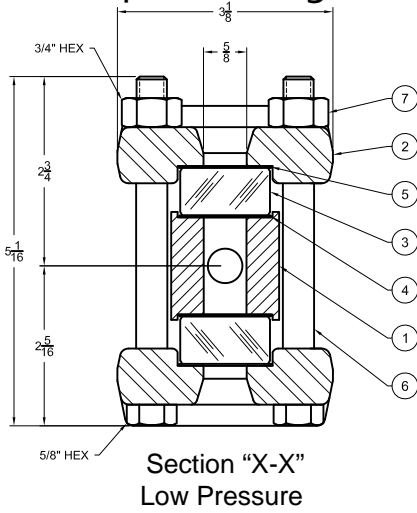

## Transparent Gages -Close Hook-Up Connections

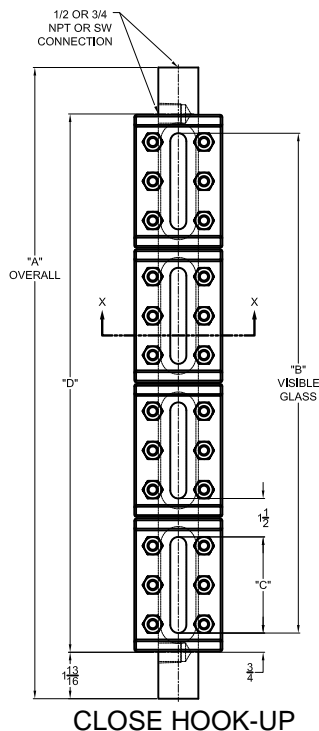
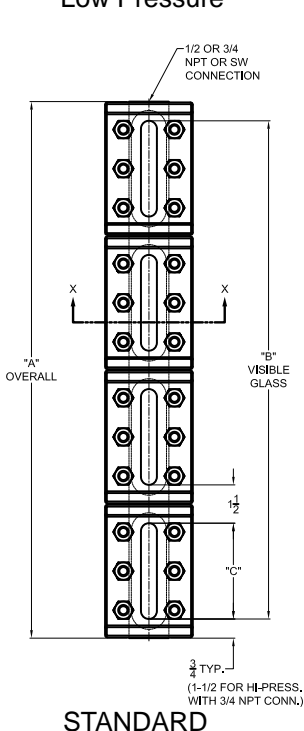
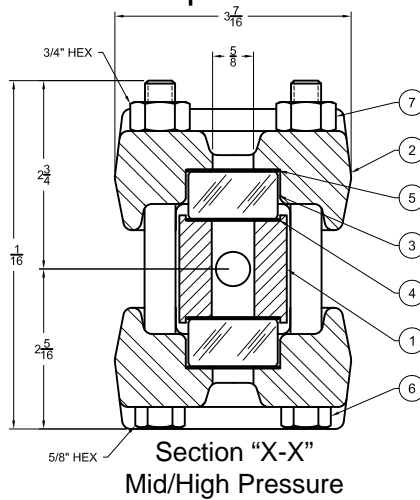
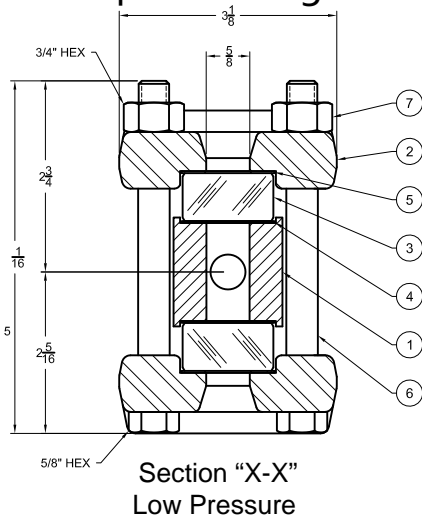

Item No.	Name	Material
1	Chamber	Carbon Steel
2	Cover	Carbon Steel
3	Glass	Tempered
4	Gasket	Non-Asbestos
5	Cushion	Non-Asbestos
6	Bolt	ASTM A193 B7
7	Nut	ASTM A193 B7

Pressure Ratings At °F*							
Low Pressure Gage**							
Glass Size	100°F	200°F	300°F	400°F	500°F	600°F	700°F
1	2000	1935	1870	1790	1660	1480	1260
2	1815	1750	1690	1620	1510	1340	1150
3	1630	1580	1520	1460	1360	1210	1050
4	1440	1390	1340	1290	1200	1060	900
5	1250	1210	1170	1120	1040	920	790
6	1065	1030	995	950	890	790	680
7	875	845	815	785	730	645	550
8	690	665	645	620	575	510	440
9	500	480	465	445	415	370	320
Mid-Pressure Gage**							
Glass Size	100°F	200°F	300°F	400°F	500°F	600°F	700°F
1	2500	2420	2340	2240	2080	1850	1580
2	2315	2250	2170	2090	1940	1720	1470
3	2130	2060	1990	1910	1770	1575	1340
4	1940	1875	1810	1740	1620	1435	1230
5	1750	1690	1630	1570	1460	1295	1100
6	1565	1510	1460	1400	1305	1160	990
7	1375	1330	1280	1230	1145	1015	870
8	1190	1150	1110	1065	990	880	750
9	1000	970	935	985	835	740	630
High Pressure Gage**							
Glass Size	100°F	200°F	300°F	400°F	500°F	600°F	700°F
ALL	4000	2920	2850	2780	2600	2310	1890

\*\*Gages for service up to 800°F are available. Consult QTS for applications and ratings

# INSTALLATION: STANDARD GAGES (TOP/BOTTOM CONNECTION)

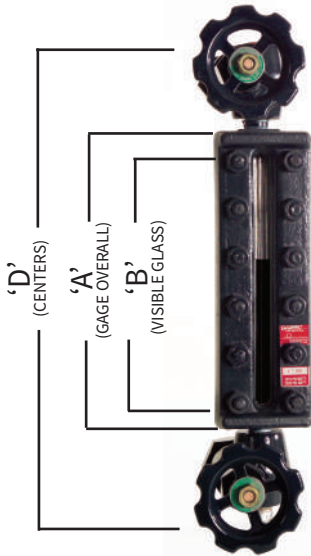

**Note: Use the following constants for other level gages.**

1. Low pressure (series L) large chamber, add 1" to dimensions "A" and "D"
2. Low pressure (series L), mid pressure (series M) externally heated/ cooled, add 2-1/4" to above "D" dimensions
3. For valve Types 3, 5, or 7 add 7/8" to Column "D" to obtain minimum centers
4. For High Pressure (series H) with 3/4" NPT, add 1 1/2" to dimensions "A" and "D"
5. For a 1/2" NPT Female Spherical Gage Connection add 1-7/8"

SIZE NO.		A GAGE OVERALL	B VISIBLE GLASS	C VISIBLE GLASS	D* MINIMUM VALVE CENTER-TO-CENTER WITH GAGE CONNECTION							
					FOR GAGES TAPPED 1/2" NPT				FOR GAGES TAPPED 3/4" NPT			
					** 1/2"- NPT FEMALE SCREWED CAT. 1S, 2S, 4S	** 1/2"- NPT FEMALE SCREWED CAT. 1U, 2U, 4U	1/2"-NPT MALE UNION FIG. VIII	1/2"-NPT MALE SPHERICAL FIG. XIV	**3/4"-NPT FEMALE SCREWED CAT. 1S, 2S, 4S	3/4"-NPT FEMALE SCREWED CAT. 1U, 2U, 4U	3/4"-NPT MALE UNION FIG. XI	3/4"-NPT MALE SPHERICAL FIG. X
1	1	5 1/4	3 3/4	3 3/4	8 1/2	11	11 5/8	12 3/4	8 3/4	11 5/8	11 1/2	12 5/8
2	1	6 1/4	4 3/4	4 3/4	9 1/2	12	12 5/8	13 3/4	9 3/4	12 5/8	12 1/2	13 5/8
3	1	7 1/4	5 3/4	5 3/4	10 1/2	13	13 5/8	14 3/4	10 3/4	13 5/8	13 1/2	14 5/8
4	1	8 1/4	6 3/4	6 3/4	11 1/2	14	14 5/8	15 3/4	11 3/4	14 5/8	14 1/2	15 5/8
5	1	9 3/8	7 7/8	7 7/8	12 5/8	15 1/8	15 3/4	16 7/8	12 7/8	15 3/4	15 5/8	16 3/4
6	1	10 5/8	9 1/8	9 1/8	13 7/8	16 3/8	17	18 1/8	14 1/8	17	16 7/8	18
7	1	11 3/4	10 1/4	10 1/4	15	17 1/2	18 1/8	19 1/4	15 1/4	18 1/8	18	19 1/8
8	1	13 3/8	11 7/8	11 7/8	16 5/8	19 1/8	19 3/4	20 7/8	16 7/8	19 3/4	19 5/8	20 3/4
9	1	14 1/8	12 5/8	12 5/8	17 3/8	19 7/8	20 1/2	21 5/8	17 5/8	20 1/2	20 3/8	21 1/2
3	2	14 1/2	13	5 3/4	17 3/4	20 1/4	20 7/8	22	18	20 7/8	20 3/4	21 7/8
4	2	16 1/2	15	6 3/4	19 3/4	22 1/4	22 7/8	24	20	22 7/8	22 3/4	23 7/8
5	2	18 3/4	17 1/4	7 7/8	22	24 1/2	25 1/8	26 1/4	22 1/4	25 1/8	25	26 1/8
6	2	21 1/4	19 3/4	9 1/8	24 1/2	27	27 5/8	28 3/4	24 3/4	27 5/8	27 1/2	28 5/8
7	2	23 1/2	22	10 1/4	26 3/4	29 1/4	29 7/8	31	27	29 7/8	29 3/4	30 7/8
8	2	26 3/4	25 1/4	11 7/8	30	32 1/2	33 1/8	34 1/4	30 1/4	33 1/8	33	34 1/8
9	2	28 1/4	26 3/4	12 5/8	31 1/2	34	34 5/8	35 3/4	31 3/4	34 5/8	34 1/2	35 5/8
6	3	31 7/8	30 3/8	9 1/8	35 1/8	37 5/8	38 1/4	39 3/8	35 5/8	38 1/4	38 1/8	39 1/4
7	3	35 1/4	33 3/4	10 1/4	38 1/2	41	41 5/8	42 3/4	38 3/4	41 5/8	41 1/2	42 5/8
8	3	40 1/8	38 5/8	11 7/8	43 3/8	45 7/8	46 1/2	47 5/8	43 5/8	46 1/2	46 3/8	47 1/2
9	3	42 3/8	40 7/8	12 5/8	45 5/8	48 1/8	48 3/4	49 7/8	45 7/8	48 3/4	48 5/8	49 3/4
7	4	47	45 1/2	10 1/4	50 1/4	52 3/4	53 3/8	54 1/2	50 1/2	53 5/8	53 1/4	54 3/8
8	4	53 1/2	52	11 7/8	56 3/4	59 1/4	59 7/8	61	57	59 7/8	59 3/4	60 7/8
9	4	56 1/2	55	12 5/8	59 3/4	62 1/4	62 7/8	64	60	62 7/8	62 3/4	63 7/8
7	5	58 3/4	57 1/4	10 1/4	62	64 1/2	65 1/8	66 1/4	62 1/4	65 1/8	65	66 1/8
8	5	66 7/8	65 3/8	11 7/8	70 1/8	72 5/8	73 1/4	74 3/8	70 3/8	73 1/4	73 1/8	74 1/4
9	5	70 5/8	69 1/8	12 5/8	73 7/8	76 3/8	77	78 1/8	74 1/8	77	76 7/8	78
8	6	80 1/4	78 3/4	11 7/8	83 1/2	86	86 5/8	87 3/4	83 3/4	86 5/8	86 1/2	87 5/8
9	6	84 3/4	83 1/4	12 5/8	88	90 1/2	91 1/8	92 1/4	88 1/4	91 1/8	91	92 1/8
8	7	93 5/8	92 1/8	11 7/8	96 7/8	99 3/8	100	101 1/8	97 1/8	100	99 7/8	101
9	7	98 7/8	97 3/8	12 5/8	102 1/8	104 5/8	105 1/4	106 3/8	102 3/8	105 1/4	105 1/8	106 1/4
8	8	107	105 1/2	11 7/8	110 1/4	112 3/4	113 3/8	114 1/2	110 1/2	113 3/8	113 1/4	114 3/8
9	8	113	111 1/2	12 5/8	116 1/4	118 3/4	119 3/8	120 1/2	116 1/2	119 3/8	119 1/4	120 3/8
8	9	120 3/8	118 7/8	11 7/8	123 5/8	126 1/8	126 3/4	127 7/8	123 7/8	126 3/4	126 5/8	127 3/4
9	9	127 1/8	125 5/8	12 5/8	130 3/8	132 7/8	133 1/2	134 5/8	130 5/8	133 1/2	133 3/8	134 1/2

\*Dimensions in column "D" apply to low-pressure (series L), mid-pressure (series M), 1/2" NPT high-pressure (series H), frost free (all series), and internally heated/cooled reflex and transparent level gages tapped 1/2" NPT or 3/4" NPT. For installation dimensions on other level gages see footnote.

\*\*These dimensions use close pipe nipples. For short 1/2" nipple add 3/4", for short 3/4" nipple add 1-1/4"

# INSTALLATION: CLOSE HOOK-UP GAGES (SIDE/SIDE CONNECTED GAGE CONNECTIONS)

SIZE NO.	MINIMUM CENTER-TO-CENTER TANK CONNECTIONS					
	STRAIGHT-THRU 1/2" VALVE 3/4"		OFFSET VALVE HANDLES 1/2" INSIDE 3/4"		OFFSET VALVE HANDLES 1/2" OUTSIDE 3/4"	
11	5 1/4"	5 5/8"	3 1/2"	3 7/8"	7"	7 3/8"
21	6 1/4"	6 5/8"	4 1/2"	4 7/8"	8"	8 3/8"
31	7 1/4"	7 5/8"	5 1/2"	5 7/8"	9"	9 3/8"
41	8 1/4"	8 5/8"	6 1/2"	6 7/8"	10"	10 3/8"
51	9 3/8"	9 3/4"	7 5/8"	8"	11 1/8"	11 1/2"
61	10 5/8"	11"	8 7/8"	9 1/4"	12 3/8"	12 3/4"
71	11 3/4"	12 1/8"	10"	10 3/8"	13 1/2"	13 7/8"
81	13 3/8"	13 3/4"	11 5/8"	12"	15 1/8"	15 1/2"
91	14 1/8"	14 1/2"	12 3/8"	12 3/4"	15 7/8"	16 1/4"
32	14 1/2"	14 7/8"	12 3/4"	13 1/8"	16 1/4"	16 5/8"
42	16 1/2"	16 7/8"	14 3/4"	15 1/8"	18 1/4"	18 5/8"
52	18 3/4"	19 1/8"	17"	17 3/8"	20 1/2"	20 7/8"
62	21 1/4"	21 5/8"	19 1/2"	19 7/8"	23"	23 3/8"
72	23 1/2"	23 7/8"	21 3/4"	22 1/8"	25 1/4"	25 5/8"
82	26 3/4"	27 1/8"	25"	25 3/8"	28 1/2"	28 7/8"
92	28 1/4"	28 5/8"	26 1/2"	26 7/8"	30"	30 3/8"
63	31 7/8"	32 1/4"	30 1/8"	30 1/2"	33 5/8"	34"
73	35 1/4"	35 5/8"	33 1/2"	33 7/8"	37"	37 3/8"
83	40 1/8"	40 1/2"	38 3/8"	38 3/4"	41 7/8"	42 1/4"
93	42 3/8"	42 3/4"	40 5/8"	41"	44 1/8"	44 1/2"
74	47"	47 3/8"	45 1/4"	45 5/8"	48 3/4"	49 1/8"
84	53 1/2"	53 7/8"	51 3/4"	52 1/8"	55 1/4"	55 5/8"
94	56 1/2"	56 7/8"	54 3/4"	55 1/8"	58 1/4"	58 5/8"
75	58 3/4"	59 1/8"	57"	57 3/8"	60 1/2"	60 7/8"
85	66 7/8"	67 1/4"	65 1/8"	65 1/2"	68 5/8"	69"
95	70 5/8"	71"	68 7/8"	69 1/8"	72 3/8"	72 3/4"
86	80 1/4"	80 5/8"	78 1/2"	78 7/8"	82"	82 3/8"
96	84 3/4"	85 1/8"	83"	83 3/8"	86 1/2"	86 7/8"
87	93 5/8"	94"	91 7/8"	92 1/4"	95 3/8"	95 3/4"
97	98 7/8"	99 1/4"	97 1/8"	97 1/2"	100 5/8"	101"
88	107"	107 3/8"	105 1/4"	105 5/8"	108 3/4"	109 1/8"
98	113"	113 3/8"	111 1/4"	111 5/8"	114 3/4"	115 1/8"
89	120 3/8"	120 3/4"	118 5/8"	119"	122 1/8"	122 1/2"
99	127 1/8"	127 1/2"	125 3/8"	125 3/4"	128 7/8"	129 1/4"