

Data sheet

(Product Discontinued)

Sheet No.: A5.102 Rev. B

Date: February 2012

ELECTRIC ACTUATOR - TECHNICAL DATA

		ELS-18	ELS-25	EL-35	EL-55	EL-100	EL-150	EL-200	EL-350	EL-500	EL-800	EL-1200	EL-1600	EL-2500
Torque (Nm)	break	18	25	35	55	100	150	200	350	500	800	1200	1600	2500
	run	14	20	12.2	20	35	53	70	123	175	280	420	560	875
Torque (in.lb)	break	160	221	310	487	885	1.328	1.77	3.098	4.425	7.081	10.621	14.16	22.125
	run	124	177	108	177	310	465	620	1.084	1.548	2.478	3.717	4.956	7.744
Op. Time (S)	50 Hz	6.5	9.5	6	6	7.5	9	13.5	22	25.5	25.5	25.5	25.5	28
	60 Hz	5.5	7.5	5	5	6	7.5	11.5	18	21.5	21.5	21.5	21.5	22.5
	24VDC	-	-	-	5	6.5	8	12	20	23	-	-	-	-
Current (A) 120/1/60	break	0.55	0.6	1.1	-	2.9	2.9	2.9	2.9	2.9	4.5	14	14	38
	run	0.45	0.5	0.6	-	2.1	2.1	2.1	2.1	2.1	2.8	5.8	5.8	10.5
220/1/50	break	0.1	0.3	-	0.6	1.7	1.7	1.7	1.7	1.7	2.3	6	6	17
	run	0.1	0.27	-	0.5	1.1	1.1	1.1	1.1	1.1	1.8	2.5	2.5	5.8
380/3/50	break	-	-	-	0.4	0.7	0.7	0.7	0.7	0.7	0.9	2.8	2.8	5.5
	run	-	-	-	0.2	0.4	0.4	0.4	0.4	0.4	0.54	0.9	0.9	1.2
460/3/60	break	-	-	-	0.37	0.63	0.63	0.63	0.63	0.63	0.87	1.1	1.1	2
	run	-	-	-	0.18	0.45	0.45	0.45	0.45	0.45	0.57	0.72	0.72	1.6
24 VDC	break	0.8	0.51	-	5	8	8	8	8	8	-	-	-	-
	run	0.15	0.1	-	1.9	4.9	4.9	4.9	4.9	4.9	-	-	-	-
Power consump. (W)	120/1/60	45	25	100	-	225	225	225	225	225	315	535	535	720
	220/1/50	40	65	-	72	200	200	200	200	200	305	450	450	792
	380/3/50	-	-	-	80	145	145	145	145	145	165	220	220	560
	460/3/60	-	-	-	77	180	180	180	180	180	200	266	266	600
	24VDC	4.8	2.4	-	45	118	118	118	118	118	118	-	-	-
Power factor (cos Phi)	120/1/60	-	-	0.87	0.87	0.98	0.98	0.98	0.98	0.98	0.93	0.83	0.83	0.74
	220/1/50	0.82	0.82	-	0.91	0.82	0.82	0.82	0.82	0.82	0.77	0.92	0.92	0.5
	380/3/50	-	-	-	0.54	0.51	0.51	0.51	0.51	0.51	0.47	0.55	0.55	0.67
	460/3/60	-	-	-	0.54	0.5	0.5	0.5	0.5	0.5	0.44	0.53	0.53	0.6
Motor speed (RPM)	50 Hz	1878	1620	1450	1450	1425	1425	1425	1425	1425	1450	1450	1450	1450
	60 Hz	2328	2040	1725	1725	1725	1725	1725	1725	1725	1725	1725	1725	1725
	24VDC/AC	3230	4210	-	1600	1600	1600	1600	1600	1600	-	-	-	-
Overall gear ratio		849/1	1070/1	1250/1	1250/1	700/1	840/1	1316/1	2106/1	2480/1	2480/1	3100/1	3100/1	2600/1
Capacitor (µF/V)	120/1/60	6.8/250	6.8/250	25/250	25/250	36/250	36/250	36/250	36/250	36/250	50/250	100/250	100/250	400/250
	220/1/50	1.5/400	2/400	-	8/450	10/450	10/450	10/450	10/450	10/450	16/450	30/450	30/450	100/450
Weight (Kg)	W-proof	2.2	2.8	6	6	11	11	16.5	17	25.5	26.4	37	37	75
	Ex-proof	-	-	8	8	13	13	18.5	20	28.5	30	37	37	75
Weight (Lbs)	W-proof	4.3	5.5	13	13	24	24	36	37.5	56	57	81.5	81.5	165
	Ex-proof	-	-	17.5	17.5	28.5	28.5	40.5	44	62.5	66	81.5	81.5	165



EMERSON

Data sheet

Sheet No.: A5.104 Rev. 0
Date: March 2013

(Product Discontinued)

DIMENSIONS AND TECHNICAL DETAILS - ELECTRIC ACTUATOR

ELS

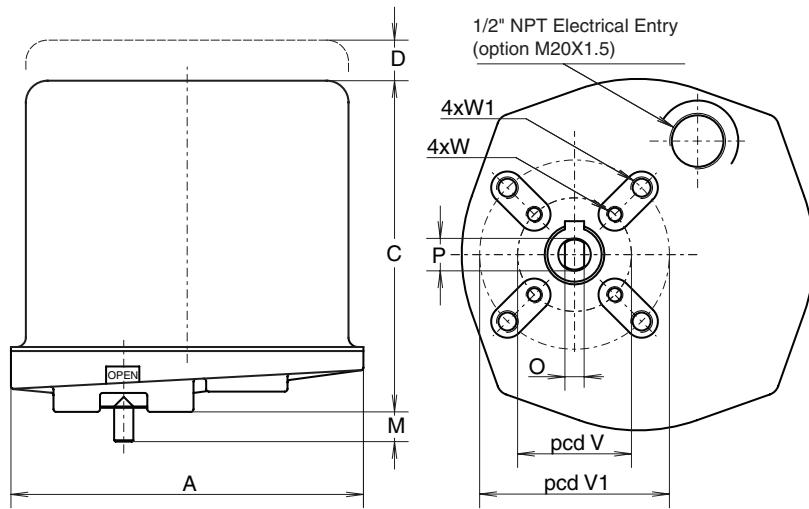

Bottom view

Dim in inches	ELS18		ELS25	
A	5.12		6.18	
B	4.82		5.31	
C	3.35		3.94	
D	0.44		0.51	
M	0.279		0.394	
O		+0.002 -0.000		+0.000 -0.004
P		+0.002 -0.000		+0.000 -0.004
Vstd	2.114		1.969	
V1	-		2.756	
W	10-24UNC x .43		10-24UNC x .47	
W1	-		5/16-18UNC x .59	
Performance				
Torque (lb-in.)	Break	159	221	
	Run	124	177	
Speed (sec.)	50Hz	5.5	7.5	
Current (A)	120V AC	0.55	0.6	
	230V AC	0.1	0.3	
Weight (lb.)	4.9		6.2	

Description

Compact electrical actuators, especially designed for small two and three way ball valves and similar drives requiring 90 or 180 degrees of rotation from a single phase or DC. electrical supply.

The water tight, aluminum alloy housing with steel cover, contains the drive motor and spur gear box assembly together with the anti-condensation heater and main terminal strip. Two limit switches provide for position limiting and remote position indication, space is allowed for two extra switches or a potentiometer for additional position feed back.

General Specification

Rotation : 90°
: Adjustable by limit switches: 10° to 320°

Enclosure : NEMA 4 (CSA approved)

Temperature : -4° to +158°F

Electrical connections : By 8 point internal terminal strip

Voltages : 24VDC or 24VAC

Single phase : 110-130V 50Hz or 60Hz
: 220-240V 50Hz or 240-280V 60Hz

Duty rating : 50%

Stroke limitation : By limit switches

Visual indication : By direction arrow on the drive spindle

Indication switches : 2, at 10 or 16 Amp. (at 120/240V AC) SPDT

Stall protection : By motor thermostat

Minimum Switch

Contactor Rating : 16A

Materials : Base plate : Aluminum alloy
: Cover : Steel
: Drive spindle : Stainless steel
: Fastenings, etc. : Stainless steel

Finish

Life : Two part polyurethane finish
: 100,000 operations minimum

Heater : 10 Watt (Option)

Options : Extra switches, potentiometer

ELMatic™



EMERSON™

Data sheet

Sheet No.: A5.103 Rev. D
Date: March 2014

(Product Discontinued)

DIMENSIONS AND TECHNICAL DETAILS - ELECTRIC ACTUATOR

EL

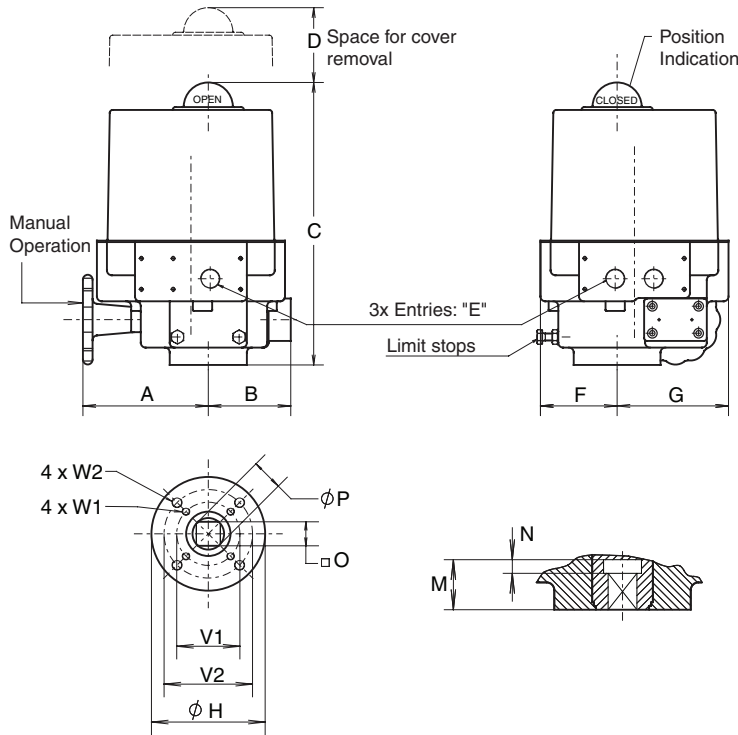

Dim in inches	EL35 & 55	EL100	EL150	EL200	EL350	EL500	EL800
A	5.07	5.31	5.31	6.69	6.69	7.68	7.68
B	2.35	3.23	3.23	4.29	4.29	5.04	5.04
C	10.5	11.50	11.50	12.40	12.40	12.52	14.02
D	5.71	6.50	6.50	6.50	6.50	6.50	7.48
3x E	1/2"NPT	1/2"NPT	1/2"NPT	3/4"NPT	3/4"NPT	3/4"NPT	3/4"NPT
F	2.68	3.03	3.03	3.78	3.78	4.84	4.84
G	3.61	4.72	4.72	5.53	5.53	6.54	6.54
H	3.54	3.54	3.54	4.92	4.92	5.91	5.91
M	1.08	1.30	1.30	1.30	1.30	1.89	1.89
N	0.35	0.35	0.35	0.35	0.35	-	-
O max.	0.556	0.752	0.752	0.752	0.752	1.068	1.068
O min.	0.551	0.748	0.748	0.748	0.748	1.063	1.063
P	0.709	0.984	0.984	0.984	0.984	1.417	1.417
V1	1.969	1.969	1.969	2.756	2.756	4.016	4.921
V2	2.756	2.756	2.756	4.016	4.016	-	-
W1	1/4-20 x .47	1/4-20 x .47	1/4-20 x .47	5/16-18 x .59	5/16-18 x .59	3/8-16 x .71	1/2-13 x .79
W2	5/16-18 x .59	5/16-18 x .59	5/16-18 x .59	3/8-16 x .71	3/8-16 x .71	-	-

Description

Type EL electric actuators use worm and wormwheel reduction gearing to provide tight positioning control and the self locking feature necessary for controlling larger valves, in particular butterfly valves.

The housing consists of an aluminium base casting and a steel cover, this contains the drive motor and worm gear assembly, together with the anti-condensation heater and main terminal block.

EL actuators takes the full range of control options, they have handwheel geared manual overrides, mechanical end position stops and position indication by a raised dome in the top cover.

General Specification

- Nominal Rotation : 90° - factory set to ±3°
- : Adjustable by limit switches: 10° to 320°
- Enclosure : NEMA 4
- Temperature range : -4° to +158° F
- Electrical connections : By 12 and/or 16 point terminal block
- Finish : Two part polyurethane
all steel parts zinc plated
- Life : 50,000 cycles minimum
- Limit switches : 4x SPDT V3 micro switches
- Torque switches : 2x SPDT V3 micro switches (Not on EL-20 & EL-55)
- Stall protection : By thermostat in motor windings
- Heater : 10 Watt
- Motor voltages and types
 - DC : 24VDC
 - AC Single phase : 24VAC 50/60Hz
: 110-130VAC 50/60Hz
: 220-280VAC 50/60Hz
 - AC Three phase : 380-460VAC 50/60Hz

Materials

- Housing : Aluminium alloy
- Cover : Steel
- Drivesleeve : Bronze
(Cast Iron)
- Fastenings : Stainless steel

Minimum customer switch or contactor rating 16Amp.

Performance		EL35	EL55	EL100	EL150	EL200	EL350	EL500	EL800
Torque (lb-in)	Break	310	487	885	1328	1770	3098	4425	7081
	Run	112	177	310	469	620	1089	1549	2478
Speed (Sec.)	50Hz	6	6	7.5	9	13.5	22	25.5	25.5
	110V AC	1.1	-	2.9	2.9	2.9	2.9	2.9	4.5
	230V AC	-	0.6	1.7	1.7	1.7	1.7	1.7	2.3
Current (A) (Max.)	24V DC	-	5	8	8	8	8	8	-
	110V AC	100	-	225	225	225	225	225	315
	230V AC	-	72	200	200	200	200	200	305
Power (W)	24V DC	-	45	118	118	118	118	118	-
	Switches-Indication	4x16A	4x16A	4x16A	4x16A	4x16A	4x16A	4x16A	4x16A
Torque SPDT at 110/240VAC		-	-	2x16A	2x16A	2x16A	2x16A	2x16A	2x16A
Weight (lb.)		13	13	24	24	36	37	56	57
Duty rating		30%	30%	30%	30%	30%	30%	30%	30%



EMERSON

Data sheet

Sheet No.: A5.103.2 Rev. B
Date: February 2012

(Product Discontinued)

DIMENSIONS AND TECHNICAL DETAILS

EL 1200/1600

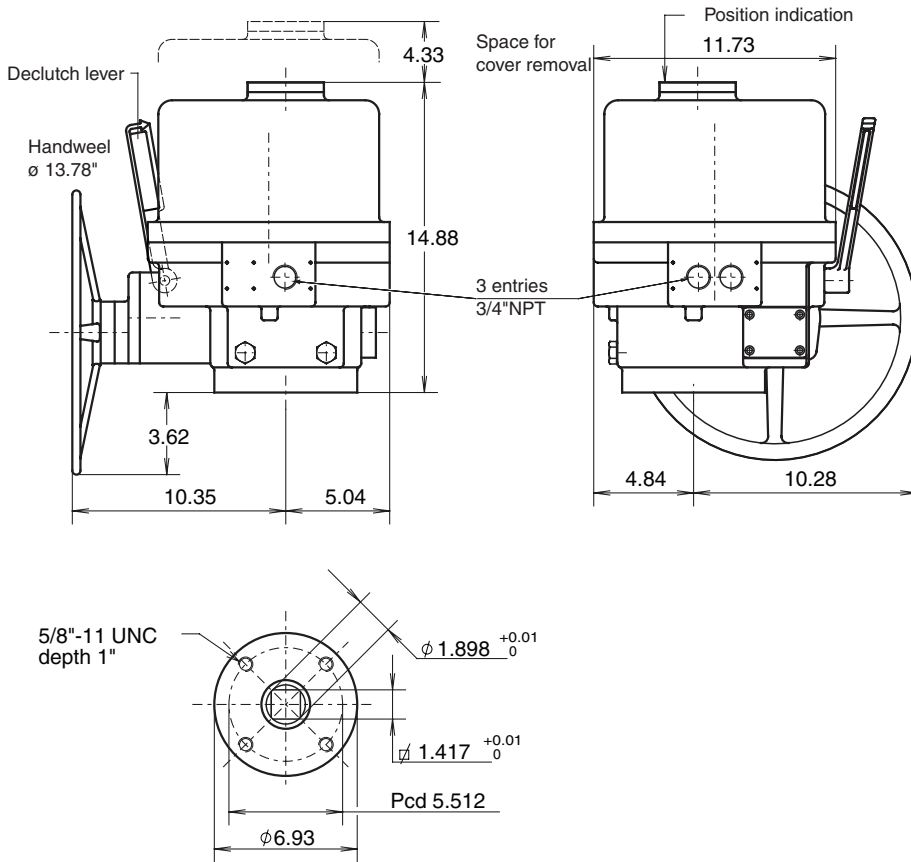

Description

EL-1200 actuators use worm and wormwheel reduction gearing to provide tight positioning control and the self locking feature necessary for controlling larger valves, particularly butterfly types.

The housing is of two aluminum castings, it contains the drive motor and worm gear assembly, together with the anti-condensation heater and main terminal strip.

EL-1200 actuator takes the full range of control options, it has mechanical end position stops and torque switches. Visual position indication is by a window in the top cover.

A geared manual override is fitted as standard, it is engaged by means of a declutching lever. When the motor is energized the unit automatically returns to motor operation, thus ensuring operator safety.

General Specification

- Nominal Rotation : 90° - factory set to ±3°
- : Adjustable by limit switches: 10° to 320°
- Enclosure : NEMA 4
- Temperature range : -4° to +158° F
- Electrical connections : By 12 and 16 point internal terminal strip
- Cable entries : 3x 1" NPT (optional 3x M25 or 3x PG21)
- Life : 50.000 operations minimum
- Heater : 10 Watt
- Voltages
 - Single phase : 110-130VAC 50/60Hz
 - : 220-280VAC 50/60Hz
 - Three phase : 380-460VAC 50/60Hz
- Other voltages : On request
- Stall protection : By torque switches and motor thermostat

Materials

- Housing : Aluminum alloy
- Cover : Aluminum alloy
- Fastenings : Stainless steel
- Finish : Two part polyurethane

Minimum customer switch or contactor rating 16Amp.

Voltage/phase/Hz.		120/1/60	230/1/50	380/3/50	460/3/60
Current (A)	break	14	7	2.8	1.1
	run	5.8	2.5	0.6	0.72
Power consumption (W)		535	450	220	266
Power factor		0.83	0.92	0.55	0.53
Operation time	(sec.)	21.5	25.5	25.5	21.5

Technical data		EL1200	EL1600
Torque (lb-in.)	Break	10621	14161
	Run	3717	4956
Limit switches	4x SPDT	16A	16A
Torque switches	2x SPDT	16A	16A
Weight Kg		81.6	81.6
Duty		30%	30%
Drive sleeve		Cast Iron	Bronze

EL Matic™

EMERSON™

Data sheet

Sheet No.: A5.103.1 Rev.A
Date: November 2009

(Product Discontinued)

DIMENSIONS AND TECHNICAL DETAILS

EL 2500

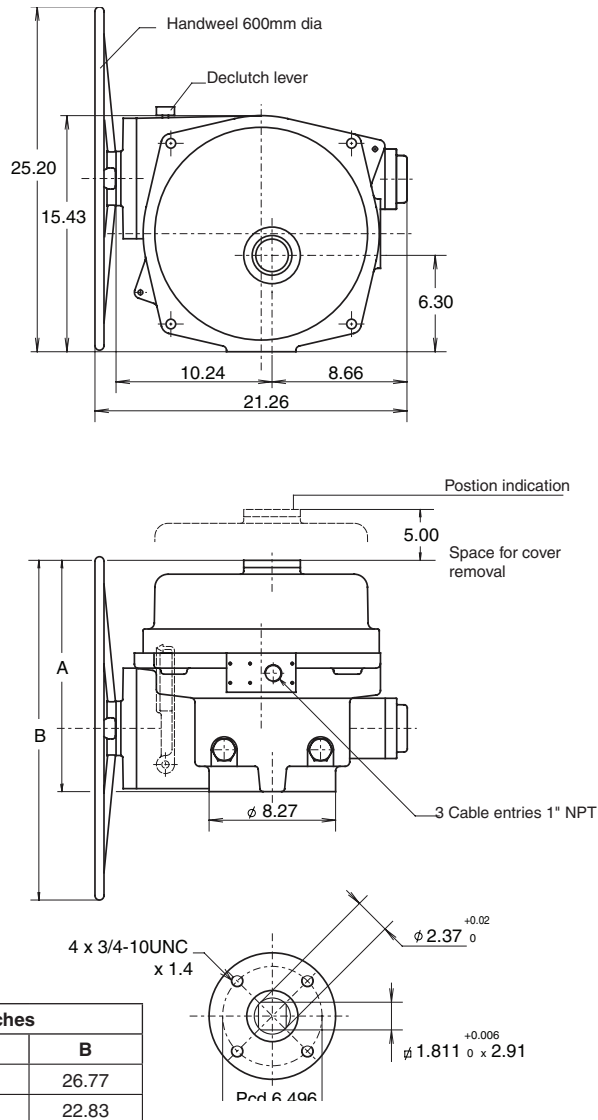

Dim. in inches		
	A	B
110/230V	19.09	26.77
380/460V	15.16	22.83

Description

EL-2500 actuators use worm and wormwheel reduction gearing to provide tight positioning control and the self locking feature necessary for controlling larger valves, particularly butterfly types.

The housing is of two aluminum castings, it contains the drive motor and worm gear assembly, together with the anti-condensation heater and main terminal strip.

EL-2500 actuator take the full range of control options, it has mechanical end position stops and torque switches. Visual position indication is by a window in the top cover.

A geared manual override is fitted as standard, it is engaged by means of a declutching lever. When the motor is energized the unit automatically returns to motor operation, thus ensuring operator safety.

General Specification

- Nominal Rotation : 90° - factory set to ±3°
: Adjustable by limit switches: 10° to 320°
 - Enclosure : NEMA 4
 - Temperature range : -4° to +158° F
 - Electrical connections : By 12 and 16 point internal terminal strip
 - Cable entries : 3x 1" NPT (optional 3x M25)
 - Life : 50.000 operations minimum
 - Heater : 20 Watt
 - Voltages
 - Single phase : 110-130V 50Hz or 60Hz
: 220-240V 50Hz or 240-280V 60Hz
 - Three phase : 380-415V 50Hz or 415-460V 60Hz
 - Other voltages : On request
 - Stall protection : By torque switches and motor thermostat
- Minimum customer switch or contactor rating 16Amp.**

Technical data

- Break torque : 22127 in.lb
- Run torque : 7744 in.lb
- Limit switches : 4x 16 A SPDT
- Weight : 165.3 lb
- Duty : 30%
- Torque switches : 2x 16 A SPDT (adjust. from 13276 to 22127 in.lb)

Voltage/phase/Hz.		120/1/60	230/1/50	380/3/50	460/3/60
Current (A)	break	58	27	9	2
	run	8	6	1.5	1.6
Power consumption (W)		720	792	560	600
Power factor		0.74	0.5	0.67	0.6
Operation time (sec.)		22.5	28	28	22.5

EL Matic™

EMERSON™

Data sheet

Sheet No.: A5.105 Rev. D
Date: May 2015

(Product Discontinued)

DIMENSIONS AND TECHNICAL DETAILS - ELECTRIC ACTUATOR

EL Exd

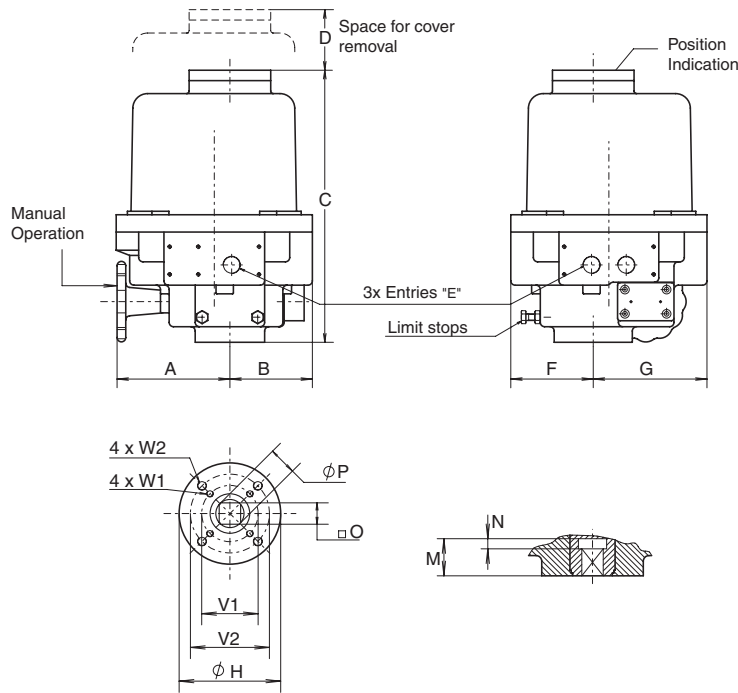

Description

Type EL actuators use worm and wormwheel reduction gearing to provide tight positioning control and the self locking feature necessary for controlling larger valves, particularly butterfly types.

The explosion proof housing consists of two aluminum castings, this contains the drive motor and worm gear assembly, together with the anti-condensation heater and main terminal strip.

EL actuators take the full range of control options, they have handwheel geared manual overrides, mechanical end position stops and torque switches on all the larger sizes. Visual position indication is by a window in the top cover.

General Specification

Nominal Rotation	: 90° - factory set to ±3°	Stall protection	: By motor thermostat (all sizes)
	: Adjustable by limit switches 10° to 320°		: By thermostat and by torque switches (EL 100-800)
Explosion proof	: II 2 G Ex db IIB T4, suitable for ATEX Zones 1, 2 (gas)	Identification	: Ex: EL 200 Exd
Certificate nr.	: DEKRA 12ATEX0001 X		
Enclosure	: IP67 (Optional: IP68)		
Temperature	: -4°F to + 140°F		
Connections	: By 12 and/or 16 point internal terminal strip		
Finish	: Two component polyurethane coating		
Life	: 50,000 operations minimum		
Heather	: 10 Watt		
Motor voltages and types			
- DC	: 24VDC		
- AC Single phase	: 24VAC 50/60Hz		
	: 110-130VAC 50/60Hz		
	: 220-280VAC 50/60Hz		
- AC Three phase	: 380-460VAC 50/60Hz		

Minimum customer switch or contactor rating 16Amp.

Dim in inches	EL35 & 55	EL100	EL150	EL200	EL350	EL500	EL800
A	5.04	5.31	5.31	7.28	7.28	7.68	7.68
B	2.80	3.94	3.94	4.29	4.29	5.04	5.04
C	10.83	11.42	11.50	12.40	12.40	14.96	14.96
D	5.71	6.50	6.50	6.50	6.50	6.50	7.48
3x E	1/2"NPT	1/2"NPT	1/2"NPT	3/4"NPT	3/4"NPT	3/4"NPT	3/4"NPT
F	3.06	3.03	3.03	3.78	3.78	4.84	4.84
G	4.10	4.72	4.72	5.53	5.53	6.54	6.54
H	3.54	3.54	3.54	4.92	4.92	5.91	5.91
M	1.08	1.30	1.30	1.30	1.30	1.77	1.77
N	0.35	0.35	0.35	0.35	0.35	-	-
O max.	0.556	0.752	0.752	0.752	0.752	1.068	1.068
O min.	0.551	0.748	0.748	0.748	0.748	1.063	1.063
P	0.709	0.984	0.984	0.984	0.984	1.417	1.417
V1	1.969	1.969	1.969	2.756	2.756	4.016	4.921
V2	2.756	2.756	2.756	4.016	4.016	-	-
W1	1/4-20 x .47	1/4-20 x .47	1/4-20 x .47	5/16-18 x .59	5/16-18 x .59	3/8-16 x .71	1/2-13 x .79
W2	5/16-18 x .59	5/16-18 x .59	5/16-18 x .59	3/8-16 x .71	3/8-16 x .71	-	-

Performance		EL35	EL55	EL100	EL150	EL200	EL350	EL500	EL800
Torque (lb-in)	Break	310	487	885	1328	1770	3098	4425	7081
	Run	112	177	310	469	620	1089	1549	2478
Speed (Sec.)	50Hz	6	6	7.5	9	13.5	22	25.5	25.5
	110V AC	1.1	-	2.9	2.9	2.9	2.9	2.9	4.5
	230V AC	-	0.6	1.7	1.7	1.7	1.7	1.7	2.3
Current (A) (Max.)	24V DC	-	5	8	8	8	8	8	-
	110V AC	100	-	225	225	225	225	225	315
	230V AC	-	72	200	200	200	200	200	305
Power (W)	24V DC	-	45	118	118	118	118	118	-
	Switches-Indication	4x16A	4x16A	4x16A	4x16A	4x16A	4x16A	4x16A	4x16A
Torque SPDT at 110/240VAC		-	-	2x16A	2x16A	2x16A	2x16A	2x16A	2x16A
Weight (lb.)		16	16	27	27	41	44	61	69
Duty rating		30%	30%	30%	30%	30%	30%	30%	30%



Data sheet

Sheet No.: A5.105.1 Rev. B
Date: February 2012

(Product Discontinued)

DIMENSIONS AND TECHNICAL DETAILS - ELECTRIC ACTUATOR

EL Exd

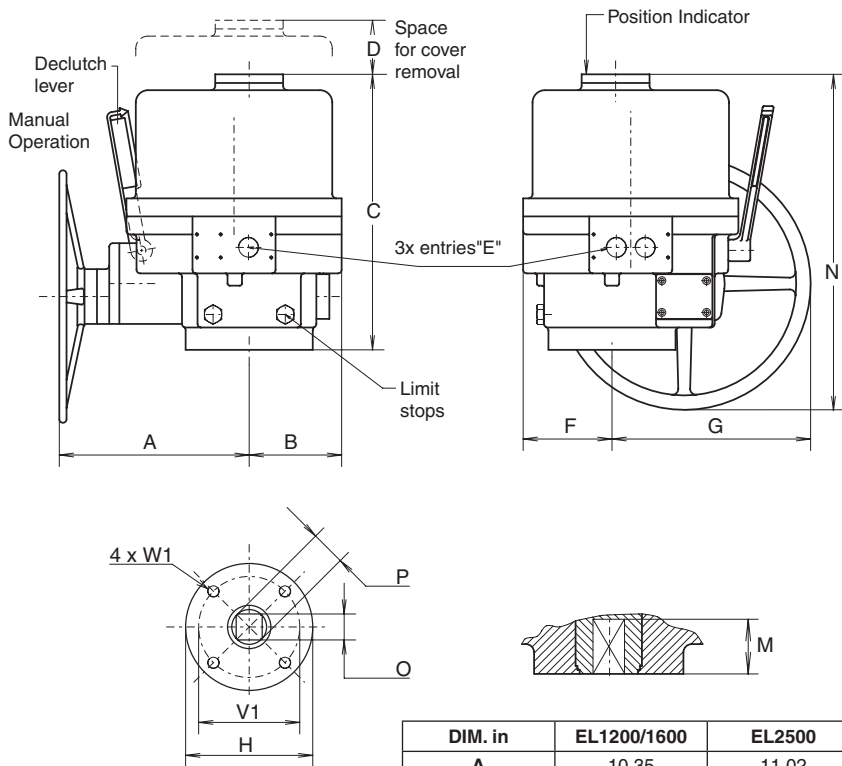

DIM. in	EL1200/1600	EL2500
A	10.35	11.02
B	5.04	8.66
C	14.88	19.09
D	4.33	5.12
E	3x3/4"NPT	3x3/4"NPT
F	4.84	5.04
G	10.28	12.76
H	6.93	8.27
M	2.44	2.91
N	18.50	26.77
O max.	1.417	1.811
O min.	1.424	1.817
P	1.898	2.370
V1	5.512	6.496
W1	5/8"-11 x 1	3/4"-10 x 1.4

Description

Type EL actuators use worm and wormwheel reduction gearing to provide tight positioning control and the self locking feature necessary for controlling larger valves, particularly butterfly types.

The explosion proof housing consists of two aluminum castings, this contains the drive motor and worm gear assembly, together with the anti-condensation heater and main terminal strip.

EL actuators take the full range of control options, they have handwheel geared manual overrides, mechanical end position stops and torque switches on all the larger sizes. Visual position indication is by a window in the top cover.

General Specification

Nominal Rotation	: 90° - factory set to $\pm 3^\circ$: Adjustable by limit switches 10° to 320°
Explosion proof	: II 2 G Ex db IIB T4 suitable for ATEX Zones 1, 2 (gas)
Certificate nr.	: DEKRA 12ATEX0001 X
Enclosure	: IP67 (Optional: IP68)
Temperature	: -4°F to + 140°F
Connections	: By 12 and 16 point internal terminal strip
Finish	: Two component polyurethane coating
Life	: 50,000 operations minimum
Heather	: 10 Watt
Voltages	- Single phase : 110-130VAC 50/60Hz : 220-280VAC 50/60Hz - Three phase : 380-460VAC 50/60Hz
Other voltages	: On request
Stall protection	: By torque switches and motor thermostat
Identification	: Example: EL1200 Exd

Minimum customer switch or contactor rating 16Amp.

Performance		EL1200/1600	EL2500
Torque (lb-in)	Break	10621/14161	22127
	Run	3717/4717	7744
Speed (Sec.)	50Hz	25.5	28
Current (A)	220V AC	7	27
	(Max.) 380 3ph	2.8	9
Power (W)	220V AC	450	792
	Switches-Indication	4x16A	4x16A
Torque SPDT at 110/240VAC		2x16A	2x16A
Weight (lb.)		81.5	165
Duty rating		30%	30%

EL Matic™

EMERSON™

Data sheet

Sheet No.: A5.105.2 Rev. C
Date: March 2014

(Product Discontinued)

DIMENSIONS AND TECHNICAL DETAILS - ELECTRIC ACTUATOR

EL FM

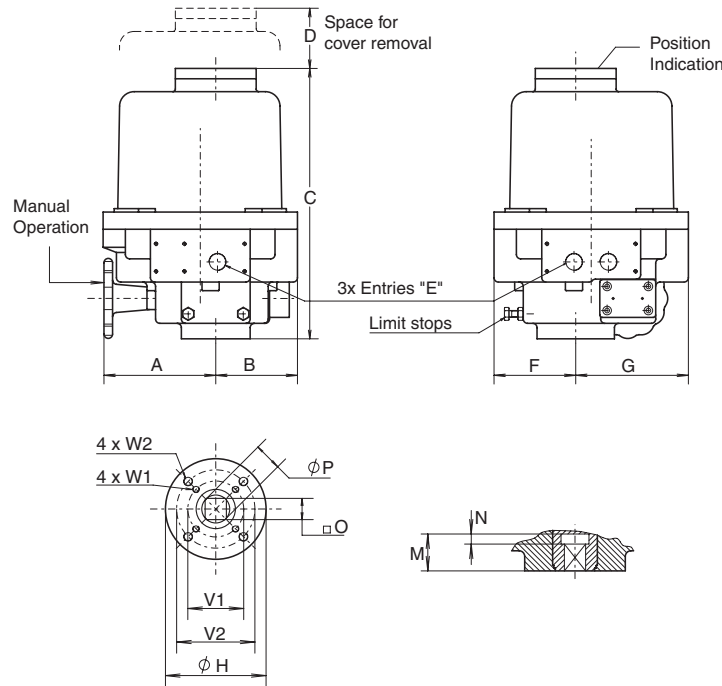

Dim in inches	EL35 & 55	EL100	EL150	EL200	EL350	EL500	EL800
A	5.04	5.31	5.31	7.28	7.28	7.68	6.97
B	2.80	3.94	3.94	4.29	4.29	5.04	5.04
C	10.83	11.42	11.50	12.40	12.40	14.96	14.96
D	5.71	6.50	6.50	6.50	6.50	6.50	6.30
E	1/2"NPT	1/2"NPT	1/2"NPT	3/4"NPT	3/4"NPT	3/4"NPT	3/4"NPT
F	3.06	3.03	3.03	3.78	3.78	4.84	4.84
G	4.10	4.72	4.72	5.53	5.53	6.54	6.54
H	3.54	3.54	3.54	4.92	4.92	4.92	4.92
M	1.08	1.30	1.30	1.30	1.30	1.77	1.77
N	0.35	0.35	0.35	0.35	0.35	-	-
O max.	0.556	0.752	0.752	0.752	0.752	1.068	1.068
O min.	0.551	0.748	0.748	0.748	0.748	1.063	1.063
P	0.709	0.984	0.984	0.984	0.984	1.417	1.417
V1	1.969	1.969	1.969	2.756	2.756	4.016	4.921
V2	2.756	2.756	2.756	4.016	4.016	-	-
W1	1/4-20 x .47	1/4-20 x .47	1/4-20 x .47	5/16-18 x .59	5/16-18 x .59	3/8-16 x .71	1/2-13 x .79
W2	5/16-18 x .59	5/16-18 x .59	5/16-18 x .59	3/8-16 x .71	3/8-16 x .71	-	-

Description

Type EL actuators use worm and wormwheel reduction gearing to provide tight positioning control. The self locking feature is necessary for controlling larger valves, particularly butterfly types.

The explosion proof housing consists of two aluminum castings, this contains the drive motor and worm gear assembly, together with the anti-condensation heater and main terminal strip.

EL actuators take the full range of control options, they have handwheel geared manual overrides, mechanical end position stops and torque switches on all the larger sizes. Visual position indication is by a window in the top cover.

General Specification

- Nominal Rotation : 90° - factory set to ±3°
- : Adjustable by limit switches 10° to 320°
- Explosion proof : Class I / Div. I, group C + D
- : Class II/III / Div. I, group E, F + G
- : FM Hazardous area classification is compliant to NEMA 7C and NEMA 7D ratings
- FM Approval : J.1.OTOA7.AE (3615)
- Temperature : -4° to +158°F
- Connections : By 12 and/or 16 point internal terminal strip
- Finish : Two component polyurethane coating
- Life : 50,000 operations minimum
- Heater : 10 Watt
- Voltages : 24VDC or 24VAC
- Single phase : 110-130VAC 50/60Hz
- : 220-280VAC 50/60Hz
- Three phase : 380-460VAC 50/60Hz
- Stall protection : By motor thermostat (all sizes)
- : By thermostat and by torque switches (EL 100-800)
- Identification : Example: EL 35 FM

Minimum customer switch or contactor rating 16Amp.

Performance		EL 35	EL100	EL150	EL200	EL350	EL500	EL800
Torque (In.lb.)	Break	487	885	1328	1770	3098	4425	7081
	Run	177	310	469	620	1089	1549	2478
Speed (Sec.)	50Hz	6	7.5	9	13.5	22	25.5	25.5
Current (A)	220V AC	0.6	1.7	1.7	1.7	1.7	1.7	2.3
	110V AC	1.1	2.9	2.9	2.9	2.9	2.9	4.5
Power (W)	220V AC	72	200	200	200	200	200	305
Switches-Indication		4x16A	4x16A	4x16A	4x16A	4x16A	4x16A	4x16A
Torque SPDT at 110/240VAC)		-	2x16A	2x16A	2x16A	2x16A	2x16A	2x16A
Weight (lb.)		16	27	27	41	44	61	69
Duty rating		30%	30%	30%	30%	30%	30%	30%



EMERSON

Data sheet

Sheet No.: A5.201 Rev.A
Date: November 2009

(Product Discontinued)

EL ACTUATOR WITH TWO EXTRA SWITCHES (Kit option)

XS

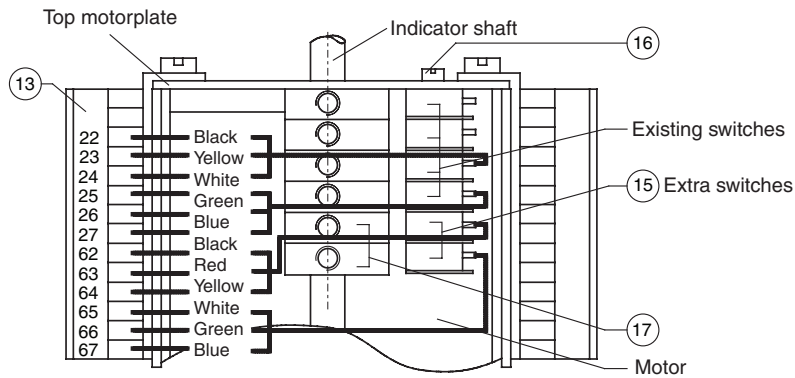

Description

This electric actuator variation has the addition of two extra switches, to obtain the total of 4 spare switches. This provides additional indication of the actuator (and therefore valve) position by means of a completely separate circuit.

Construction

The two new switches are fitted below the existing limit switches and are driven by their own cams on the indicator shaft.

The two new switches are wired to the terminal strip (13) and may be wired externally by one of the spare electrical entries. This is particularly important if the indication voltage is different from the power voltage.

Specification

Switches	Type	: V3
	Model	: V-162-1A5
	Voltage	: Up to 250V
	Current	: 16A max.
	Temperature	: -13°C to +176°F

Identification

- Factory Option : Add "+ XS" to the basic actuator size
: eg. EL100 220/60 + XS
- Kit Option : Actuator size is added to: "Kit, XS"
: eg. Kit, XS/EL 55 220/60

- Note**
- 1) When supplied as a kit option, all the components as shown are included, together with an instruction sheet
 - 2) Wiring diagram is shown with actuator in mid position
 - 3) Wiring diagram for EL55 220V 60Hz + XS

PC no	No req	Description
13	1	Marking tag
15	2	Micro switch
16	2	Stud
17	2	Cams

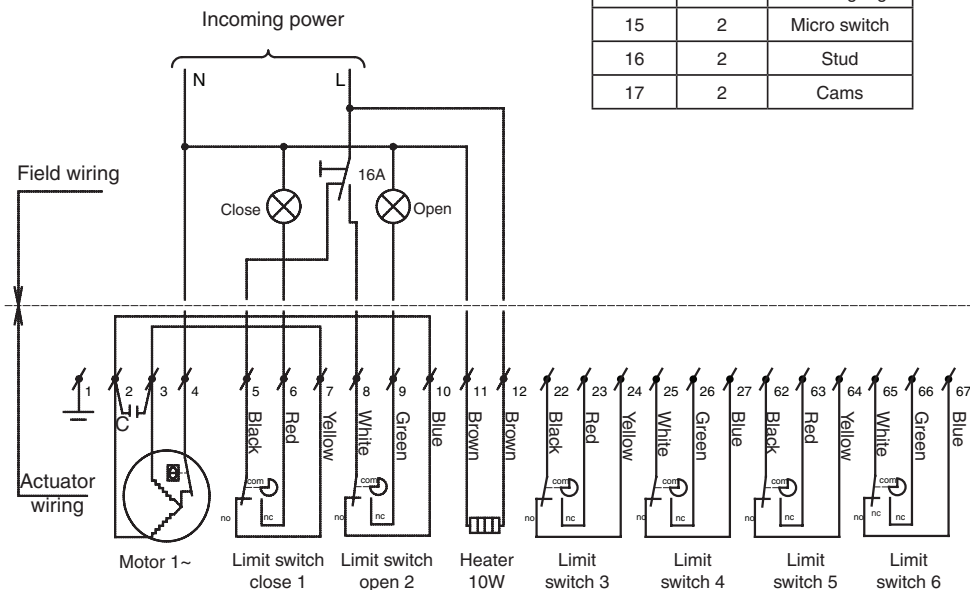

EL Matic™

EMERSON™

Data sheet

Sheet No.: A5.202 Rev.A
Date: November 2009

(Product Discontinued)

EL ACTUATOR WITH POTENTIOMETER (Kit option)

POT

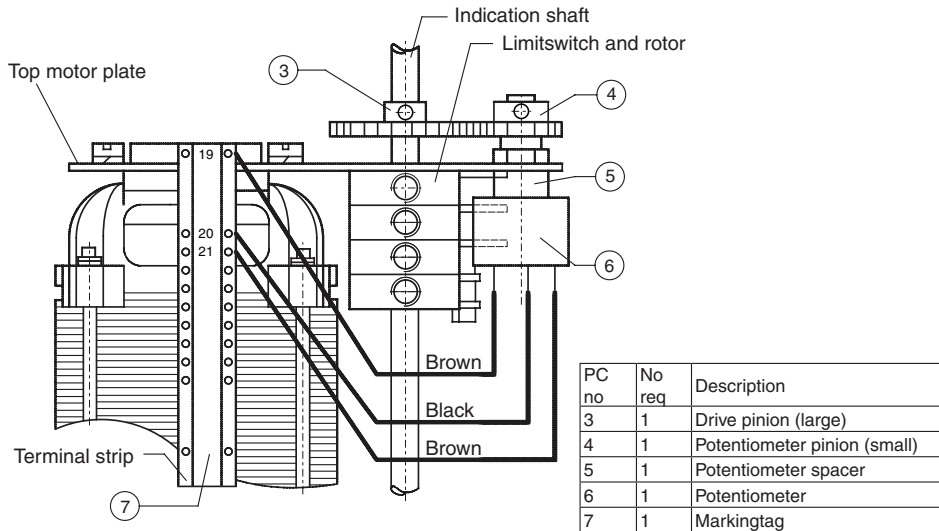

Description

This electric actuator variation has the addition of a potentiometer to provide continuous indication of the actuator (and therefore valve) position. When wired as shown a voltage signal will indicate an analog position.

Construction

The potentiometer is fitted into a pre-drilled hole in the top motor plate and driven, by a pair of spur gears, so that the 90° rotation of the indicator shaft turns the potentiometer spindle through it's full operational travel.

The potentiometer is wired to the terminal strip and may be wired externally via one of the spare electrical entries. This is particularly important if the indication voltage is different from the power voltage.

Specification

Potentiometer	Make	:	SFERNICE
	Voltage	:	Up to 350V
	Power	:	1 Watt
	Temperature	:	-4°F to +158°F
	Resistance	:	10KΩ (±20%)
	Type	:	Cermet
	Linearity	:	2%
	Mech. rotation	:	270°
	Electrical rotation	:	270°
	Max. terminal resistance	:	2Ω

Identification

- Factory Option : Add "+ POT" to the basic actuator size
: eg. EL 55 220/50 + POT
- Kit Option : Actuator size is added to: "Kit, POT"
: eg. Kit, POT/EL 55 120/50

- Note**
- 1) When supplied as a kit option, all the components as shown are included, together with an instruction sheet
 - 2) A special version is required for more than 90°
 - 3) Wiring diagram for EL55 120V/60Hz + POT

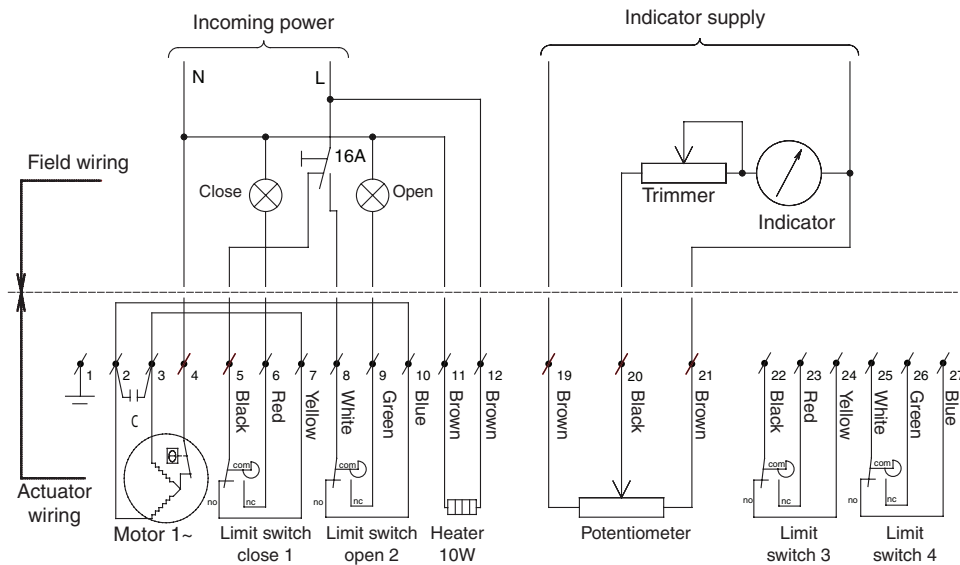

EL Matic™

EMERSON™

Data sheet

Sheet No.: A5.204 Rev.A
Date: November 2009

(Product Discontinued)

EL ACTUATOR WITH SPEED CONTROL TIMER - AC (Kit option)

SC

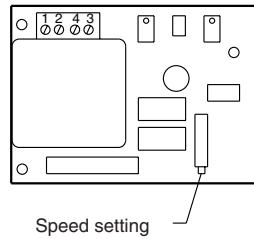
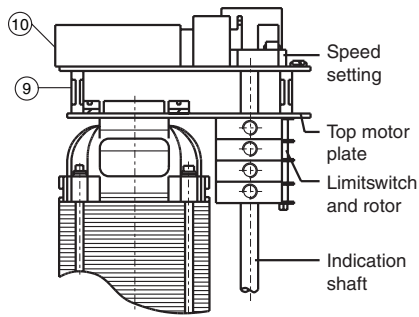

PC no	No req	Description	Used on
9	3	Print spacer	EL55
9	3	Spacer/screw	EL100/2500
10	1	Speed control board	EL55 EL100/2500

Description

This electric actuator variation has the addition of an electronic card, this is provided complete with a dual voltage (AC.) power supply, a trimmer for motor pulse adjustments and a triac for motor switching.

The circuit provides a timed ON/OFF switching cycle. The ON pulse is fixed at 0.5 sec and the OFF pulse is adjustable via the trimmer.

This adjustment is easily carried out with a small screwdriver, with the cover removed.

Construction

The circuit board is located on top of the motor plate and is wired directly to the terminal strip.

Specification

Voltage : 120 or 220V 50/60 Hz.

Temperature : -4°F to +158°F

Speed	Model	Min. sec.	Max. sec.
EL 55		11.5	255
EL 100		13.5	298
EL 150		17.0	383
EL 200		25.5	574
EL 350		41.5	936
EL 500		48.5	1085
EL 800		48.5	1085
EL 1200		48.5	1085
EL 1600		48.5	1085
EL 2500		53.0	1191

Identification

Factory Option : Add "+ SC" to the basic actuator size

: eg. EL100 220/60 + SC

Kit Option

: Actuator size is added to: "Kit, SC"

: eg. Kit, SC/EL100 120/60

- Note**
- 1) When supplied as a kit option, all the components as shown are included, together with an instruction sheet
 - 2) Wiring diagram is shown with actuator in mid position
 - 3) Wiring diagram for EL55 120V/60Hz + SC

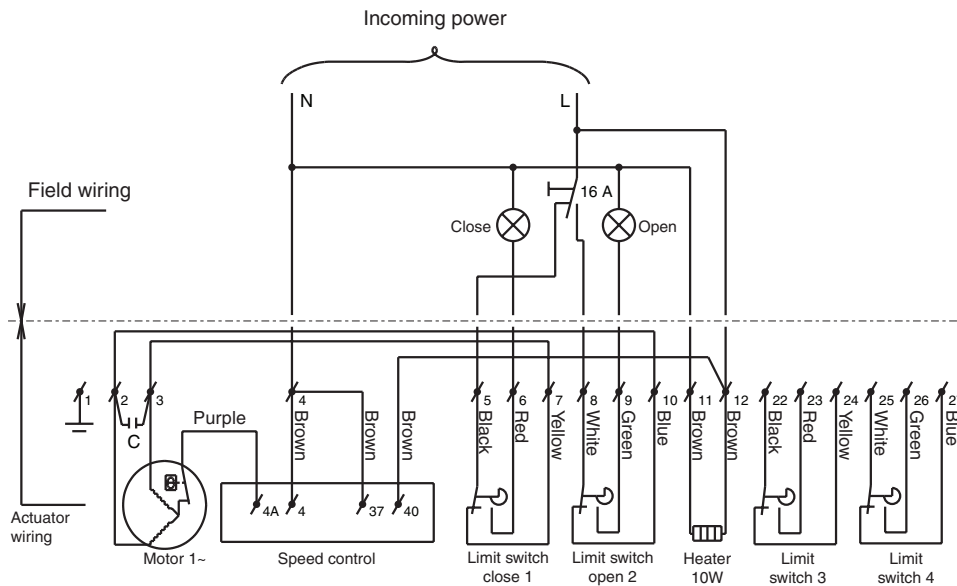

EL Matic™

EMERSON™

Data sheet

Sheet No.: A5.204.1 Rev.A
Date: November 2009

(Product Discontinued)

EL ACTUATOR WITH SPEED CONTROL TIMER - DC (Kit option)

SC

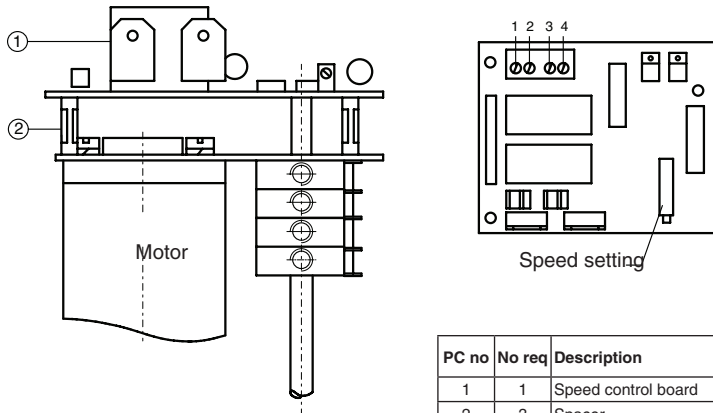

PC no	No req	Description	Used on
1	1	Speed control board	EL55
2	3	Spacer	EL100/500
2	3	Spacer/screw	EL55 EL100/500

Description

This electric actuator variation has the addition of a printed circuit board, complete with a trimmer for motor pulse adjustments and a relay and power transistor network for motor switching.

The circuit provides a timed ON/OFF switching cycle. The ON pulse is fixed at 0.5 sec and the OFF pulse is adjustable via the trimmer.

This adjustment is easily carried out with a small screwdriver, with the cover removed.

Construction

The circuit board is located on top of the motor plate and is wired directly to the terminal strip.

Specification

Voltage	: 24VDC		
Temperature	: -4°F to +158°F		
Speed	: Model	Min.	Max.
		sec.	sec.
	EL 55	10.5	202
	EL 100	14	263
	EL 150	17	323
	EL 200	25	485
	EL 350	42	808
	EL 500	38	727

Identification

- Factory Option : Add "+ SC-DC" to the basic actuator size
: eg. EL100 24VDC + SC-DC
- Kit Option : Actuator size is added to: "Kit, SC-DC"
: eg. Kit, SC-DC/EL55 24VDC

- Note**
- 1) When supplied as a kit option, all the components as shown are included, together with an instruction sheet
 - 2) Wiring diagram is shown with actuator in mid position
 - 3) Wiring diagram for EL100-EL500 24VDC + SC-DC

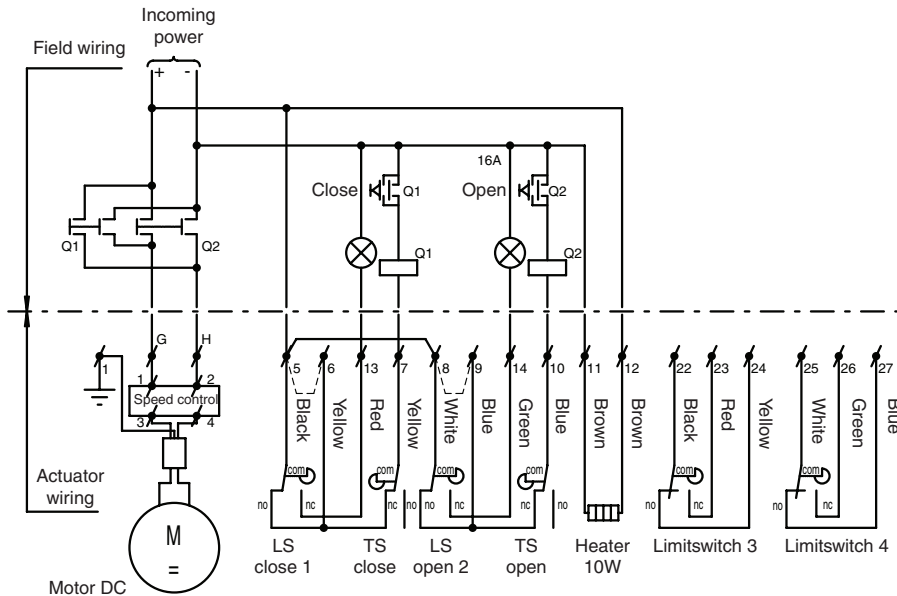

EL Matic™

EMERSON™

Data sheet

Sheet No.: A5.205.01 Rev.B
Date: February 2013

(Product Discontinued)

EL ACTUATOR WITH mA POSITION TRANSMITTER, 2-WIRE (Kit option)

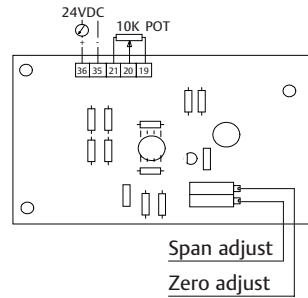
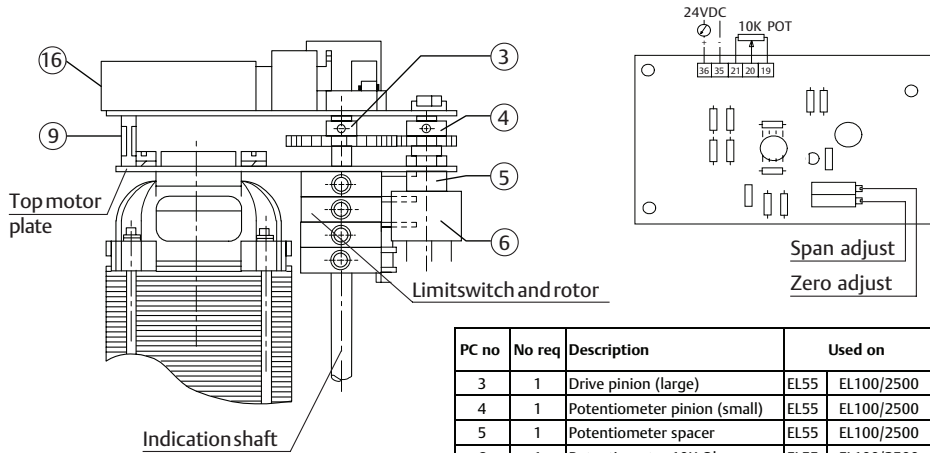

PC no	No req	Description	Used on	
3	1	Drive pinion (large)	EL55	EL100/2500
4	1	Potentiometer pinion (small)	EL55	EL100/2500
5	1	Potentiometer spacer	EL55	EL100/2500
6	1	Potentiometer 10K Ohm	EL55	EL100/2500
9	3	Printspacer	EL55	
9	3	Spacer/screw		EL100/2500
16	1	Position transmitter board	EL55	EL100/2500

Description

This electric actuator variation provides a continuous position indication by transmitting a 4 to 20 milli-Amp signal, this is proportional to the output shaft position.

This 2 wire version consists of a potentiometer and an electronic card fed from an external (24VDC.) power supply.

The card is equipped with trimmers for zero and span adjustment and terminals for the internal and external connections.

Construction

The potentiometer and circuit board located on the top motor plate are wired as shown, using the board's own terminal strip.

Specification

Input : 24VDC.
Output : 4 to 20 mA, with adjustable zero and span
Temperature : -4°F to +158°F
Potentiometer : 10KΩ (see sheet A5.202)

Identification

Factory Option : Add "+ PT2" to the basic actuator size
: eg. EL100 120/60 + PT2
Kit Option : Actuator size is added to: "Kit, PT2"
: eg. Kit, PT2/EL 55 120/60

- Note**
- 1) When supplied as a kit option, all the components as shown are included, together with an instruction sheet
 - 2) Wiring diagram is shown with actuator in mid position
 - 3) Wiring diagram for EL55 120V/50Hz + PT2

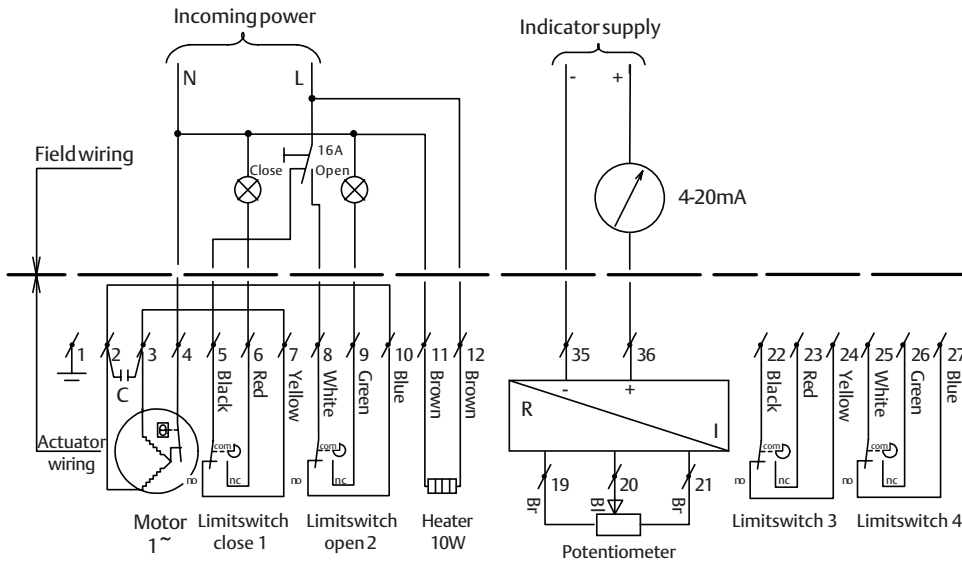

Data sheet

Sheet No.: A5.205.02 Rev.A
Date: November 2009

(Product Discontinued)

EL ACTUATOR WITH MA POSITION TRANSMITTER, 4-WIRE (Kit option)

PT4

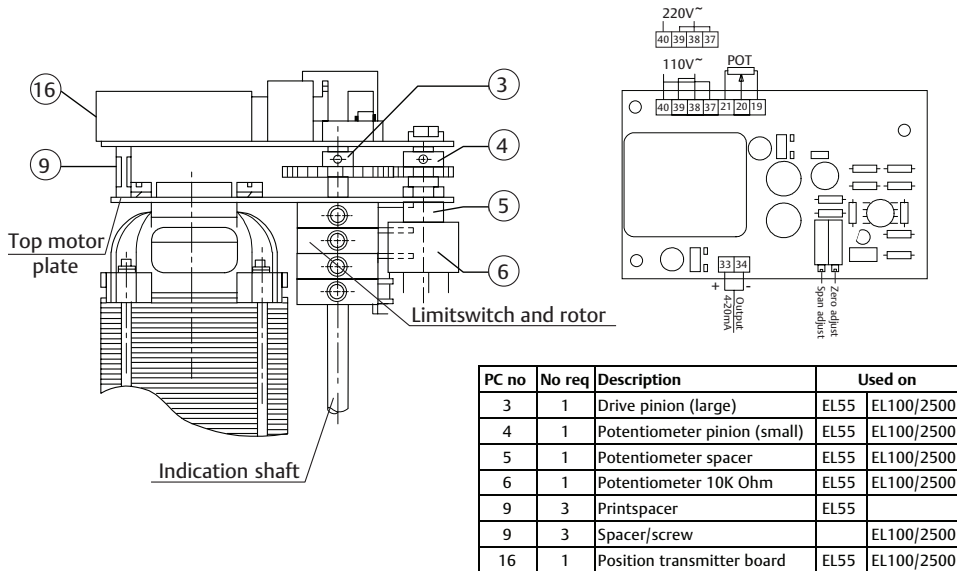

PC no	No req	Description	Used on	
3	1	Drive pinion (large)	EL55	EL100/2500
4	1	Potentiometer pinion (small)	EL55	EL100/2500
5	1	Potentiometer spacer	EL55	EL100/2500
6	1	Potentiometer 10K Ohm	EL55	EL100/2500
9	3	Printspacer	EL55	
9	3	Spacer/screw		EL100/2500
16	1	Position transmitter board	EL55	EL100/2500

Description

This electric actuator variation provides a continuous position indication by transmitting a 4 to 20 milli-Amp signal, this is proportional to the output shaft position.

This 4 wire version consists of a potentiometer and an electronic card complete with a dual voltage (AC.) power transformer, fed from the actuator's own incoming power supply.

The remaining two wires are used for the output position signal.

The card is equipped with trimmers for zero and span adjustment and terminals for the internal and external connections.

Construction

The potentiometer and circuit board located on the top motor plate are wired as shown, using the board's own terminal strip.

Specification

- Input : 120 or 220 V 50/60 Hz.
- Output : 4 to 20 mA, with adjustable zero and span
- Temperature : -4°F to +158°F
- Potentiometer : 10KΩ (see sheet A5.202)

Identification

- Factory Option : Add "+ PT4" to the basic actuator size
: eg. EL100 120/60 + PT4
- Kit Option : Actuator size is added to: "Kit, PT4"
: eg. Kit, PT4/EL55 220/50

- Note**
- 1) When supplied as a kit option, all the components as shown are included, together with an instruction sheet
 - 2) Wiring diagram is shown with actuator in mid position
 - 3) Wiring diagram for EL55 120V/60Hz + PT4

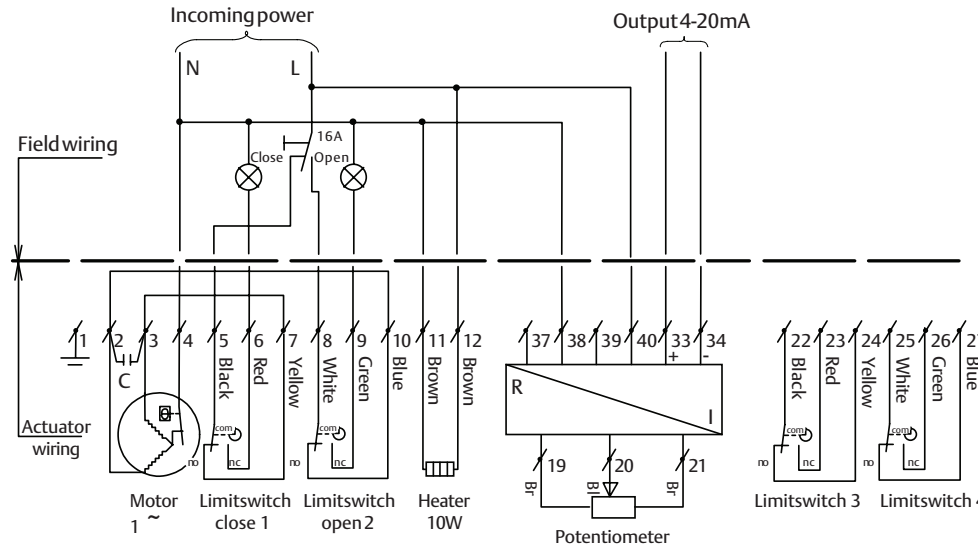

Link : For 220V nr. 37 & 39
: For 110V nr. 37 & 40 / nr. 38 & 39



Data sheet

Sheet No.: A5.206 Rev.A
Date: November 2009

(Product Discontinued)

EL ACTUATOR WITH MODULATING POSITIONER - (Kit option)

MOD

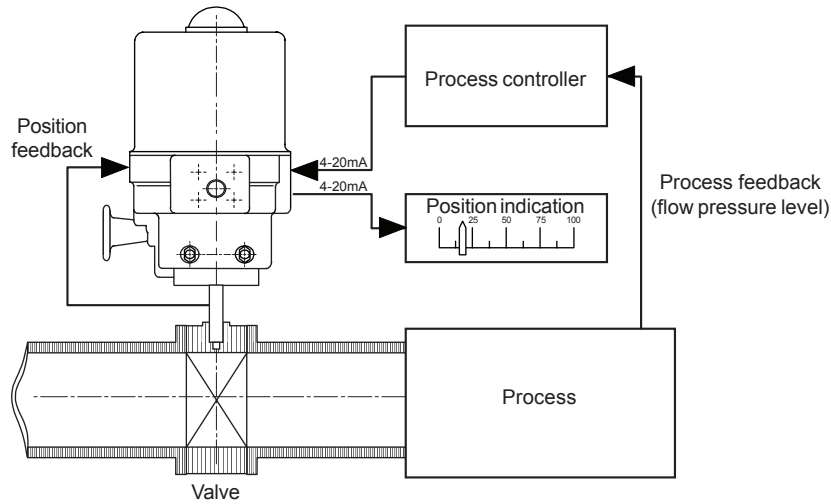

Wiring diagram for EL100-EL1600 + MOD

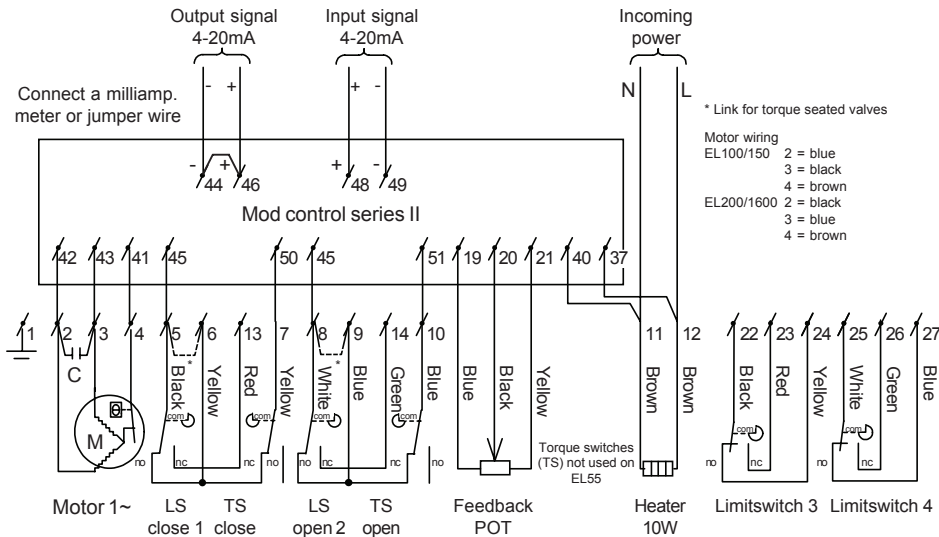

Description

This electric actuator variation provides a modulating position control from an incoming 4 to 20 milli-Amp signal.

A very advanced solid-state circuit control board works on the comparator principle, where the incoming control signal is continuously compared to the actual position of the output shaft and signals are sent to the motor to "Open more" or "Close more", until the balanced or null position is achieved.

The valve is held in this position until a variation in signal causes a proportional movement of the output shaft.

The circuit board includes trimmers for zero, span adjustment sensitivity adjustment and provision is made for split ranging. LED's are fitted for simplified setting.

A speed control feature reduces the motor speed, by pulsing the motor, as the null position is approached. This allows greater accuracy without "Overshoot" or "Hunting".

Other standard features include a 4-20 mA position transmitter and "Lock on last position" on signal failure.

Specification

Input Power	: Dual 220/240 - 120 50/60 Hz
	: Control 4 to 20 mA, adjustable
	: 0.1 to 35 mA
	: and 0.1 to 12 mA
	: or 12 to 35 (for split ranging)
Performance	: Linearity 3%
	: Hysteresis 1%
	: Min. resolution 1%
Adjustment	: Zero, span, sensitivity
Position indication	: 4 to 20 mA output
Temperature	: -20°F to +158°F

Identification

Factory Option	: Add "MOD" to the basic actuator size
	: eg. EL100 120/60 + MOD
Kit options	: Actuator size is added to: "Kit, MOD"
	: eg. Kit MOD/EL100 120/60



Data sheet

Sheet No.: A5.207 Rev.A
Date: November 2009

(Product Discontinued)

EL ACTUATOR WITH LOCAL CONTROL STATION - (Kit option)

LC

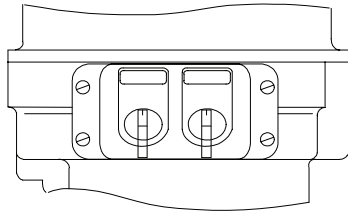
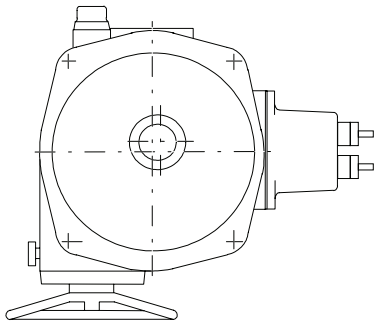

PC no	NO req	Description	PC no	NO req	Description
1	1	Seal	7	1	Marking tag
2	4	Screw	8	1	Selector knob
3	4	Lock washer	9	1	Selector knob
4	4	Contact block	10	1	Marking tag
5	1	Housing l.r.c.stat.	11	2	Adapter
6	2	Nameplate	12	1	Contact block

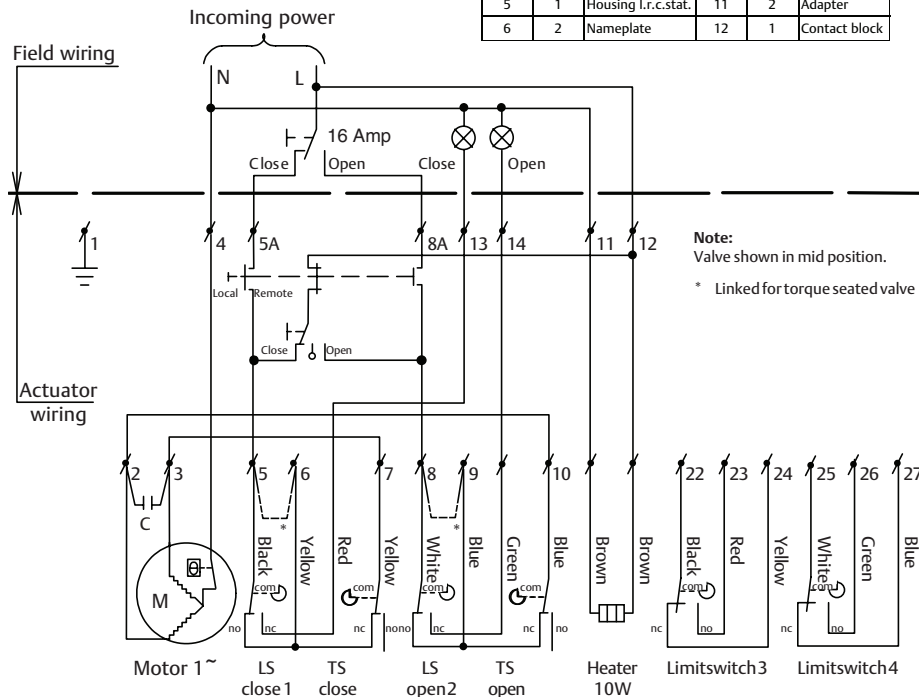

Description

This electric actuator variation has the addition of a local control box, which has two switches.

The first is a selector switch to switch between "LOCAL" and "REMOTE" operation of the actuator. When "LOCAL" is selected the second switch may be used to open, stop or close the valve, this switch is locked out when "REMOTE" is selected and the control is returned to the remote control station.

Construction

The control box is located on the side of the actuator casting and all the connection wiring is contained internally.

Specification

Switches: Make : Sprecher & Schuh
 First switch : LC1-10-10020NL
 Second switch : LC1-10-3501
 Voltage : Up to 600V
 Current : 10A max
 Temperature : -13°F to +140°F

Identification

Factory Option : Add "+ LC" to the basic actuator size
 : eg. EL100 120/60 + LC
 Kit Option : Actuator size is added to: "Kit, LC"
 : eg. Kit, LC/EL55 120/60

Variations

: Other switch inserts for key lock, etc.

Note

: When supplied as a kit option, all the components as shown are included, together with an instruction sheet
 : Wiring diagram for EL100-1600 120V/60Hz + LC



Data sheet

Sheet No.: A5.207.1 Rev. B
Date: February 2012

(Product Discontinued)

EL EX-PROOF ACTUATOR WITH LOCAL CONTROL STATION (FLAME-PROOF Ex d) LC-Ex

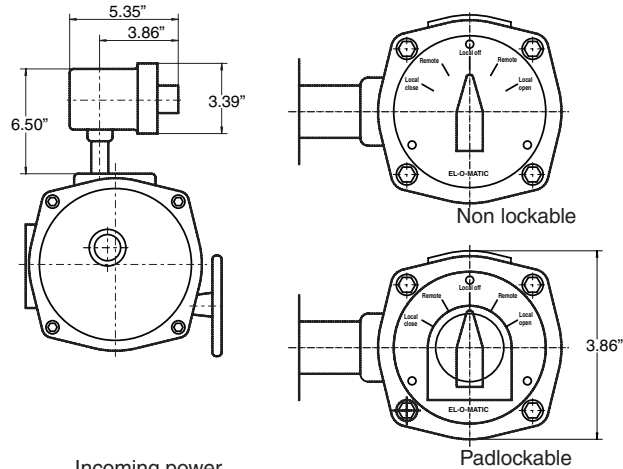

Description

This electric actuator variation for use on an explosion proof actuator has the addition of a local control box, with a single rotary 5 position switch with 5 SPST contacts.

The switch selects between: "LOCAL OPEN", "REMOTE", "OFF", "REMOTE" and "LOCAL CLOSE".

When in "LOCAL OPEN" or "LOCAL CLOSE" position the actuator can not be operated remotely.

This local control station is certified flame proof according to EN50014 and EN50018 and bears ATEX marking II 2 G Ex db IIB T4.

Construction

The control station is located on the side of an ATEX II 2 G Ex db IIB T4 flame proof electric actuator and all the connection wiring is contained internally.

Specification

Switches	Type	: Santon
	Model	: H1 P-EE1
	Voltage	: Up to 600V
	Current	: 20A max. (resistive load)
	Temperature	: -4°F to + 140°F

Housing

Material	: Aluminum
Finish	: Two component polyurethane

Flame proof

Marking	: II 2 G Ex db IIB T4, suitable for ATEX Zones 1, 2 (gas)
Certificate nr.	: DEKRA 12ATEX0001 X
Actuator sizes	: EL 35, EL 55, EL100, EL150, EL200, EL350, EL500 and EL800

Identification

Factory Option	: Add "+ LC-Ex" (non lockable or "+LCL-Ex" (padlockable) to the basic actuator size eg. EL100 120/60 + LC-Ex
----------------	--

Note

- 1 This option is not supplied as a kit option, only as a factory option
- 2 Both local/remote and close/stop/open switches are combined into one switch
- 3 Wiring diagram for EL100-EL800 120V/60Hz + LC-Ex

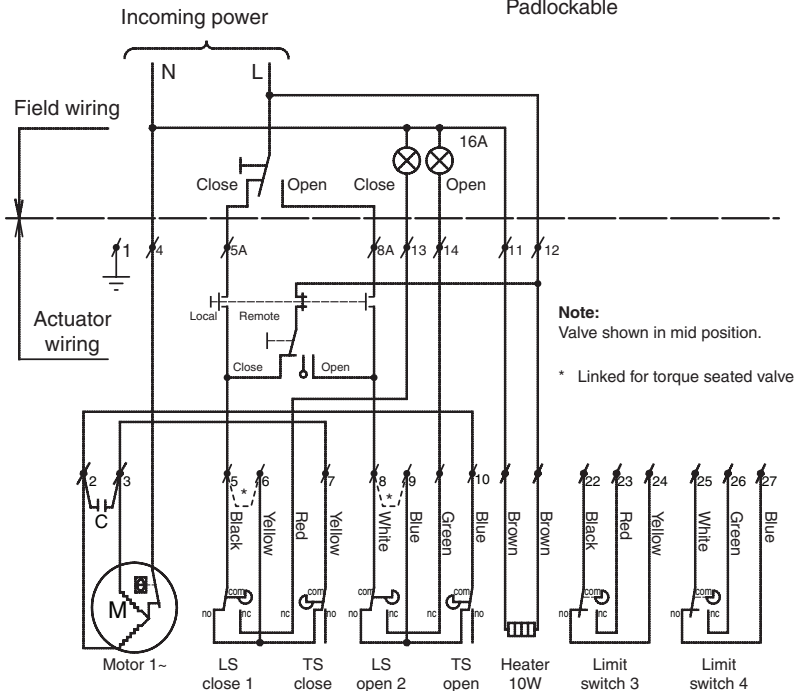

EL Matic™

EMERSON™