



# 316L Stainless Steel Redundant Control System (316L SST RCS)

## Operation & Maintenance Guide





**ASCO Valves®**

### TABLE OF CONTENTS

PRODUCT DESCRIPTION .....	3
SPECIFICATIONS: .....	5
NAMEPLATE INFORMATION.....	5
INSTALLATION.....	7
Section 1.00 Normally Closed .....	9
1. General Operation .....	9
2. Testing and Maintenance: .....	10
Section 2.00 .....	11
1. Functional Test Certification.....	11
2. Spare Parts .....	11
3. Packaging .....	12
4. Limited Warranty .....	12
5. Tools Required for Routine Service of RCS .....	13
RCS- R Wiring Diagram (A).....	14
RCS Normally Closed Piping Diagrams .....	16

## Documentation Conventions

This guide uses the following typographic conventions:

EXAMPLE	Description
<b>NOTE</b>	Notes containing supplementary information.
	This symbol precedes information about potential equipment damage.
	This symbol precedes information about potential personnel hazards.

## User Experience Prerequisites

To effectively use the Pneumatic 316L SST RCS, users should have some experience with pneumatic systems.

## Warnings!

**READ THIS ENTIRE MANUAL AND ALL RELATED PUBLICATIONS PERTAINING TO THE WORK TO BE PERFORMED BEFORE INSTALLING, OPERATING OR SERVICING THIS EQUIPMENT.**

- Follow all appropriate safety codes and standards.
- Failure to follow instructions may result in personal injury and/or property damage.
- Use extreme caution when working around power-input cables. These cables may have potentially lethal or dangerous voltages.
- Prior to energizing the equipment, have qualified personnel verify all wiring and connections against vendor drawings. Incorrect wiring and/or connections can result in equipment damage or serious system failure. If you have questions or need more information on installing and operating ASCO equipment, contact ASCO.

## PRODUCT DESCRIPTION

The 316L Stainless Steel Redundant Control System (hereafter referred to as 316L SST RCS) is a two-out-of-two (2oo2) or one-out-of-one hot standby (1oo1 HS) voting, solenoid-operated valve system designed for use as a component in

safety instrumented systems. It functions as a redundant pneumatic tripping device to control the pilot air signal to a process valve actuator. The 316L SST RCS uses 2oo2 or 1oo1 HS voting solenoids to enhance the reliability of the circuit. The 316L SST RCS consists of two electrically actuated solenoid valves (SOV1, SOV2) and a pneumatically operated (Manually Controlled) bypass valve, and three pressure switches. The pressure switches provide solenoid state feedback and are used during on-line testing of the 316L SST RCS unit. The bypass valve allows for maintenance of the solenoid valves without having to shut down the process valve. The use of the Maintenance Bypass Valve is not required for functional testing of the 316L SST RCS unit. The 316L SST RCS is available as a base unit (5R) only.

### Under normal operating conditions:

The 316L SST RCS allows for periodic testing of the solenoids by cycling one solenoid valve and then the other either manually or automatically therefore attaining the desired safety availability. This testing is performed online without the need for bypassing of the safety action and without interruption of the process.

For all constructions, three pressure switches are included to provide indication of each solenoid-operated valve and bypass valve position.

**Normally Closed Construction:** the 316L SST RCS supplies air (hereafter referred to as media) to the process valve actuator through the “Process” port when energized.

### When a trip occurs:

**Normally Closed Construction:** the 316L SST RCS blocks the incoming pneumatic signal and connects the “Process” port to the “Exhaust” port. This vents the media signal from the process valve actuator and allows the actuator return spring to move the process to its fail-safe position.

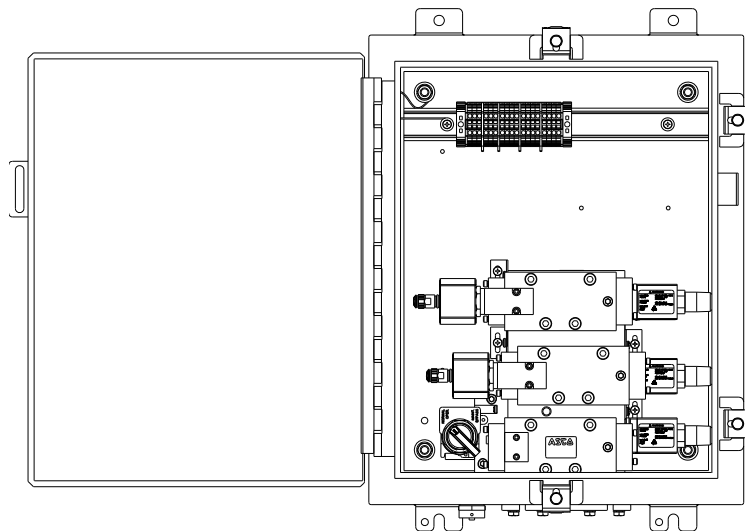

General Appearance of the 316L SST RCS  
(MEDIA: Instrument AIR Only)

Figure 1.

**HARDWARE**

For proper operation, a pneumatic pressure of 3-150 PSI must be supplied to the 316L SST RCS [process connection] while a pressure of 40-150 PSI must be supplied to the [pilot connection]. It is housed in a 20" x 16" x 8" enclosure. The primary components include:

- 316L stainless steel manifold body.
- Two low power (UL rated Class 1, Div. 2) solenoid-operated ISO-3 valves.

- A lever-actuated bypass valve.
- Three (UL rated Class 1, Div. 2 and ATEX rated Ex d IIC) pressure switches.
- An electrical terminal block for wiring termination (ATEX rated Ex e II)
- Associated wiring.

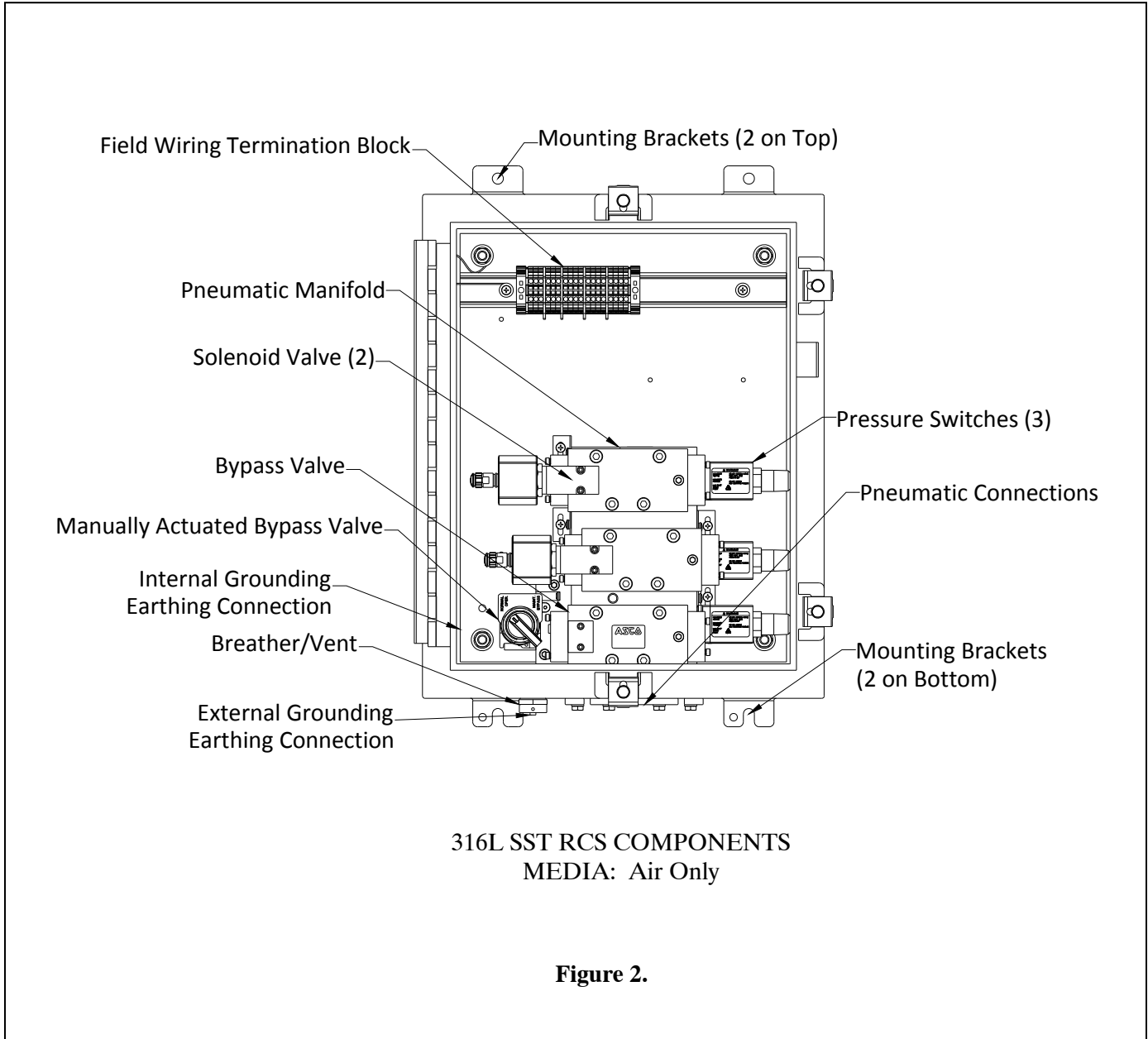

## SPECIFICATIONS:

### Solenoid Operator:

24 Volt DC low Power Explosion Proof Corrosion Resistant Non-Incendive Class F coil – 1.4 watts

24 Volt DC low Power Explosion Proof Corrosion Resistant Non-Incendive Class F coil – 1.8 watts

120/60-110/50 AC Explosion Proof Corrosion Resistant Class H coil – 10.1 watts

### Pneumatic Valve:

ISO-3; 5/2 air-spring valve; solenoid operated/Requires external pilot media supply.

### Bypass Valve:

ISO-3; 5/2 air-spring valve; manually operated/Requires external pilot media supply.

### Manifold:

3–station ISO base; unique pneumatic circuit design

### **Pressure Switches:**

3 each (UL rated Class 1, Div. 2, Groups A, B, C, D and ATEX rated Ex d IIC)

### Pressure Switch Type:

SPDT switches, hermetically sealed, 316L stainless steel.

### Switch Contact Rating:

Gold contacts(std) 1 amp suppressed resistive load; .5 amps inductive load @ 28 VDC.

### Connection & Setting:

¼” NPTF; 3 psi increasing/ 1 psi decreasing; non-adjustable.

### **Pneumatic Connections:**

#### Pilot:

1/8” NPTF

#### Pilot Pressure:

40- 150 psi

#### Inlet & Process:

1/2” NPTF

#### Exhaust Port:

1/2” NPTF

#### Process Pressure Range:

3 psi to 150 psi

#### Media Quality:

Instrument air per ANSI/ISA 7.0.01-1996 Particle size ≤ 40 microns.

### **Mechanical:**

#### Enclosure:

Electrical enclosure with hinged door.

#### Size:

20”x 16”x 8”

#### Weight:

Approximately 130 lbs.

### **Materials:**

#### Enclosure:

316L Stainless Steel

#### Mounting Panel:

316L Stainless Steel

#### Manifold:

316L Stainless Steel

#### Valves:

Body - 316L Stainless Steel, Sealing-Nitrile (NBR) or Fluorocarbon (FKM) and Spool and Sleeve Stainless Steel

Other – Acetal (POM) and Polyester-ether (TEEE)

#### Coil:

Epoxy encapsulated.

#### Pressure Switches:

316 Stainless Steel Wetted Surfaces

### **Environmental:**

#### Ambient temperature range:

Consult panel nameplate to verify.

RCS-R 1.4 watt (LT-NBR)= -40°F to 140°F (-40°C to 60°C)

RCS-R 1.8 watt (LT-NBR)= -40°F to 158°F (-40°C to 70°C)

RCS-R 1.4 watt (FKM)= 14°F to 140°F (-10°C to 60°C)

RCS-R 1.8 watt (FKM)= 14°F to 158°F (-10°C to 70°C)

RCS-R 10.1 watt (LT-NBR)= -13°F to 140°F (-25°C to 60°C)

RCS-R 10.1 watt (FKM)= 14°F to 140°F (-10°C to 60°C)

### **Component Certifications:**

#### Solenoid

24 Volt DC, 120/60-110/50 is UL & CSA certified for Class 1 & 2, Groups A, B, and C, D

#### Pressure Switches:

CSA approved and UL listed under “Industrial Control Equipment” ATEX rated Ex d IIC.

Name of Manufacturer

**ASCO<sup>®</sup>** REDUNDANT CONTROL SYSTEM  
ENCLOSURE TYPE 4, 4X, IP-66

MAX AMBIENT TEMP	POWER MAX.
MODEL NO.	VOLTAGE
SERIAL NUMBER/DATE	AIR, INLET (PSI)
	AIR, PILOT (PSI)

FLORHAM PARK, NEW JERSEY, USA

Electrical Parameters

Serial Number  
Including Date Code

Address of Manufacturer

**120/60-110/50 Applications**

Name of Manufacturer

**ASCO<sup>®</sup>** REDUNDANT CONTROL SYSTEM  
ENCLOSURE TYPE 4, 4X, IP-66

MAX AMBIENT TEMP	POWER MAX.
MODEL NO.	VOLTAGE
SERIAL NUMBER/DATE	AIR, INLET (PSI)
	AIR, PILOT (PSI)

FLORHAM PARK, NEW JERSEY, USA

Electrical Parameters

Serial Number  
Including Date Code

Address of Manufacturer

**24 Volt DC Applications**

**Figure 3. Nameplate Information**

## INSTALLATION

This section provides the information needed to install the 316L SST RCS.

### Unpacking:

Upon receipt of the 316L SST RCS, unpack it carefully and visually check for damage. The packing list shows the complete model number and describes the features of the unit.

1. If the unit is damaged, immediately contact ASCO.
2. If everything is in order, proceed to the instructions in the following sections.

### Mounting Location Considerations:

The 316L SST RCS is designed to be field mounted near the process valve to be actuated. The following factors should be considered when selecting a mounting location:

- **Accessibility:** Allow ample space for door operation, and for wiring and tubing runs.
- **Temperature:** Consider the amount of heat generated by equipment in the mounting area. The 316L SST RCS is intended for operation in ambient temperatures from - 40°F to 140°F (1.4 watts 24VDC LT-NBR), 14°F to 140°F (1.4 watts 24VDC FKM), - 40°F to 158°F (1.8 watts 24VDC LT-NBR), 14°F to 158°F (1.8 watts 24VDC FKM), -13°F to 140°F (120/60 AC LT-NBR), 14°F to 140°F (120/60 AC FKM).

**⚠ WARNING: Explosion Hazard! Do not remove or replace any component while circuit is live unless the area is known to be nonhazardous.**

ASCO components are intended to be used only within the technical characteristics as specified on the nameplate. Changes to the equipment are only allowed after consulting the manufacturer or its representative. Depending on the ambient/operation temperature heat resistant cabling capable for the temperature as indicated on the nameplate must be used.

### Mounting:

The 316L SST RCS is designed to be mounted vertically with pneumatic connections pointing down using the four mounting brackets provided on the enclosure corners as shown in Figure 4. It is recommended that four 3/8" or 10 mm diameter bolts be used.

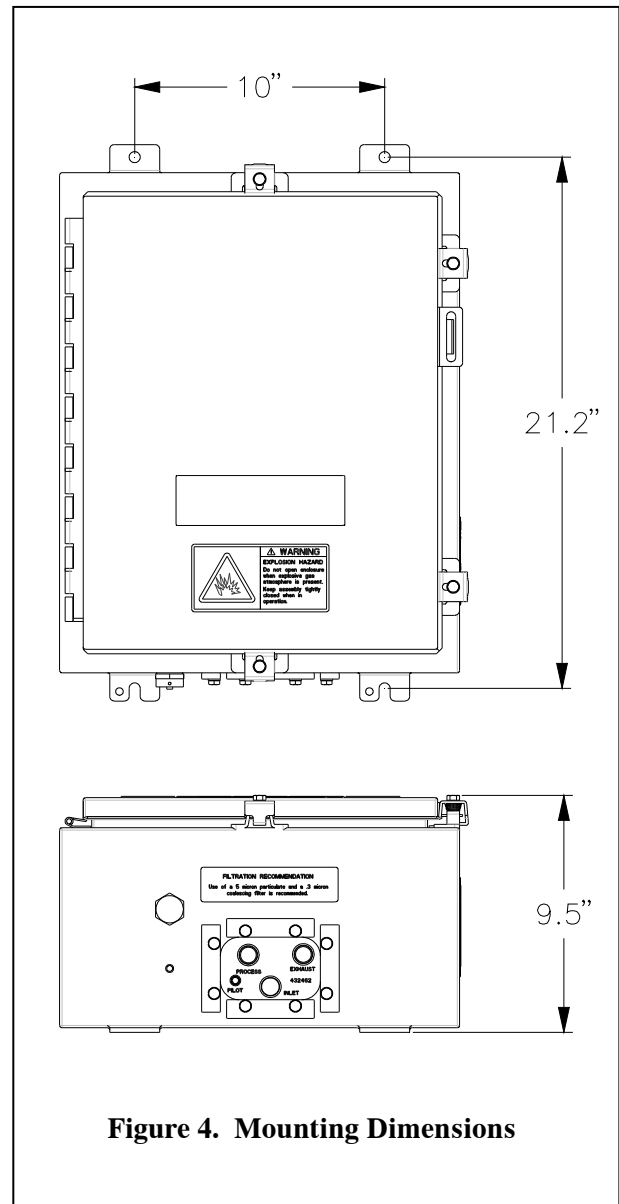

**Figure 4. Mounting Dimensions**

## Field Connections:

### Pneumatic Connections (Figure 5 A)

**⚠ WARNING: Explosion Hazard! Do not remove or replace any component while circuit is live unless the area is known to be nonhazardous.**

**⚠ CAUTION: Piping must comply with applicable local and national codes and ordinances.**

The 316L SST RCS should be mounted as closely to the process valve as possible. In order to insure proper operation of the process valve, tubing runs should be as straight and short as possible. Recommended piping for the inlet and outlet pneumatic connections to the 316L SST RCS is 1/2" stainless steel tubing. Recommended piping for pilot supply is 1/8" stainless steel tubing.

**IMPORTANT:** Do not install flow controls (speed or metering devices) or any type of restrictive device in the Inlet or Pilot (supply) ports or the Exhaust (outlet) port. Full size piping without restriction must be used. Restricting the piping may cause malfunction of the ISO-3 solenoid valves and/or bypass valve.

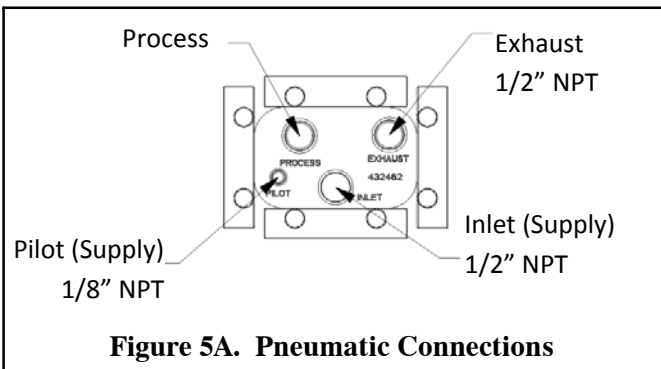

**Figure 5A. Pneumatic Connections**

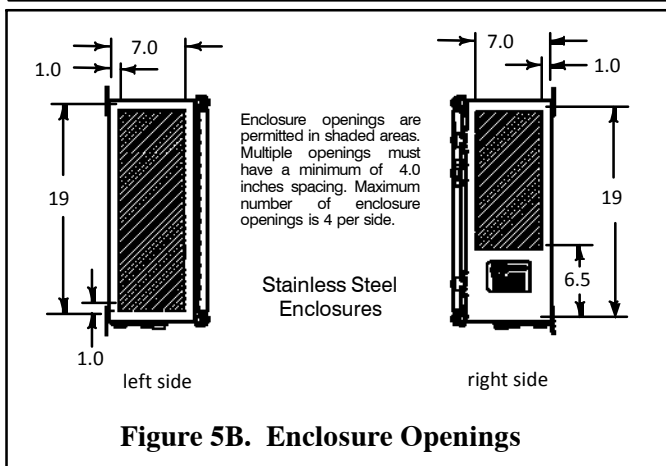

**Figure 5B. Enclosure Openings**

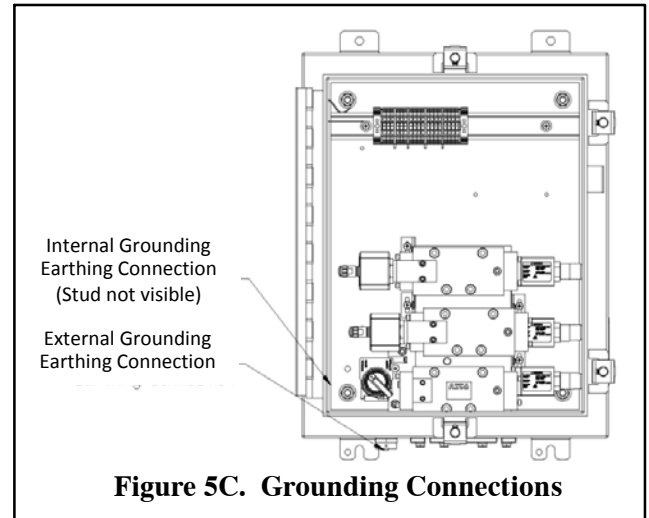

**Figure 5C. Grounding Connections**

## Wiring Guidelines

The following general guidelines apply to all wiring discussed in this document.

**⚠ WARNING: Circuit power must be removed from the device prior to disconnecting the wiring on either the field or internal side of the terminal strip.**

- Wiring shall be according to all applicable local and national codes.
- Wire size: stranded 16 and 18 AWG.
- The terminal clamps are designed for one wire only; DO NOT attempt to terminate multiple wires into one terminal.
- Use care when running signal wiring near to or crossing conduit or wiring that supplies power to motors, solenoids, lighting, horns, bells, etc.
- AC power wiring should be run in a separate conduit from DC power. All power wiring to and from the 316L SST RCS should be in grounded conduit.
- The 316L SST RCS should be connected to a high quality instrument grade ground with #14 AWG or heavier wire. A grounding stud is provided both inside and outside the enclosure.

## Electrical Connection (Customer Responsibility)

### General (Figure 5 B)

1. In all cases follow local and national electrical codes and requirements.
2. Placement of the conduit connection is up to the customer, in compliance with local and national requirements, based on location and ease of installation. The upper left or right side of the box will give the shortest run to the wire terminal.



3. Cable/conduit connections can be added in location as shown on Figure 5 B. Entry of external conductors and cables must be through properly installed and suitable certified flameproof cable entry devices and in accordance with local and national requirements. Assemble and install cable glands per manufacturer's instructions. Connect cable ground connections to the grounding/earthing terminal blocks or grounding earth studs provided internally and externally.
4. It is recommended that standard industry practices are followed to prevent condensation from entering the enclosure and, to prevent hazardous gases and vapors from migrating through the conduit to the control room or open ignition source.

**Grounding and Earthing.** (Figure 5 C)

Internal and external grounding studs are provided on the 316L SST RCS product. Ground/earth the product in accordance with local and national electric codes. Green earthing terminal blocks are provided for easy installation of conductor up to 4 mm sq.

Only insert one conductor per terminal block. Grounding studs are provided inside and outside of the enclosure for additional grounding/earthing requirements. (see Figure 5C)

**316L SST RCS-R Base Unit**

1. Connect the power source to the designated terminals (SOV1, SOV2) as per wiring diagram provided with the 316L SST RCS unit. Wiring diagrams are available on the Internet at: [www.ascovalve.com/rcsconfigurator](http://www.ascovalve.com/rcsconfigurator)
2. Wire the three pressure switches (PS1, PS2 & PS3) as per wiring diagram.
3. Wire optional accessories.
4. AC power wiring should be run in a separate conduit from DC power. All power wiring to and from the 316L SST RCS should be in grounded conduit.
5. The 316L SST RCS should be connected to a high quality instrument grade ground with #14 AWG or heavier wire. A grounding stud is provided both inside and outside the enclosure.

**Section 1.00 Normally Closed**

**1. General Operation**

The 316L SST RCS is a two-out-of-two (2oo2) or one-out-of-one hot standby (1oo1 HS) voting, solenoid-operated valve system designed for use as a component in safety instrumented systems. It functions as a redundant pneumatic tripping device to control the pilot media signal to a process valve actuator. Both solenoids must be de-energized (De-Energize-To-Trip Version) prior to moving the process to its fail-safe position.

Three pressure switches are included to provide indication of each solenoid-operated valve and bypass valve position.

The 316L SST RCS allows for periodic testing of the solenoids by cycling one solenoid valve and then the other either manually (when ordered with a local initiation of SOV test option) or automatically (by the system DCS) therefore maintaining the desired safety availability. This testing is performed online without the need for bypassing of the safety action and without interruption of the system process.

Under normal operating conditions, the 316L SST RCS supplies pilot media to the process valve actuator through the "process" port. When a trip occurs, the 316L SST RCS blocks the incoming pneumatic signal and connects the "process" port to the "exhaust" port. This vents the media signal from the process valve actuator and allows the actuator return spring to move the process to its fail-safe position.

**The pressure switches report solenoid valve positions as follows: RUN MODE:**

- De-Energize-To-Trip:(Figure3a and 3b)  
If solenoid valve #1 (resp. #2) is in the energized position, the contact of pressure switch #1 (resp. #2) is open. Pressure vents from pressure switch #1 (resp #2). Pressure is applied to pressure switch #3 and contact closed.

**BYPASS MODE:**

- The manually operated maintenance bypass valve is used to isolate and depressurize the solenoid valves and pressure switches during maintenance. The maintenance bypass valve position is indicated by pressure switch #3.
- In the Bypass mode, the 316L SST RCS "inlet" port is directly connected to the "process" port. The solenoid valves and pressure switches are vented to "exhaust".
- In the Bypass mode, the contacts of pressure switches #1, #2 and #3 are open which indicates that no pressure is on the solenoid operated valve or pressure switches.

**Manually-Actuated maintenance bypass valve operation:**

The manually-actuated bypass valve has two positions: **NORMAL** for system run and **MAINTENANCE BYPASS** for maintenance of the solenoid valves and pressure switches. To change positions simply rotate the lever to the desired position indicated on the switch face plate.

**Status of SOVs Pressure Switches indicated as shown**

Solenoid Valves	Pressure Switch 1	Pressure Switch 2	Pressure Switch 3
Both SOVs Energized	O	O	CL
Both SOVs De-Energized	CL	CL	CL
SOV 1 De-Energized Only	CL	O	CL
SOV 2 De-Energized Only	O	CL	CL
<b>Bypass Mode</b>	<b>O</b>	<b>O</b>	<b>O</b>

CL = Pressure switch Normally Open contact is Closed

O = Pressure switch Normally Open contact is Open

**Figure 3a.** Test Table of Solenoid Valve Status

(Normally Closed, De-Energize-To-Trip)

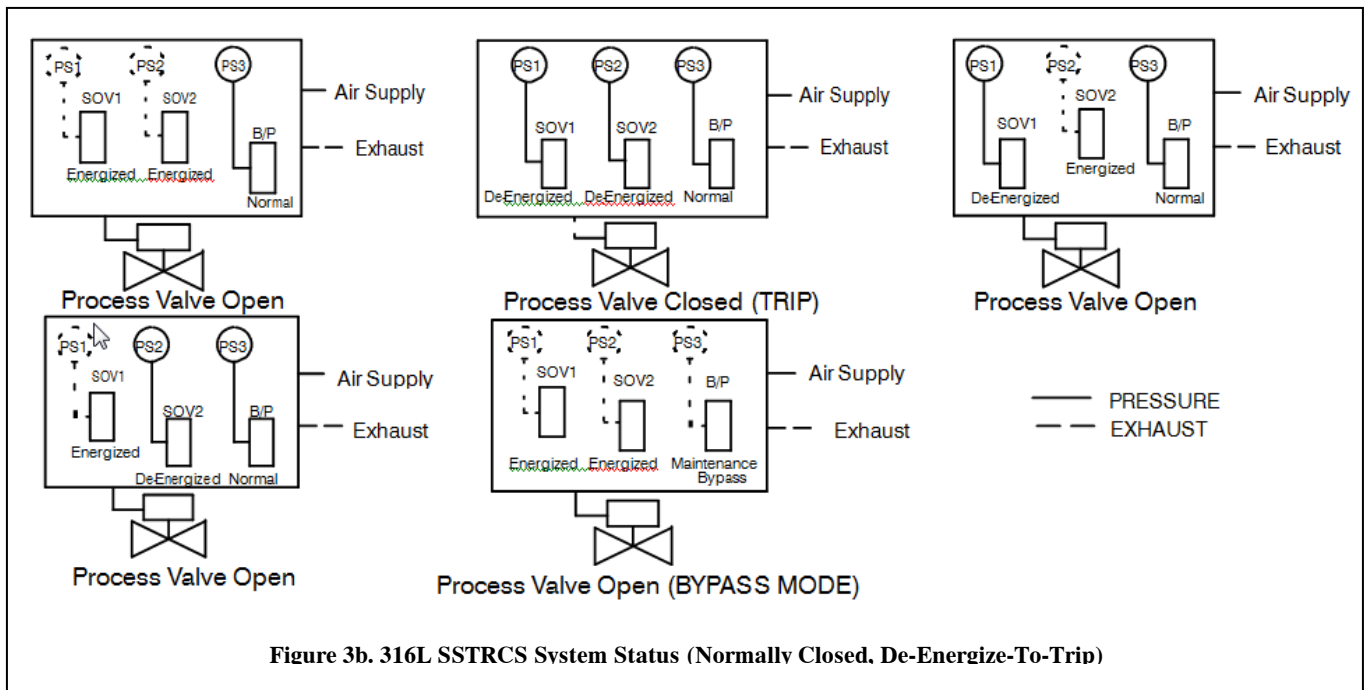

Figure 3b. 316L SSTRCS System Status (Normally Closed, De-Energize-To-Trip)

### Pressure Switches

The pressure switches are factory set to actuate at 3 psig -increasing and 1 psig decreasing pressure. The pressure switches are fixed and not adjustable.

## 2. Testing and Maintenance:

### Testing:

#### Solenoid-operated valve testing

The solenoid-operated valves and their associated pressure switches can be tested online without interruption of the process. This testing is implemented by cycling each solenoid-operated valve and comparing the associated pressure switch contact reading to the test table (see Figure 3a).

#### Partial Stroke testing

A partial stroke of the process valve can be performed online without interruption of the process. This testing is implemented by performing solenoid-operated valve testing, then moving the process valve toward the safe state for a predetermined time. At the end of the predetermined time, the process valve is returned to the normal position.

Testing can be automated using a programmable logic controller (PLC) or a distributed control system (DCS).

**⚠ CAUTION: (De-Energize-To-Trip Version) De-energizing two solenoid valves at the same time will initiate a shutdown.**

1. At all times during testing, one out of the two solenoid-operated valves must be in the energized position (De-Energize-To-Trip Version).
2. IF, during the test process, the pressure switches do not indicate what is expected according to the test table (see Figure 3a), the second solenoid-operated valve must not be de-energized.

### Maintenance:

The Pneumatic 316L SST RCS requires no routine maintenance except periodic inspections for loose wires and fittings. The enclosure should be opened occasionally and the components checked to make sure they are tight, clean, and dry. The Breather/Vent valve shall be inspected for obstruction and that it is free of debris during routine maintenance cycles and during manual proof testing.

### Manually-Actuated Bypass Valve

If it is necessary to replace a solenoid-operated valve or pressure switch during normal operation, the manually-operated bypass valve is used.

This valve is used to isolate and depressurize the solenoid valves and pressure switches for maintenance only.

When the switch is rotated to the bypass position, the 316L SST RCS manifold channels the inlet pressure directly to the process port. Pressure to the solenoid valves and pressure switches are vented to “exhaust”. Contacts to pressure switches #1, #2, and #3 are open which signals the DCS that the 316L SST RCS is in bypass and not in shut down.

### Manual Bypass Valve Operation (for maintenance only)

**⚠ WARNING: Explosion Hazard. Do not open the enclosure unless area is known to be non-hazardous.**

1. Turn the lever clockwise from “Normal” to “Maintenance Bypass”. The system pressure is now bypassed directly from “inlet” to “process” so that the process valve position is maintained.
2. Verify that all 3 pressure switch contacts are open, indicating the 316L SST RCS is in Bypass.

**⚠ WARNING: Explosion Hazard. Do not remove or replace any component while circuit is live unless area is known to be non-hazardous.**

3. Turn off power to the 316L SST RCS; disconnect appropriate wires from terminal block.
4. Remove device (coil, solenoid valve, or pressure switch) and install the new device following instructions supplied. If replacing a solenoid valve, apply a small amount of anti-seize to the bolt threads and torque to 160-175 in-lbs in a crisscross pattern. Reconnect wires to appropriate terminal, (see wiring diagrams).
5. Turn on power to the 316L SST RCS. Verify that each device has power and is in the correct state. (see Figure 3a).
6. Rotate lever counter clockwise to the “normal” position.
7. Perform a leak check on any new/replaced device using seam test around its pipe connections and/or mating surfaces using a soapy solution or a commercially available leak detecting solution. If bubbles appear

disassemble clean mating surfaces and/or apply thread sealant.

**IMPORTANT: Be sure to check for leakage in both Energized and De-energized state.**

8. Have the control room run through the programmed test to be sure the system is operating properly.

## **Section 2.00**

### **1. Functional Test Certification**

Once assembled and inspected the 316L SST RCS is cycled through a generic program to validate two-out-of-two (2oo2) or one-out-of-one hot standby (1oo1 HS); shut down function; partial stroke function; solenoid valve status and pressure switch indication table; manual bypass function.

### **2. Spare Parts**

**⚠ WARNING: Replacement parts are only to be obtained from ASCO or an authorized distributor or the certifications may be invalidated or there may be a risk of explosion.**

## **SPARE PARTS**

<b>VALVES AND COILS</b>					
<b>APPLICATION</b>	<b>VOLTAGE</b>	<b>ELASTOMER</b>	<b>EXHAUST ASSY</b>	<b>VALVE KIT</b>	<b>COIL</b>
De-Energize-To-Trip	24/DC 1.4 watts	FKM	NO	325577	274714-902-D
	24/DC 1.4 watts	LTNBR	NO	325578	274714-902-D
De-Energize-To-Trip	24/DC 1.8 watts	FKM	NO	325579	274714-905-D
	24/DC 1.8 watts	LTNBR	NO	325580	274714-905-D
De-Energize-To-Trip	120/60-110/50	FKM	NO	325581	274814-032-D
	120/60-110/50	LTNBR	NO	325582	274814-032-D
Bypass	ALL	FKM	n/a	325583	n/a
	ALL	LTNBR	n/a	325584	n/a

<b>RCS BYPASS LEVER SWITCHS</b>		
RCS BYPASS LEVER SWITCHS	FKM	325569
RCS BYPASS LEVER SWITCHS	LTNBR	325570

<b>PRESSURE SWITCHS</b>		
Pressure Switch SPDT Gold Contacts	FKM	325571
Pressure Switch SPDT Gold Contacts	LTNBR	325572

### 3. Packaging

While the package for 316L SST RCS is designed to handle the weight of the unit, there are always hazards in shipping. Upon receipt of product, unpack and check the product against the packing slip. If there is damage to the product, immediately contact the Authorized ASCO sales representative.

### 4. Limited Warranty

**WARRANTIES:** The manufacturer warrants its products and equipment to be free from defects in material and workmanship for a period of one year from the date of shipment from its factory.

The Manufacturer is not responsible for damage to its products through normal wear and tear, improper installation, maintenance, use, repairs or adjustment, or attempts to operate it above its rated capacity or voltage, intentional or otherwise, or for unauthorized repairs. To the extent the Manufacturer has relied upon specifications, information, representation of operating conditions or other are supplied by Buyer or its agents to Seller in the selection or design of the goods, and the operation conditions or other conditions differ from those represented by the Buyer and relied upon by Manufacture, and warranties or other provisions contained herein which are affected by such conditions shall be null and void.

NO OTHER REPRESENTATION, GUARANTEES OR WARRANTIES, EXPRESSED OR IMPLIED, ARE MADE BY THE MANUFACTURER AND THE FOREGOING WARRANTY IS IN LIEU OF ALL OTHER REPRESENTATIONS AND WARRANTIES, EXPRESSED OR IMPLIED, WHICH ARE HEREBY EXPRESSLY DISCLAIMED AND WAIVED BY BUYER, INCLUDING ANY WARRANTY OF

MERCHANTABILITY OR OF FITNESS FOR PARTICULAR PURPOSE, WHETHER OR NOT THE PURPOSE OR USE HAS BEEN DISCLOSED TO SELLER IN SPECIFICATION, DRAWING OR OTHERWISE, AND WHETHER OR NOT THE PRODUCT IS SPECIFICALLY DESIGNED AND/OR MANUFACTURED FOR BUYERS USE OF PURPOSE.

### Disclaimer

Because of the variety of uses for the ASCO 316L Stainless Steel Redundant Control System (316L SST RCS), the user and those responsible for applying this equipment must satisfy themselves as to the acceptability of the 316L SST RCS for each application.

The illustrations in this manual are solely intended to illustrate the text of this manual. Because of the many variables and requirements associated with this particular installation, ASCO cannot assume responsibility or liability for actual use based upon the illustrative uses and applications.

In no event will ASCO be responsible or liable for indirect or consequential damages resulting from the use or application of this equipment. ASCO disclaims any implied warranties of merchantability or fitness for a particular purpose.

**ASCO DISCLAIMS ANY IMPLIED WARRANTY OR FITNESS FOR A PARTICULAR PURPOSE.**

No patent or copyright liability is assumed by ASCO with respect to use of information, circuits, equipment or software described in this text.

Reproduction of the content of this manual, in whole or in part, without written permission from ASCO is prohibited.

## **Tools Required for Routine Service of RCS**

**Multi-meter**

**3mm Hex Key**

**6mm Hex Key**

**1/4" Hex Key**

**3/16" Hex Key**

**Large and Small Slotted Screwdriver**

**Large and Small Phillips Screwdriver**

**Wire cutter/stripper**

**7/16" Open end wrench**

**1/2" Open end wrench**

**9/16" Open end wrench**

**1" Open wrench**

**1 1/8" Open wrench**

**1 1/2" Open end wrench**

**16mm open end wrench**

## **RCS- R Wiring Diagram (A)**

OUTSIDE OF FRONT PANEL

CUSTOMER /FIELD WIRING LOCATION

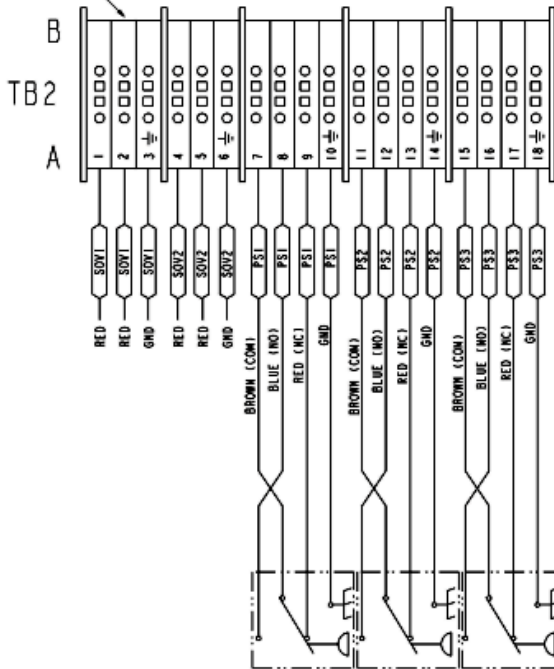

NOTICE: CUSTOMER WIRING RELATIVE TO PRESSURE SWITCHES

1. DETERMINE PNEUMATIC OPERATION (NORMALLY CLOSED).
2. REFER TO THE TABLES BELOW TO DETERMINE THE PRESSURE SWITCH 1 (PS 1) TERMINAL STATIONS MATCHING THE PNEUMATIC OPERATION.
3. CONNECT CORRESPONDING TERMINAL STATIONS TO THE DIGITAL CONTROL SYSTEM.
4. REPEAT STEPS 2 & 3 FOR (PS 2) AND (PS 3).

STANDARD WIRING CONFIGURATION

	PS1	PS2	PS3
NORMALLY CLOSED	7-BROWN (COM)	11-BROWN (COM)	15-BROWN (COM)
	8-BLUE (NO)	12-BLUE (NO)	16-BLUE (NO)
	10-GROUND	14-GROUND	18-GROUND

ALTERNATIVE WIRING CONFIGURATION  
REVERSE PRESSURE SWITCH LOGIC REQUIRED  
(CONTACT TECHNICAL SALES)

	PS1	PS2	PS3
NORMALLY CLOSED	7-BROWN (COM)	11-BROWN (COM)	15-BROWN (COM)
	9-RED (NC)	13-RED (NC)	17-RED (NC)
	10-GROUND	14-GROUND	18-GROUND

WIRE RUN LIST

WIRE #	CONNECTIONS	COLOR	LENGTH
1	TB2A01	SOV1	RED
2	TB2A02	SOV1	RED
3	TB2A03	SOV1	GREEN
4	TB2A04	SOV2	RED
5	TB2A05	SOV2	RED
6	TB2A06	SOV2	GREEN
7	TB2A07	PS1	BROWN (COM)
8	TB2A08	PS1	BLUE (NO)
9	TB2A09	PS1	RED (NC)
10	TB2A10	PS1	GREEN
11	TB2A11	PS2	BROWN (COM)
12	TB2A12	PS2	BLUE (NO)
13	TB2A13	PS2	RED (NC)
14	TB2A14	PS2	GREEN
15	TB2A15	PS3	BROWN (COM)
16	TB2A16	PS3	BLUE (NO)
17	TB2A17	PS3	RED (NC)
18	TB2A18	PS3	GREEN

OPTION	DESCRIPTION	DRAWING #
A	---	---
B	LOCAL INDICATION OF BYPASS	500229
C	LOCAL INITIATION OF PARTIAL STROKE TEST	500231
D	LOCAL INITIATION OF SOV TEST	500230
K	SYSTEM STATUS (COMMON ALARM)	500228
R	ONE OPTIONAL LIGHT	287729
S	TWO OPTIONAL LIGHTS	288004
T	ONE OPTIONAL PUSHBUTTON	288005
U	TWO OPTIONAL PUSHBUTTONS	288006
V	THREE OPTIONAL PUSHBUTTONS	291940
W	FOUR OPTIONAL PUSHBUTTONS	291941
Y	THREE OPTIONAL LIGHTS	291976
Z	FOUR OPTIONAL LIGHTS	291977
NONE	BASE WIRING - NO OPTIONS	500223

WIRE	COLOR
070525-018-LW1	BLACK
070525-018-LW5	RED
070525-018-LW2	GREEN
070525-018-LW7	BLUE

NOTE:  
1. FOR 5R STANDARD UNIT BASE WIRING SEE 28708A.

<p>UNLESS OTHERWISE SPECIFIED, ALL WORK IS TO BE ACCORDING TO THE ASCO VALVE COMPANY WIRING MANUAL, 1997 EDITION, REV. 10/97.</p>		<p>DATE: 10/10/03</p>	
<p>WIRING PCS ON CLAMP UNIT ONLY BASE WIRING - NO OPTIONS</p>		<p>PRO/ENGINEER: [Signature]</p>	
<p>DATE: 10/10/03</p>		<p>SCALE: A1</p>	
<p>LOCATION: [Blank]</p>		<p>500223</p>	

## RCS NORMALLY CLOSED PIPING DIAGRAMS

RCS used as 3-way NC pilot valve with 40-150 psi instrument air supply required

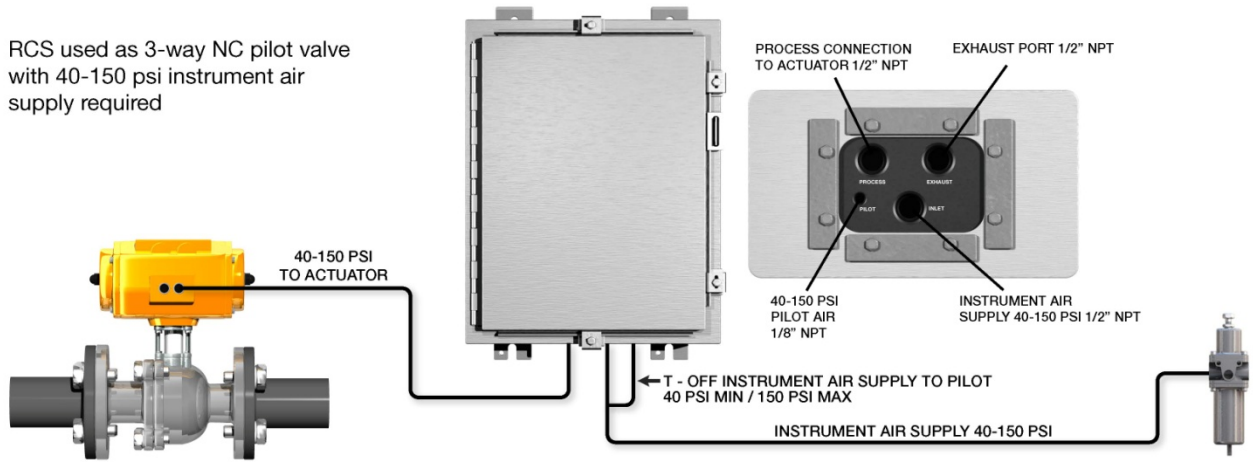

RCS used as 3-way NC pilot valve with 3-150 psi instrument air supply required

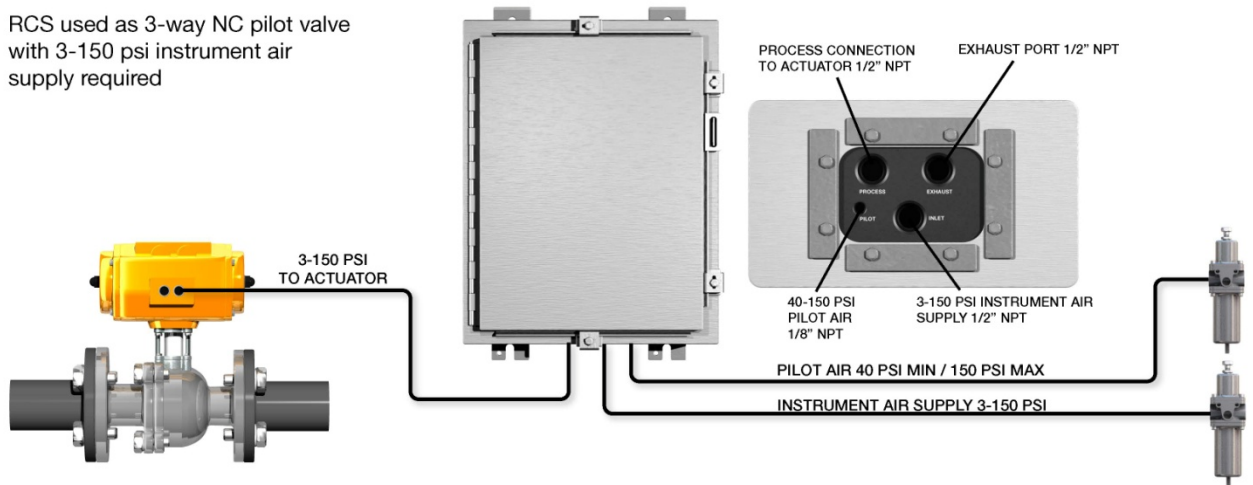

RCS used as 3-way NC pilot valve with valve controller

