

# INSTALLATION, OPERATION AND MAINTENANCE INSTRUCTIONS FOR FAIRCHILD MODEL 21 ADJUSTABLE RATIO RELAY

## GENERAL INFORMATION

The Model 21 adjustable ratio relay provides an outlet pressure with a high volume of flow which is a reproduction of the signal pressure multiplied by the ratio.

### Specifications Model 21

Flow ..... 40 SCFM (68 m<sup>3</sup>/HR)  
 Exhaust capacity ..... 5½ SCFM (9.4 m<sup>3</sup>/HR)  
 (Downstream pressure 5 psig  
 [.35 BAR] (35 kPa) above set pressure)  
 Sensitivity ..... 0.5" (1.27 cm) W.C

Effect of supply  
 pressure variation ..... less than 0.1 psig [.007 BAR]  
 (.7 kPa) for 100 psig [7.0 BAR]  
 (700 kPa) change

Maximum supply pressure ..... 250 psig  
 [17.0 BAR] (1700 kPa)

Maximum signal or output pressure ..... 150 psig  
 [10.0 BAR] (1000 kPa)

Ratio range ..... 30:1 thru 1:30  
 (First number indicates signal pressure, second  
 number indicates output pressure)

## PRINCIPLES OF OPERATION

The Model 21 consists of a signal chamber lever arm, a Model 20 output valve body and pivot assembly for lever arm adjustment. The ratio of output pressure to signal pressure is infinitely adjustable. Signal adjustment range permits signal amplification of 1:30 or signal reduction of 30:1 by rotation of the ratio adjustment knob. An infinite number of ratios can be obtained within the limitation of the relay.

The signal pressure acting on the signal chamber diaphragm transmits a force through a lever to the control diaphragm and thus sets output pressure. The lever fulcrum is adjustable.

Output pressure is a function of signal pressure times the ratio of lever arm lengths on either side of the fulcrum.

The signal pressure performs the function of the range spring in a pressure regulator. The signal acts against the piston and diaphragm which exert a force against the lever arm. The lever arm pivots about the pivot assembly to exert a force against the control diaphragm assembly. The diaphragm assembly is a high strength, deep convolution balance diaphragm. Force exerted against the diaphragm assembly acts to open the inner valve and allow inlet pressure at a high flow rate at the outlet port and control chamber exerting a balance force against the signal. A floating seal ring isolates the control chamber and increases stability by reducing the effect of high flows.

A bias can be introduced by means of the set screws.

The Model 21D is available with both input and output adjustable bias. Maximum input bias is 3 psi. Maximum output bias is 9 psi. The basic mathematical expression for the bias in this relay is:

$$P_o = (P_s - K_1) R + K_2$$

- P<sub>o</sub> = Output Pressure
- P<sub>s</sub> = Input Signal
- R = Ratio of Setting
- K<sub>1</sub> = Input Bias (-) Only
- K<sub>2</sub> = Output Bias (+) Only

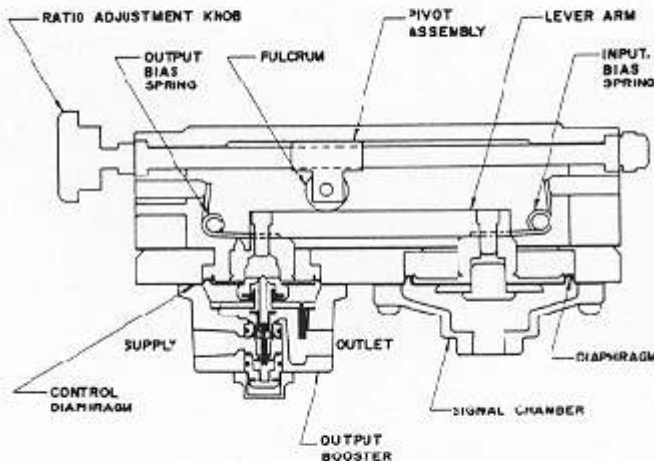

Figure 1

## INSTALLATION

Clean all lines to remove dirt and scale before installation is made. Apply minimum amount of pipe compound to male threads of air line only. Start with third thread back and work away from end of line to avoid possibility of getting compound into air lines.

Install relay; the unit should be mounted in the horizontal position for best operation. The  $\frac{1}{4}$ " or  $\frac{3}{8}$ " NPT inlet and outlet connections are labelled; look for arrows denoting direction of flow through the booster on the underside of the unit. The signal line is tapped  $\frac{1}{4}$ " NPT connection. All connections should be securely tightened. Avoid undersized fittings that will limit flow

through the relay.

The use of a filter to remove dirt and entrained liquid in the air line ahead of the relay is recommended for best performance. If an air line lubricator is used, it should be located downstream beyond the relay in order to avoid interference with performance.

### NOTICE

The presence of certain ester oils in airlines may hasten deterioration of the elastomers and thus decrease the useful life of this unit.

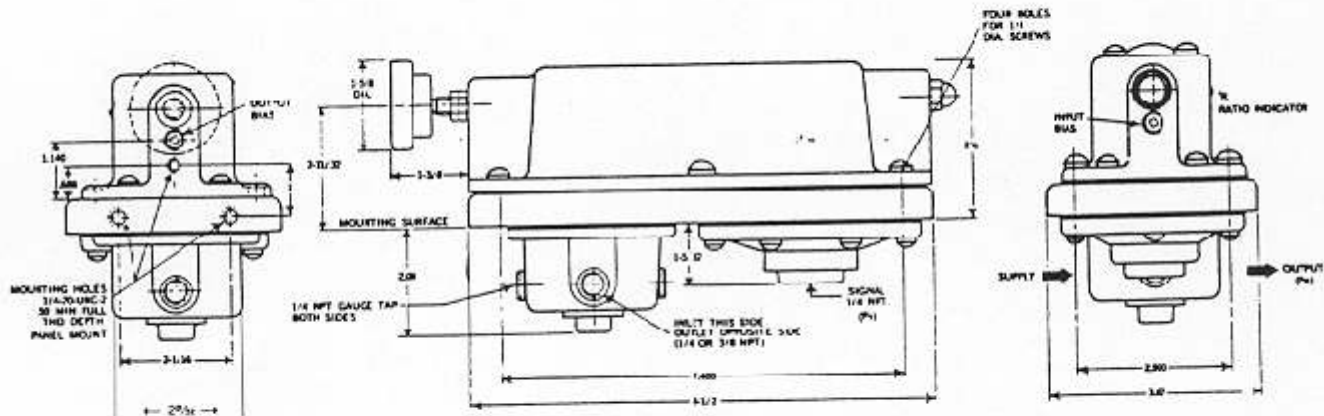

## SERVICE KIT INSTALLATION

1. Check the parts in the EA-12132 service kit against the parts marked with an asterisk in the exploded view and the associated table.
2. Remove six Screws (1) attaching cover assembly of Model 21 (2) to Base (3).
3. Remove Cover Assembly (2) and set aside.
4. Remove Spacers (4) and set aside.
5. Remove two Screws (5) holding Lever Arm (6) to Valve End Spacer (7) and Signal End Spacer (8). Set lever arm and screws aside.
6. Remove six Screws (9) holding Signal Chamber (24) to the Model 21 Base (3).
7. Remove Model 21 Base (3).
8. Remove six Screws (11) holding the Model 20 Body Assembly (12) to Model 21 Base (3). Mark both Body Assembly (12) and Base (3) so that they can be re-assembled in the same position.
9. Remove Body Assembly (12) from Base (3) by tapping it lightly with a rubber or rawhide mallet.
10. Remove two Screws (13) holding Retainer Cap (14) to Body Assembly (12). Remove Retainer Cap (14) and Cartridge Retainer (15) and set aside.
11. Remove Diaphragm Assembly (16) from Model 20 Body Assembly (12) and set aside.
12. Tap inner Valve Assembly (17) gently with a rubber mallet to drive it out of Body (18).
13. Remove four Screws (19) holding Seal Plate (20) to Body (18). Set the screws and seal plate aside.
14. Remove Gasket (21) from Body (18).
15. Using rubber mallet, drive out Seat Assembly (22).
16. Secure Seat Assembly (22) from kit and insert into bottom of Body (18), brass end first, until it is seated against the body shoulder.
17. Secure inner Valve Assembly (17) and Screen (17A) from kit. Assemble screen to inner valve assembly and insert into Body (18), pintle first from bottom end until brass shoulder is flush with the bottom. Replace the Cartridge Retainer (15) and Retainer Cap (14) set aside in step 10. Insert two Screws (13) and tighten.
18. Secure Gasket (21) from kit and place in Body (18), aligning holes in gasket with holes in body.
19. Place Seal Plate (20) removed in Step 11 over Gasket (21) making sure that aspirator tube is in the chamber next to the OUT port. Insert four Screws (19) and tighten alternately until snug.

Item	Part No.	Description
1	EE-8603	Screw
2	EE-9877-2	Cover Assembly
3	EE-10630	Base
4	EE-9705	Spacer
5	EE-9673-4	Screw
6	EE-9682	Lever Arm
7	EE-9663-4	Spacer-Valve End
8	EE-9663-3	Spacer-Signal End
9	EB-1032-12	Screw
11	EB-1032-12	Screw
12	EB-1861	Body Assembly
13	EB-1036-2	Screw
14	EB-7136	Retainer Cap
15	EB-6027	Cartridge Retainer
*16	EB-9679-1	Diaphragm Assembly
*17	EB-1820-3	Inner Valve Assembly
*17A	EB-6017	Screen
18	EB-6050	Body
19	EB-1032-5	Screw
20	EB-7036	Seal Plate Assembly
*21	EB-6053	Gasket
*22	EB-9047	Seat Assembly
*23	EB-9678	Daphragm Assembly
24	EB-4605	Signal Chamber

\*EB-12132 Kit Components

20. Position body assembly (12) so that the IN port is facing the viewer. Secure diaphragm assembly (16) from kit, and position diaphragm so that spring retainer cutout is to the left. Insert seal on diaphragm over seal tube on seal plate (20), gently.

**NOTE: Assure that seal in diaphragm assembly is not pulled out of diaphragm assembly, making the seal ineffective.**

21. Align mark on body (12) made in step 8 with mark on baseplate (3). Insert six screws removed in step 8 and alternately tighten screws to fasten body (12) to baseplate (3).

22. Remove diaphragm assembly (23) from baseplate (3) and replace with assembly from service kit, making sure that holes in the diaphragm assembly are aligned with holes in the mounting plate.

23. Using six screws (9) removed in step 6, reassemble diaphragm assembly (23) and signal chamber (24) to baseplate. Screws are inserted from the underside of the mounting plate and should be tightened alternately to prevent warping of the plate.

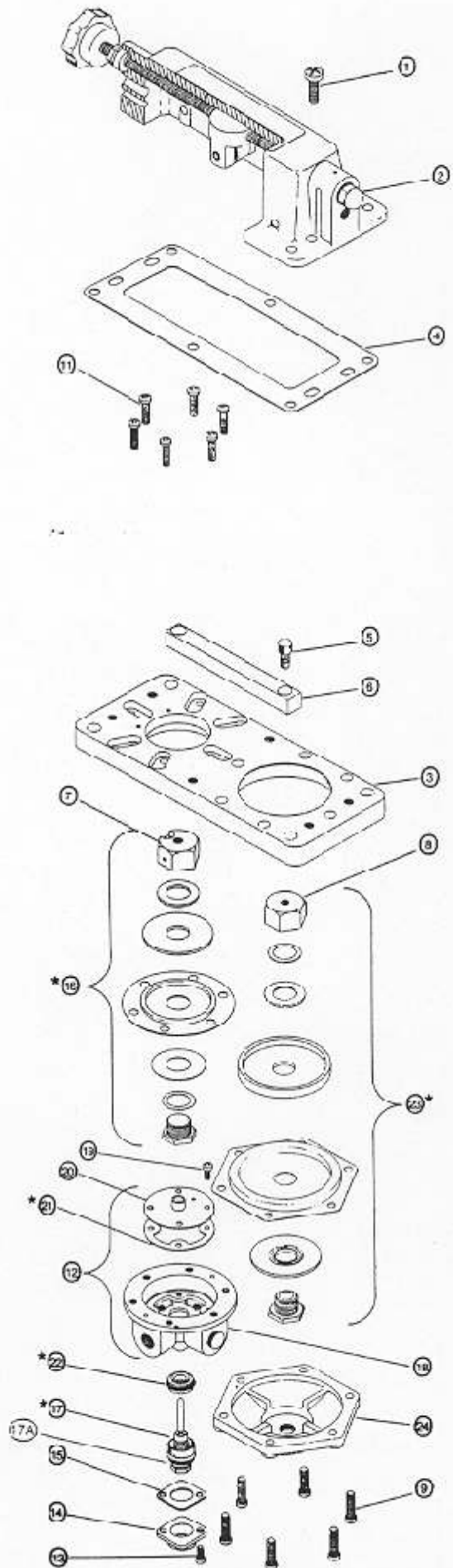

24. Place lever arm (6) across valve end (7) and signal end (8) spacers (counterbored hole closest to end of lever arm over valve end spacer) and fasten to the spacers with two screws (5).
25. Replace spacers (4) set aside in step 3 and align with holes in the mounting plate (10).
26. Place cover assembly (2) set aside in step 2 over base (3) making sure that knob end of cover is positioned over the valve end of the Model 21 Baseplate (3). Insert six screws (1).

**NOTE: The cover assembly will have to be positioned so that the dual bias springs straddle the lever arm.**

27. Alternately tighten the screws (1) attaching the cover assembly (2) to base (3).
28. Reinstall the relay in accord with the installation instructions in the IOM and follow instructions in the Operation section for placing the transducer back in service.

### ADJUSTMENTS

**Bias Adjustment.** Set ratio at 1:1 as indicated on the indicator. Back out both bias adjusting screws (63) (at either end of the unit) apply supply pressure to the relay. Turn clockwise bias screw to the output end, until the desired bias is reached (do not exceed 9 psi). Note the output pressure of the unit. Apply 10 psi signal to the signal port. Note the output pressure of

the unit. Output should only increase by 10 psi. (If not, adjust the ratio until the output reads 10 psi, increase.) Now, adjust (clockwise) input bias adjusting screw until the output is decreased by the exact amount of input bias desired. The unit is now set for the correct input and output bias.

### OPERATION

Use the ratio knob to adjust the ratio to any desired setting. Clockwise rotation of the knob will decrease the ratio of output pressure to input pressure.

### MAINTENANCE

The relay is easily disassembled for the occasional cleaning or removal of foreign matter. Before this is done however, shut down valve upstream of the relay to prevent escape of air when the relay is disassembled. There is no need to remove the instrument

from the line; merely removing the two No. 10-32 screws is all that is required. Wash inner valve assembly with solvent exercising care to avoid damaging diaphragms and valve facings. Replace assembly.

### TROUBLE SHOOTING

PROBLEM	CHECK
High Bleed Rate	Relief seat for out of round inner valve
Leakage	Diaphragm

### REPAIR PARTS LIST

Service Kit (EA-12132) is available for the Model 21 Relay.

### LEGAL NOTICE:

The information set forth in the foregoing Installation, Operation and Maintenance Instructions shall not be modified or amended in any respect without prior written consent of Fairchild Industrial Products Company. In addition, the information set forth herein shall be furnished with each product sold incorporating Fairchild's unit as

ISO 9001:2000  
Certified

  
**FAIRCHILD**  
INDUSTRIAL PRODUCTS COMPANY  
3920 WESTPOINT BLVD. WINSTON-SALEM, NC 27103-6708  
TEL 336-659-3400 FAX 336-659-9323

[www.fairchildproducts.com](http://www.fairchildproducts.com)



ISO 9001:2000  
FM NO. 25571

IS- 3000021  
Litho in USA  
Rev. F 08/03