



Fabricast Valve Company
1061 Industrial Way, Longview, WA 98632
Toll-Free 1-877-264-2503
Local (360) 425-0306 **Fax** (360) 425-0353
www.knifegates.com
sales@fabricastvalve.com

FIG 40-50-61

LEVER OPERATOR

FIG 40-50-61

Fabricast Valve

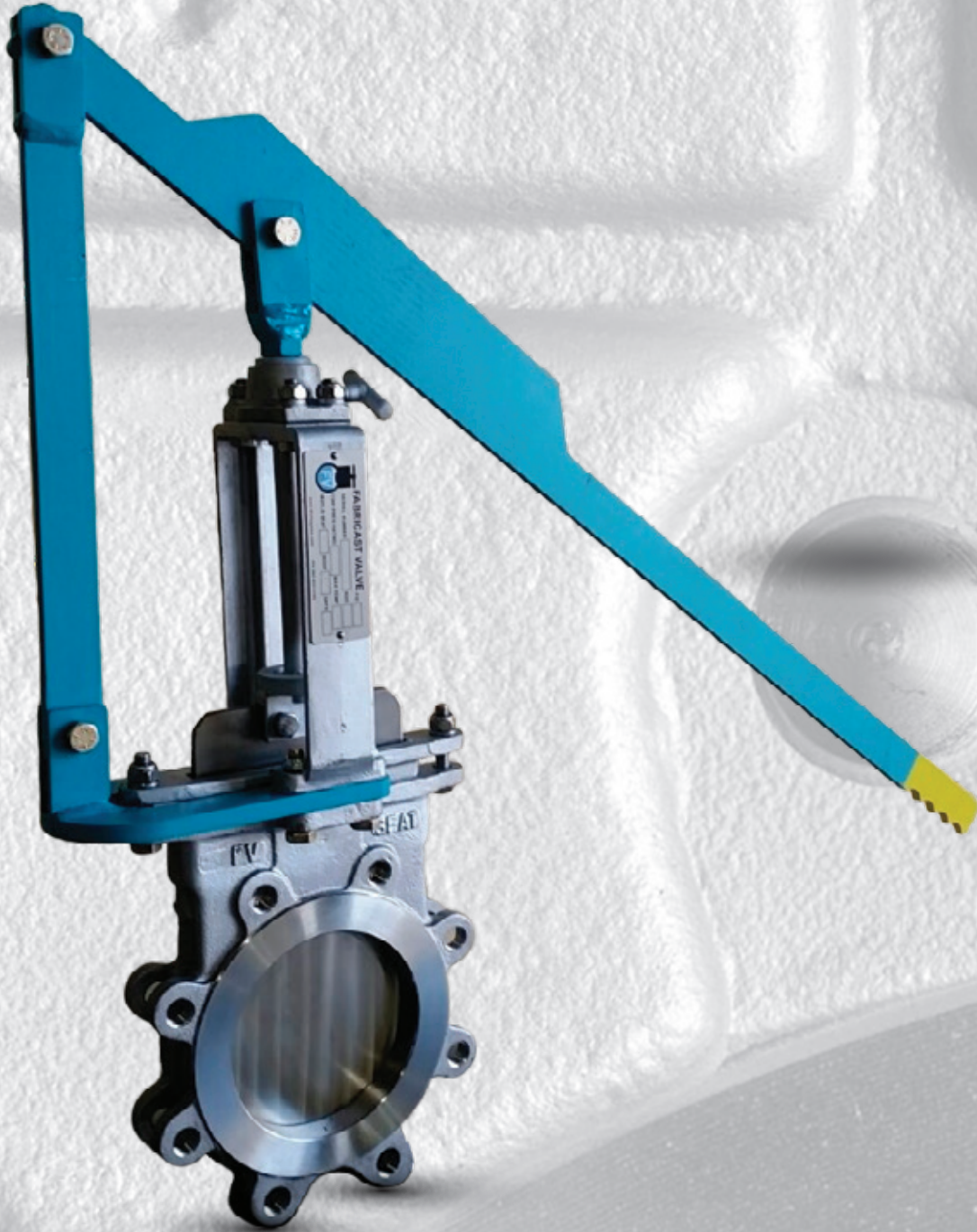



Fabricast Valve Company

1061 Industrial Way

Longview, WA 98632

toll free 1-877-264-2503 phone (360) 425-0306

fax (360) 425-0353 www.knifegates.com

FIG 40-50-61

LEVER OPERATOR

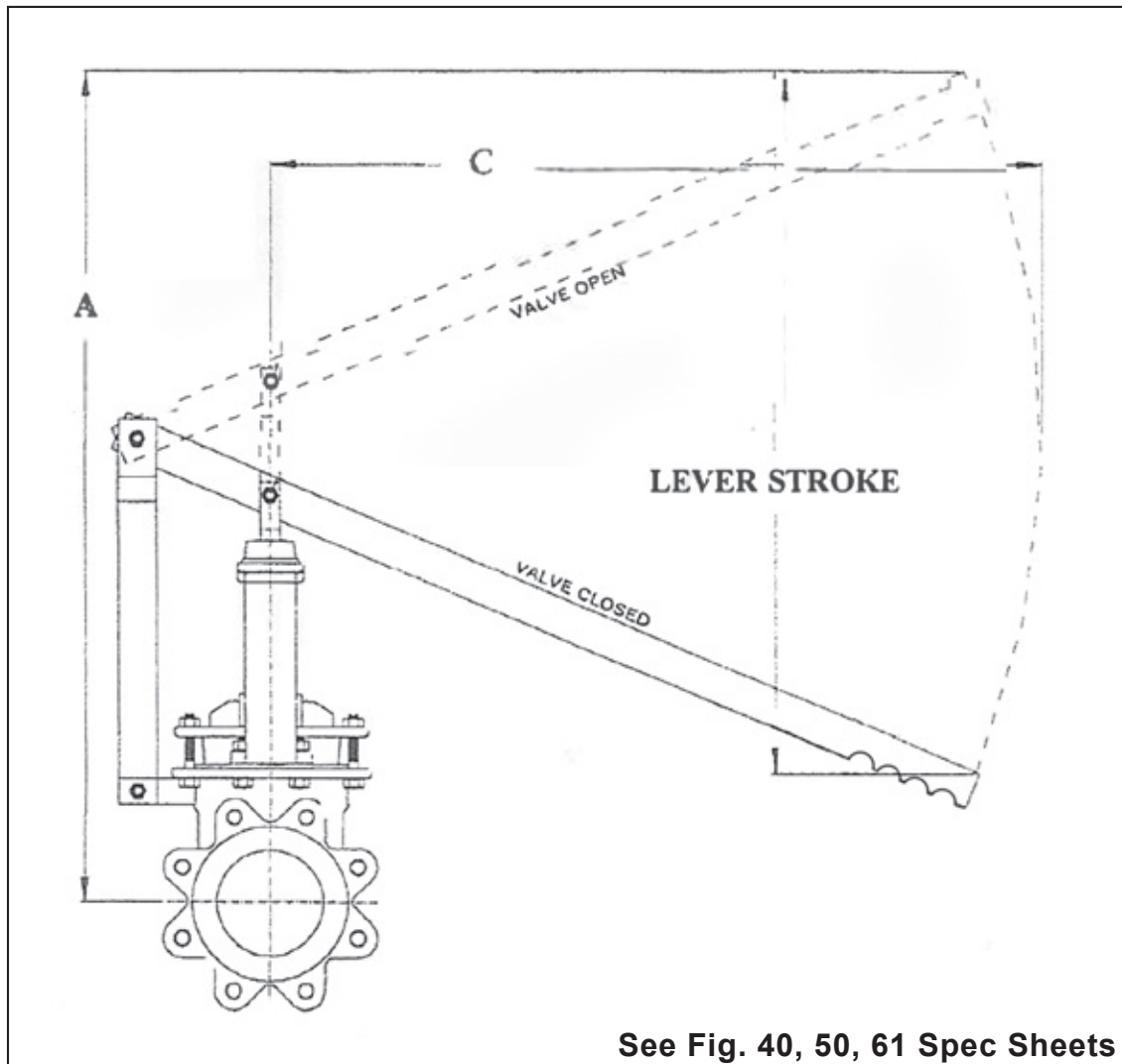

LEVER DIMENSIONS

VALVE SIZE	A	LEVER STROKE	C
2"	26"	18"	19"
3"	31"	23"	25"
4"	36"	27"	31"
6"	46"	34"	37"
8"	52"	38"	40"



- Lever operators are not recommended on metal seated valve above 8" and resilient seated valves above 6"
- Lever operators can be either factory installed or supplied in kit form to be installed in the field.
- A stem "t" lock bolt is supplied on resilient seated valves to secure the gate in place for drip tight shutoff

NOTE: LEVER DIMENSIONS ARE APPROXIMATE AND MAY VARY SLIGHTLY BETWEEN STYLES OF VALVES.

Knife Gate Valves & Custom Fabrication / phone (360) 425-0306, fax (360) 425-0353