



Fabricast Valve Company
 1061 Industrial Way, Longview, WA 98632
 Toll-Free 1-877-264-2503
 Local (360) 425-0306 Fax (360) 425-0353
 www.knifegates.com
 sales@fabricastvalve.com



FIG 50

FIG 50

Fabricast Valve

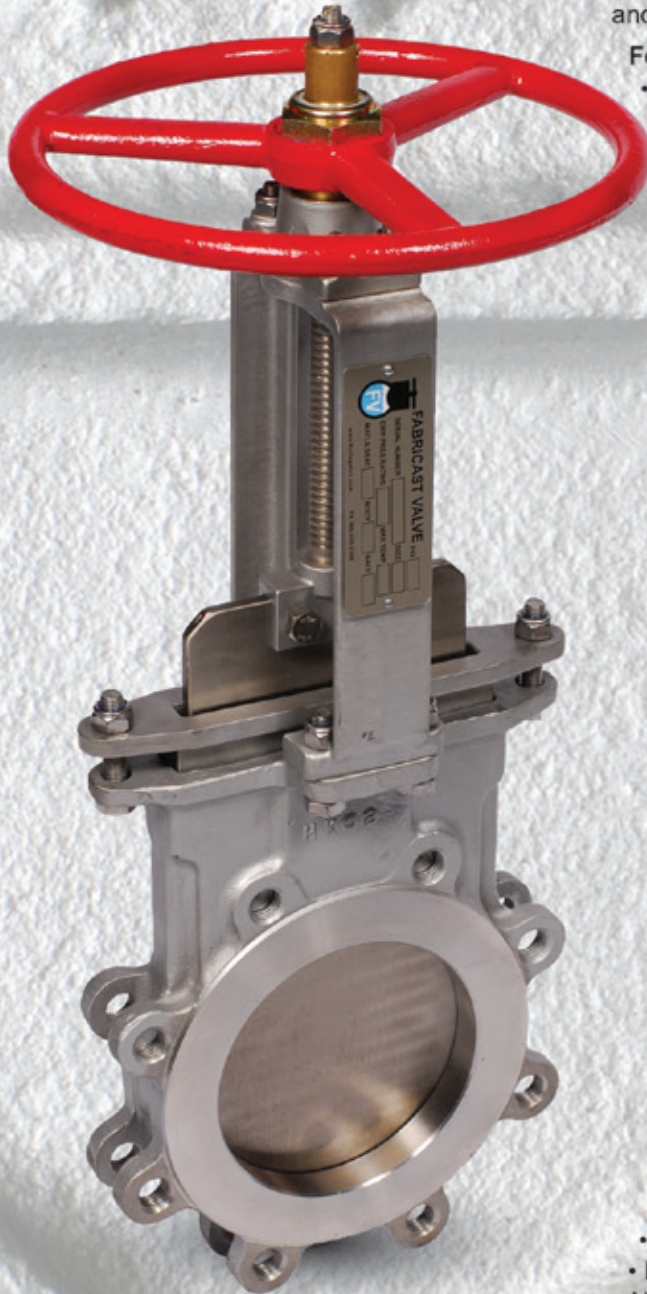

The Fabricast FIG 50 is a resilient (rubber) seated, perimeter sealed Bi-directional Knife Gate valve. Designed and tested to MSS SP81 and ASME B16.5 specifications.

Features

- Heavy Duty Cast CF8 T304, CF8M T316 or CG8M T317 body and packing gland. Cast CF8 T304 yoke, stemnut retainer and gate clevis. Sizes larger than 36" are available in a fabricated and welded design.
- Full Port
- 150 PSI CWP Rated
- Precision CNC machined valve body and stem
- ASTM a 240 304, 316, 317 Stainless Steel gate fully machined and surface ground. All edges are chamfered to extend packing life and to provide a superior atmospheric seal.
- 14" and larger valves are supplied with a ball bearing yoke bushing to reduce handwheel rimpull
- Braided Teflon Synthetic Packing is standard 3-11 PH rating.
- BUNA N seat is standard 180 Deg. F.
- Locking fasteners are standard on all Fabricast valves
- Cast WCB Steel handwheel (weldable)
- Easily adapted to Air Cylinder, Hydraulic Cylinder, Bevel Gear, Lever or Electric Motor Operator (no welding required)

Options

- Seat - EPDM 300 Deg F, FKM/VITON 400 Deg F, PTFE 500 Deg F, Other - Contact factory
- Other alloys - 316, 317I, Duplex 2205, 2507, 904L, Hastelloy, Titanium
- Other - Contact factory
- Mechanical lockouts - manual and actuated valves
- Osha gate guard
- Pneumatic, hydraulic and spring cylinder, electric motor operator, 3:1 and 4:1 bevel gear operator, chainwheel, stem extensions, lever operator.
- Packings - PTFE, Graphite, Kevlar, Food Grade, Other - Contact factory
- Purge / flushing ports
- Limit / proximity switches, solenoid valves, positioners, air sets, speed controls, exhaust mufflers, air tank failsafe systems, air boosters
- V port insert for flow control
- Deflector cones for abrasive service
- Ni-resist alloy stemnut
- Live loaded packing system
- Specialty gate coatings
- Hardsurfacing for abrasive service

Previous Model
FV-150-PS

Optional Operators see www.knifegates.com for details



Cylinder



Bevel Gear



Electric Motor



Chain Wheel



Lever



Fabricast Valve Company
 1061 Industrial Way, Longview, WA 98632
 Toll-Free 1-877-264-2503
 Local (360) 425-0306 Fax (360) 425-0353
 www.knifegates.com
 sales@fabricastvalve.com

FIG 50

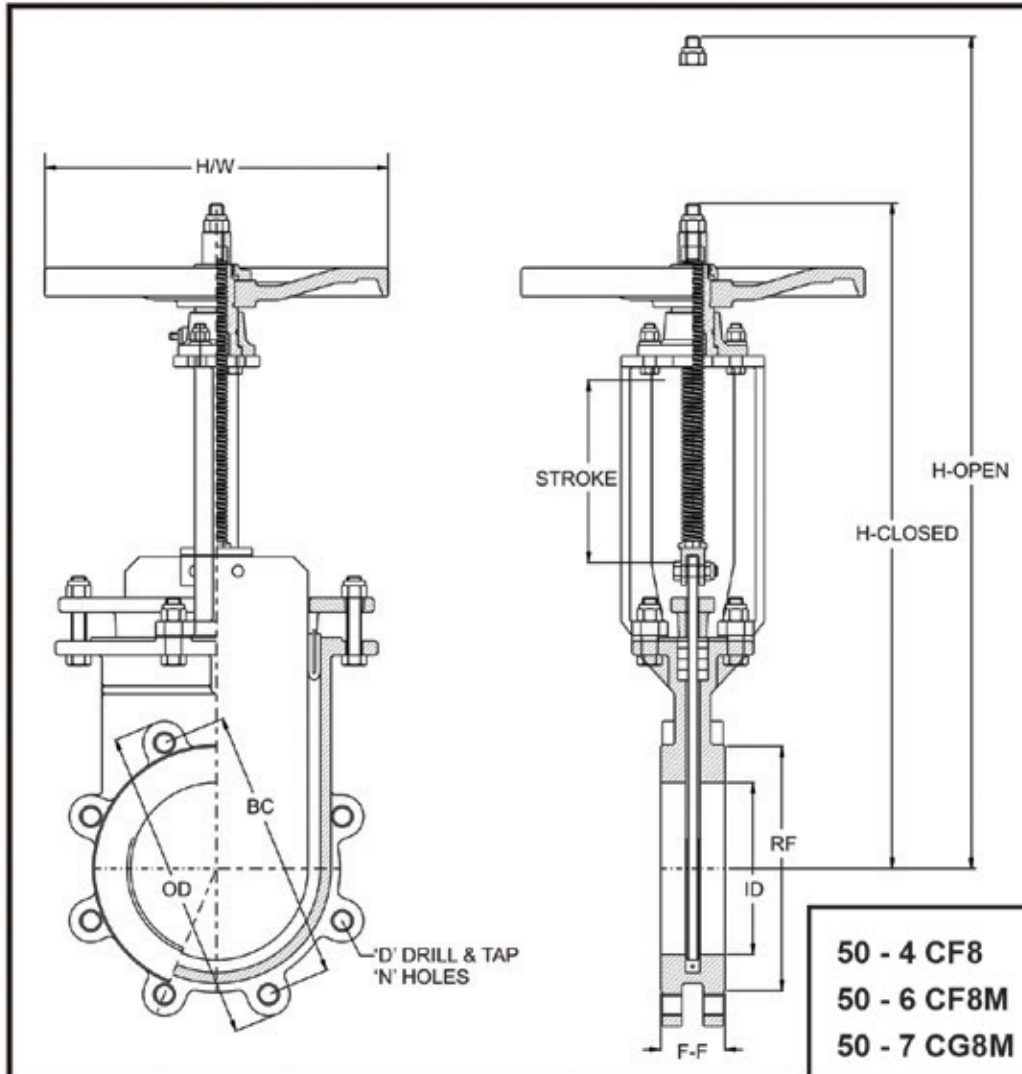

| Size | 2" | 3" | 4" | 6" | 8" | 10" | 12" | 14" | 16" | 18" | 20" | 24" | 30" | 36" |
|--------------------------------------|---------|---------|---------|---------|---------|---------|---------|---------|---------|----------|----------|----------|------|------|
| Face to Face F-F | 1-7/8" | 2" | 2" | 2-1/4" | 2-3/4" | 2-3/4" | 3" | 3" | 3-1/2" | 3-1/2" | 4-1/2" | 4-1/2" | | |
| Flange OD OD | 6" | 7-1/2" | 9" | 11" | 13-1/2" | 16" | 19" | 21" | 23-1/2" | 25" | 27-1/2" | 32" | | |
| Bolt Circle BC | 4-3/4" | 6" | 7-1/2" | 9-1/2" | 11-3/4" | 14-1/4" | 17" | 18-3/4" | 21-1/4" | 22-3/4" | 25" | 29-1/2" | | |
| Inside Diameter ID | 2" | 3" | 4" | 6" | 8" | 10" | 12" | 13/5-8" | 15-1/2" | 17-1/2" | 19-1/2" | 23-3/8" | | |
| Number of Holes N | 4 | 4 | 8 | 8 | 8 | 12 | 12 | 12 | 16 | 16 | 20 | 20 | | |
| Hole D&T Size D | 5/8"-11 | 5/8"-11 | 5/8"-11 | 3/4"-10 | 3/4"-10 | 7/8"-9 | 7/8"-9 | 1"-8 | 1"-8 | 1-1/8"-7 | 1-1/8"-7 | 1-1/4"-7 | | |
| C/L to Top Closed H-Closed | 13-5/8" | 16" | 17-3/4" | 21-5/8" | 26-3/4" | 32-1/8" | 36-3/8" | 42" | 46-3/4" | 52-3/8" | 56" | 62-7/8" | | |
| C/L to Top Open H-OPEN | 16" | 19-3/4" | 21-5/8" | 27-3/4" | 34-3/4" | 42-3/4" | 48-5/8" | 55-1/4" | 63-1/8" | 70-1/2" | 75-5/8" | 85-5/8" | | |
| Handwheel Dia. H/W | 8" | 8" | 8" | 12" | 12" | 15" | 15" | 15" | 20" | 20" | 20" | 30" | | |
| Raised Face Diameter RF | 3-5/8" | 5" | 6-3/16" | 8-1/2" | 10-5/8" | 12-3/4" | 15" | 16-1/4" | 18-1/2" | 21" | 23" | 27-1/4" | | |
| Weight (lbs.) | 20 | 29 | 38 | 52 | 85 | 120 | 160 | 212 | 300 | 350 | 480 | 600 | 1169 | 2425 |

Fabricast Valve
 Knife Gate Valves & Custom Fabrication / phone (360) 425-0306, fax (360) 425-0353



Fabricast Valve Company
1061 Industrial Way, Longview, WA 98632
Toll-Free 1-877-264-2503
Local (360) 425-0306 **Fax** (360) 425-0353
www.knifegates.com
sales@fabricastvalve.com

Fabricast Valve

FIGURE 50-PS RESILIENT SEATED KNIFE GATE VALVE

The Fabricast Valve FIG. 50-PS is a resilient (rubber) seated, perimeter sealed, knife gate valve featuring a cast stainless steel body, packing gland, and yoke. It is designed and tested to conform with MSS SP-81, and ASME B16.5 Class 150 specifications.

The heavy-duty cast body features a full-port I.D. and machined faces. It is designed to withstand up to 150 PSI of pressure as required by MSS SP-81.

As also required by this standard, the ground and machined stainless steel gate is designed to withstand pressures up to 150 PSI.

Our resilient/rubber seat provides a bi-directional, drip-tight seal across the gate for any pressure up to 150 PSI. It is flush with the bottom of the valve, making replacement quick and easy, and eliminating pockets to provide a smooth transition for the pipeline media.

The stainless steel stem resists corrosion, and is accompanied by a stainless steel stem nut retainer that protects the stem bushing from harsh environments, and reduces operating torque.

Our Teflon Synthetic Packing is rated standard with a Ph range of 3-11, and temperature rating up to 500° F.

Converting from the hand wheel operator to cylinder, bevel gear, or electric motor is easy and requires no additional welding.

Available in T304, T316, T317 Stainless Steel.

Flanges match ANSI 150LB, PN10, TABLE "D", JIS 10kg Standard with all tapped holes.

PREVIOUS MODEL NAME FV 150-PS

FABRICAST VALVE



Optional Operators



Cylinder



Lever



Electric

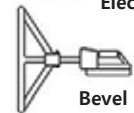

Bevel gear



Chain Wheel



Fabricast Valve Company
 1061 Industrial Way, Longview, WA 98632
Toll-Free 1-877-264-2503
Local (360) 425-0306 Fax (360) 425-0353
 www.knifegates.com
 sales@fabricastvalve.com

Fabricast Valve

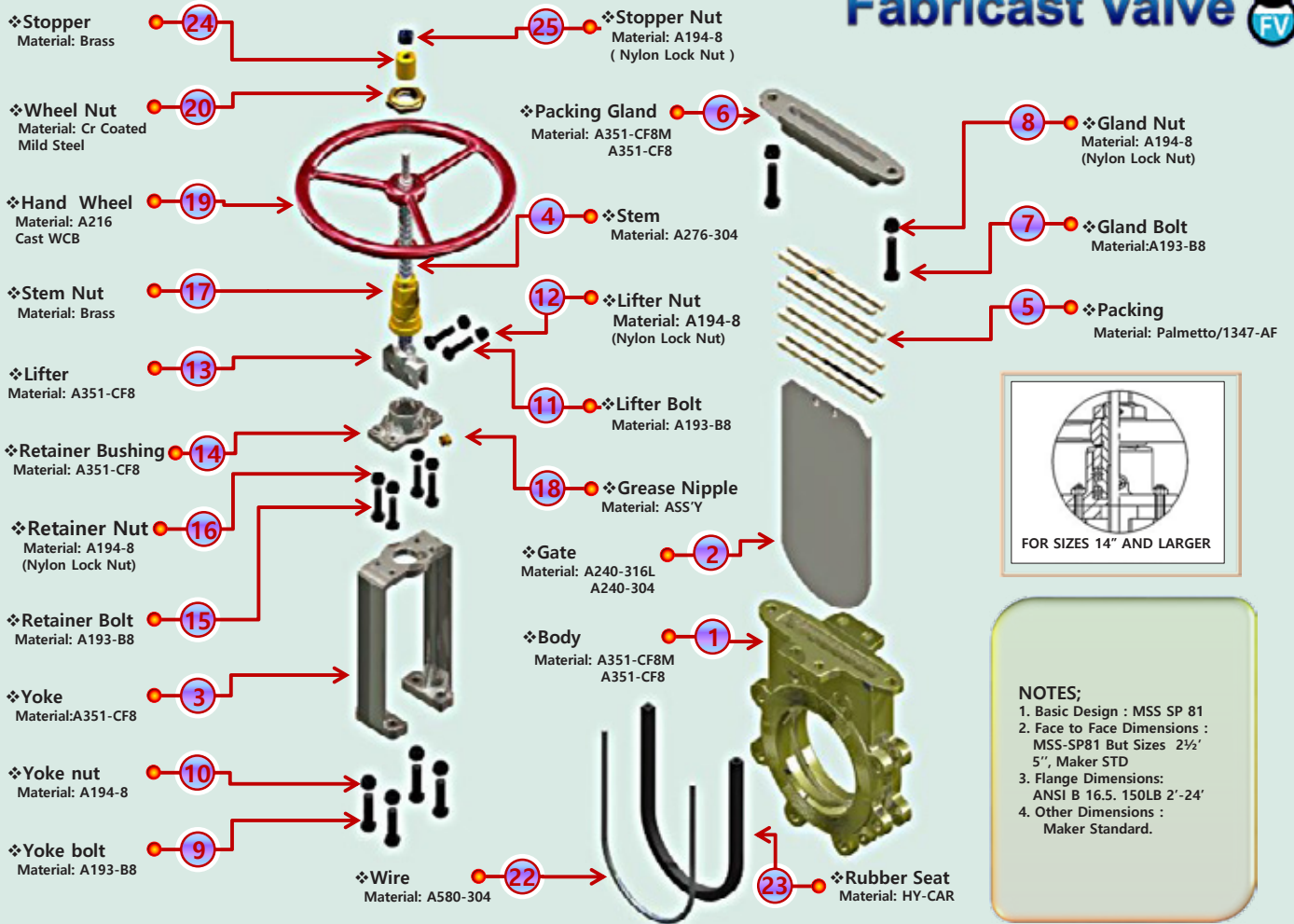



Fabricast Valve Company
 1061 Industrial Way, Longview, WA 98632
Toll-Free 1-877-264-2503
Local (360) 425-0306 Fax (360) 425-0353
 www.knifegates.com
 sales@fabricastvalve.com

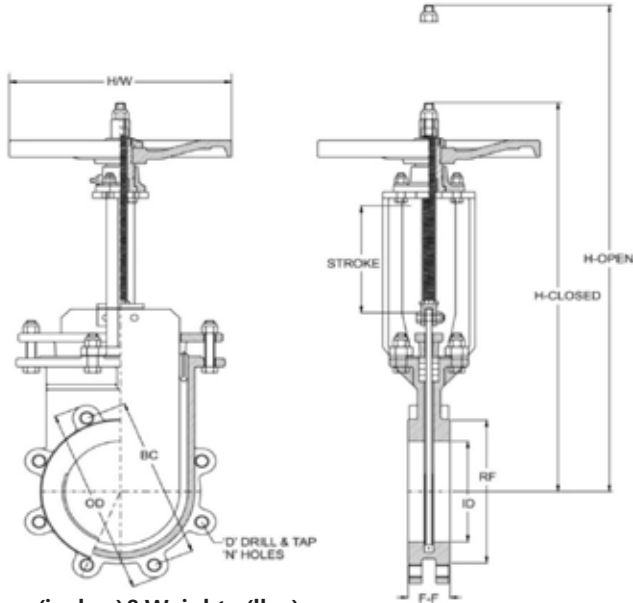

Fabricast Valve 

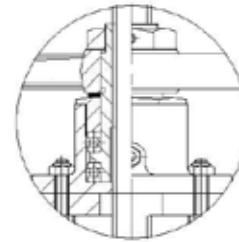

FOR SIZES 14" AND LARGER

30" & 36" COME
 STANDARD WITH
 GEAR OPERATOR

Dimensions (inches)&Weights (lbs.)

| Size | | 2" | 3" | 4" | 6" | 8" | 10" | 12" | 14" | 16" | 18" | 20" | 24" | 30" | 36" |
|-------------------|-----|---------|---------|---------|---------|---------|---------|---------|---------|---------|----------|----------|----------|----------|----------|
| Face to Face | F-F | 1-7/8" | 2" | 2" | 2-1/4" | 2-3/4" | 2-3/4" | 3" | 3" | 3-1/2" | 3-1/2" | 4-1/2" | 4-1/2" | 5-3/16" | 6" |
| Flange | OD | 6" | 7-1/2" | 9" | 11" | 13-1/2" | 16" | 19" | 21" | 23-1/2" | 25" | 27-1/2" | 32" | 38-3/4" | 46" |
| Bolt Circle | BC | 4-3/4" | 6" | 7-1/2" | 11-3/4" | 9-1/2" | 14-1/4" | 17" | 18-3/4" | 21-1/4" | 22-3/4" | 25" | 29-1/2" | 36" | 42-3/4" |
| Inside Diameter | ID | 2" | 3" | 4" | 6" | 8" | 10" | 12" | 13-5/8" | 15-1/2" | 17-1/2" | 19-1/2" | 23-3/8" | 29-1/4" | 35-3/16" |
| Number of Holes | N | 4 | 4 | 8 | 8 | 8 | 12 | 12 | 12 | 16 | 16 | 20 | 20 | 28 | 32 |
| Tap | D | 5/8"-11 | 5/8"-11 | 5/8"-11 | 3/4"-10 | 3/4"-10 | 7/8"-9 | 1"-8 | 1"-8 | 1"-8 | 1-1/8"-7 | 1-1/8"-7 | 1-1/4"-7 | 1-1/4"-7 | 1-1/2"-6 |
| C/L to Top Closed | H-C | 13-5/8" | 16" | 17-3/4" | 21-5/8" | 26-3/4" | 32-1/8" | 36-3/8" | 42" | 46-3/4" | 52-3/8" | 76-1/4" | 91-1/4" | 80" | 111-3/8" |
| C/L to Top Open | H-O | 16" | 19-3/4" | 21-5/8" | 27-4/3" | 34-3/4" | 42-3/4" | 48-5/8" | 55-1/4" | 63-1/8" | 70-1/2" | 96-3/4" | 116" | 114-1/4" | 145-3/4" |
| Handwheel Dia | H/W | 8" | 8" | 8" | 12" | 12" | 15" | 15" | 15" | 20" | 20" | 20" | 30" | 18" | 18" |
| Raised Face Dia | RF | 3-5/8" | 5" | 6-3/16" | 8-1/2" | 10-5/8" | 12-3/4" | 15" | 16-1/4" | 18-1/2" | 21" | 23" | 27-1/4" | 33-3/4" | 40-1/4" |
| Weight (lbs) | | 20 | 29 | 38 | 52 | 85 | 120 | 160 | 212 | 300 | 350 | 480 | 600 | 1136 | 2205 |