



24CC/24CS (shown)

The 24CC and 24CS M/P Converters are motor driven pneumatic regulators with motor assemblies enclosed in a commercial enclosure.

The AC Control Unit for the 24CC unit is a continuous operation motor available in 115vAC.

The control assembly for the 24CS unit is a stepper motor with an integral Translator Board which converts 23-26vAC digital pulse inputs supplied by the customer, into control logic to drive the motor.

### Features

(Varies with 2400 Models)

- Output pressure locks in last position in event of power failure.
- Continuous AC Motor unit is instant start-stop, heavy duty impedance protected unit eliminates coasting and prevents burnout in the event of stalling.
- Stepper Motor capable of rapid start-stop with high running torque enables use in open loop control systems.
- Standard commercial enclosure or explosion-proof NEMA 4X housing for use in hazardous or harsh environments.
- Optional end of travel limit switches for user setting of minimum and maximum pressure values.

### Summary

The table summarizes inputs and outputs for all the 2400 Series M/P Converters. Individual converters are described in separate sections.

Model	24CC	24CS	24XFS
<b>Inputs</b>	115vAC	23-26vDC (logic input)	1-5vDC 4-20Ma DC 12-15vDC 23-26vDC
<b>Outputs</b> psig [BAR] (kPa) <i>Model 30</i>	0-2 [0-0.15] (0-15)	0-10 [0-0.7] (0-70)	2-100 [0.15-7.0] (15-700)
<i>Model 80</i>		0-20 [0-.1.5] (0-150)	1-100 [0.1-7.0] (10-700)
<i>Model 81</i>	0-2 [0-0.15] (0-15)	0-5 [0-0.35] (0-35)	0.5-100 [0.03-7.0] (3-700)
<i>Model 10</i>			0.5-30 [0.03-2.0] (3-200)
<i>Model 16</i>			Vacuum to 10 [Vacuum-0.7] (Vacuum-70)

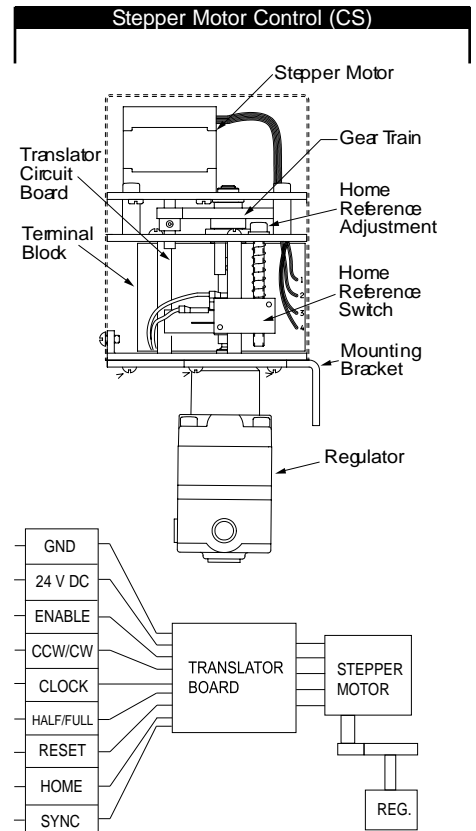
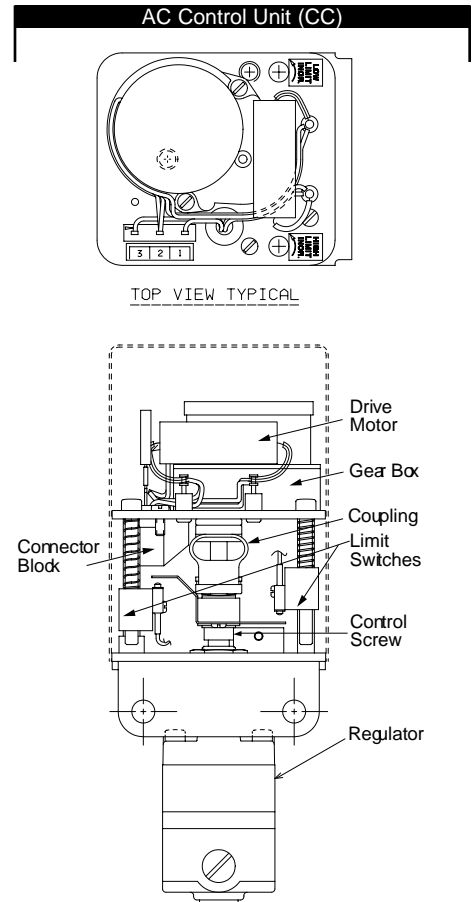

**Environmental**

AC Control Unit  
 Continuous Operation . . . . . -40°F to +100°F  
 (-40°F to +90°C)  
 Intermittent Operation . . . . . -40°F to +150°F  
 (-40°F to +65.5°C)

Stepper Motor  
 Operating Temp. Range . . . . . 0° to +125°F  
 (-17.8°F to +51.6°C)  
 Intermittent Operation . . . . . -40°F to +200°F  
 (-40°F to +93.2°C)

**Electrical**

AC Control Unit  
 Motor Voltage . . . . . 115vAC, 60Hz

Power Consumption (watts)  
 Model 30 Regulator . . . . . 5 (Max.)  
 Model 80 Regulator . . . . . 3 (Max.)  
 Model 81 Regulator . . . . . 3 (Max.)

Stepper Motor with Integral Translator  
 Voltage to translator . . . . . 23-26Vdc @ 800 Ma  
 Power Consumption (watts) . . . . . 21 (Max.)

**Inputs**

**Translator**  
 All inputs except enable  
 Input Signal Voltage (High) . . . . . 2-5v  
 Input Signal Voltage (Low) . . . . . 0-0.8v Max.  
 Input Signal Current (High) . . . . . 0  
 Input Signal Current (Low) . . . . . 0.9 mA (Sink)  
 Enable Input Voltage (Low) . . . . . 0v-1.5v  
 Enable Input Voltage (High) . . . . . 2v-5v  
 Clock Time Duration . . . . . 0.5 us Min.  
 Clock setup . . . . . 1.0 us Min.  
 \* Clock Freq. Range . . . . . 800 Hz Max.

\* Clock frequency between 80 and 200 Hz may cause noise; however, operation of the unit will not be adversely affected.

**Performance**

Standard Unit: Regulator Characteristics

Regulator	Pressure Ranges	NPT	Flow		Exhaust	
			SCFM*	m <sup>3</sup> /HR	SCFM**	m <sup>3</sup> /HR
30	All Ranges	1/4"	30	51	2.0	3.4
80	All Ranges	1/8"	14	23.8	2.5	4.3
81	All Ranges	1/4"	50	85	5.5	9.4

\*100 psig, [7.0 BAR], (700 kPa) pressure 20 psig, [1.5 BAR], (150 kPa) setpoint

\*\* Downstream Pressure 5 psig, [.35 BAR], (35 kPa) above setpoint

**Materials of Construction**

Model 2400 - Steel, Brass, Aluminum, Nylon

NOTE: For Materials of Construction of individual regulators, please see appropriate specification sheet.

**Full Range Adjusting Time (Seconds)**

**AC Control Unit**

Reg. Model	PRESSURE RANGES: psig, [BAR], (kPa)							Motor RPM
	2,[.15],[.15]	5,[.35],[.35]	10,[.7],[.70]	20,[1.5],[.70]	30,[2.0],[.200]	60,[4.0],[.400]	100,[7.0],[.700]	
30	196		256		226	285	256	2
	98		128		113	143	128	4
	65		85		75	95	N/A	6
	49		64		56	71	N/A	8
80				150		148	156	2
				75		74	78	4
				50		49	52	6
				38		N/A	N/A	8
81	156	186		150		148	156	2
	78	93		75		74	78	4
	52	62		50		49	52	6
	39	47		38		N/A	N/A	8

**Stepper Motor**

Reg. Model	PRESSURE RANGES: psig, [BAR], (kPa)							Motor RPM
	2,[.15],[.15]	5,[.35],[.35]	10,[.7],[.70]	20,[1.5],[.70]	30,[2.0],[.200]	60,[4.0],[.400]	100,[7.0],[.700]	
30	.000342		.00131		.00444	.00702	.0139	PSI/STEP PULSE CNT FR ADJ TIME
	5850		7650		6750	8550	7200	
	11.7		15.3		13.6	17.1	14.4	
80				.00444		.0136	.0214	PSI/STEP PULSE CNT FR ADJ TIME
				4500		4410	4680	
				9.0		8.8	9.4	
81	.000427	.000896		.00444		.0163	.0214	PSI/STEP PULSE CNT FR ADJ TIME
	4680	5580		4500		4410	4680	
	9.4	11.2		9.0		8.8	9.4	

DEG/STEP of range screw all models, all pressures . . . . . 0.4°/Step

PULSE COUNT (PULSE CNT) to Full Range

FULL RANGE ADJUSTMENT TIME (FR ADJ TIME) is measured @ 500 PPS for 24vDC Supply

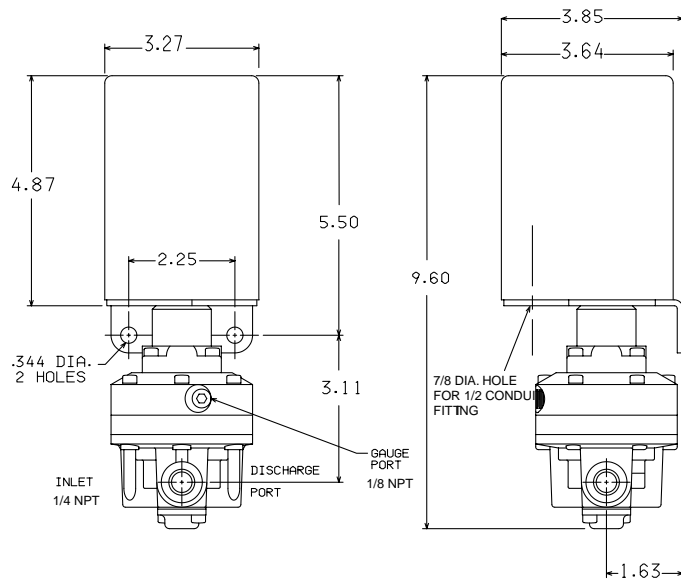
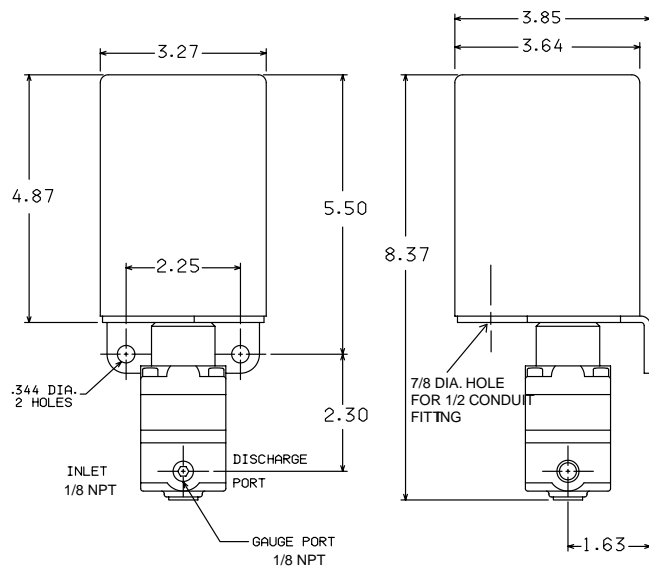
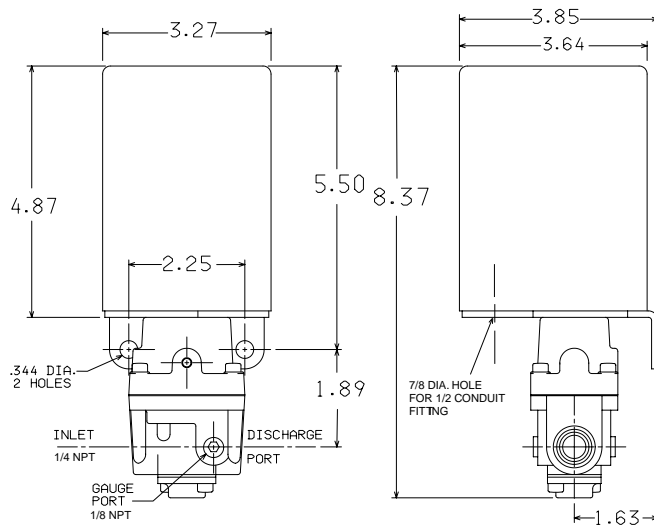
**MODELS: 24CC81 / 24CS81****MODELS: 24CC80 / 24CS80****MODELS: 24CC30 / 24CS30**

NOTE: Mount upright for drip proof operation

**AC Control Unit (CC)**

The Precision M/P Converter consists of a heavy duty industrial permanent magnet type motor with gear box connected through a coupling to a threaded control screw which compresses the positive bias spring assembly of a Model 30, 80, or 81 Precision Regulator.

Limit switches switch off the current to the instant START/STOP motor when a maximum or minimum pressure is achieved. Electrical connections are made to the terminal block inside the motor cover.

A variety of motor options are available to assure optimum adjustment rates according to specification application.

Motor reversal is achieved by applying voltage between the common terminal of the terminal block and the alternate motor winding (both windings are wired to terminals on the terminal block).

**Commercial Stepper Motor**

The Model 2400 M/P Converter equipped with a stepper motor is a digital pulse controlled pneumatic regulator. Principle components include a 200 step/revolution stepper motor, a gear train connecting the motor and range screw, a translator circuit board and a pressure regulator. Switches used in the unit are Home Reference switches.

Electronic circuits in an integral translator convert the digital pulse input signals into control logic that operates a 200 step per revolution stepper motor. The stepper motor in turn controls the output of a pressure regulator by driving its range screw through a 4.5:1 reduction gear. The translator consists of a control logic section and a power output section.

**NOTE:**

The user's computer must supply the digital input pulse in accord with the specifications for stepper motor operation on page 47.

The Control/Logic section contains the logic sequence that determines the proper switching of the stepper motor windings to accomplish rotation. This section accepts the input signal that controls the direction of the motor and the type of switching sequence which is transmitted to the motor windings. This section also contains a pulse width modulated chopper circuit that controls the current in the motor windings.

All inputs have pull up resistors to place them in a HIGH logic state. As a result all inputs can be changed by switch closures. This simplifies manual control circuits and as a result the controlling device does not have to supply input current to the translator inputs.

**Catalog Information**

Please refer to the full range adjustment time table page 47 and select the proper pressure range and regulator model for your application. Choose the speed (rpm) which will provide the closest adjustment time in seconds. Include all appropriate designations as outlined in the following example:

**Catalog Number** 24 C      0

**Control Unit Type**  
 DC Pulse/DC Analog . . . . . S  
 Continuous AC . . . . . C

**Regulator Model**  
 Model 30 . . . . . 30  
 Model 80E . . . . . 80  
 Model 81E . . . . . 81  
 Model 30 BSPT . . . . . 30U  
 Model 80E BSPT . . . . . 80U  
 Model 81E BSPT . . . . . 81U

**Voltage**  
 115 VAC 60 Hz . . . . . 1  
 DC TTL Input with . . . . . 5  
 12-24 VDC Translator Board

**Pressure Range**  

psig	[BAR]	(kPa)	
0-2	[0-0.15]	(0-15)	1
0.5-10 <sup>2</sup>	[0.03-0.7]	(3-70)	2
0.5-20 <sup>1</sup>	[0.03-1.4]	(3-140)	3
0.5-30 <sup>2</sup>	[0.03-2.0]	(3-200)	4
1-60	[0.07-4.0]	(7-400)	5
2-100	[0.15-7.0]	(15-700)	6
0-5 <sup>3</sup>	[0-0.35]	(0-35)	7

**Motor Speed**  
 DC Motor Only . . . . . 00  
 2 rpm . . . . . 02  
 4 rpm . . . . . 04  
 6 rpm . . . . . 06  
 8 rpm . . . . . 08

**Enclosure**  
 Commercial Enclosure . . . . . 0

**Option**  
 Low Temperature (CS Only) . . . . . 3

<sup>1</sup> 0.5-20 psig for Models 80E and 81E Only.  
<sup>2</sup> 0.5-10, 0.5-30 psig for Model 30 Only.  
<sup>3</sup> 0-5 psig for Model 81E Only.



24XC/24XS (shown)

The 24XC and 24XS M/P Converters are motor driven pneumatic regulators with motor assemblies enclosed in a NEMA 4X Explosion-Proof enclosure.

### AC Control Unit (24XC)

The AC Control unit for the 24XC unit is a continuous operation motor available in 115vAC. A feedback potentiometer option is available for these units.

### DC Pulse Input Unit (24XS)

The DC pulse input assembly for the 24 XS unit is a Clock Generator/Translator board available for the 12vDC or 24vDC pulse input. This allows the use of an external Controller with a 12vDC or 24vDC output.

### DC Analog Input Unit (24XS)

The DC analog input assembly is an Amplifier (Proportional Control) and Translator board which allows operation with a 4-20mA or 1-5vDC analog input. Minimum-maximum limit switches are standard on this unit. Reverse action and split ranging on the analog unit can be achieved in the field.

### TTL Input (+5vD) (24XS)

The TTL input unit is equipped with a Translator board only. The user is required to supply the digital input pulses.

The control assembly for the 24XS unit is a stepper motor with an integral Translator board which converts 12vDC or 24vDC digital input pulses supplied by the customer into control logic to drive the stepper motor.

### Environmental

#### AC Control Unit

Continuous Operation . . . . . -40°F to +100°F  
 (-40°F to +90°C)  
 Intermittent Operation . . . . . -40°F to +150°F  
 (-40°F to +65.5°C)

#### DC Pulse/DC Analog Input Unit

Operating Temp. Range . . . . . 0° to +125°F  
 (-17.8°F to +51.6°C)  
 Low Temp. Option . . . . . -40°F to +200°F  
 (-40°F to +93.2°C)

### Electrical

#### AC Control Unit

Motor Voltage . . . . . 115vAC, 60Hz  
 Power Consumption (watts)  
 Model 10 Regulator . . . . . .5 (Max.)  
 Model 16 Regulator . . . . . .3 (Max.)  
 Model 80 Regulator . . . . . .3 (Max.)  
 Model 81 Regulator . . . . . .3 (Max.)

#### Stepper Motor

Input to Translator Board . . . . . 12-24vDc @ 800 Ma

### Inputs

#### Translator

All inputs except enable

Input Signal Voltage (High) . . . . . .2-5v  
 Input Signal Voltage (Low) . . . . . .0-0.8v Max.  
 Input Signal Current (High) . . . . . .0  
 Input Signal Current (Low) . . . . . .0.9mA (sink)  
 Enable Input Voltage (Low) . . . . . .0v-1.5v  
 Enable Input Voltage (High) . . . . . .2v-5v  
 Clock Time Duration . . . . . .0.5 us Min.  
 Clock Setup . . . . . .1.0 us Min.  
 Clock Freq. Range . . . . . .800Hz Max.

\* Clock frequency between 80 and 200 Hz may cause noise; however, operation of the unit will not be adversely affected.

#### DC Pulse Input

Input to Clock Generator/Translator Board . . . . . 12-15vDC  
 or 23-26vDC @ 800 mA  
 Signal Current (sink) . . . . . .10mA @ 24v  
 Power Consumption (watts) . . . . . .21 (max.)  
 for 12-24vDC

#### DC Analog Input

Input to Amplifier  
 (Proportional Control)/Translator . . . . . 4-20mA  
 1-5vDC  
 Power Supply . . . . . 12-24vDC

### Hazardous Locations

#### FM (Factory Mutual) Approval:

Class I, Division I, Groups B, C and D; dust ignition proof for Class II, Division I, Groups E, F, and G; indoor and outdoor (NEMA Type 4X)

### Performance

#### Standard Unit- Regulator Characteristics

Regulator	Pressure		Flow		Flow	
	Ranges (psig)	NPT	SCFM*	m <sup>3</sup> /HR	SCFM**	m <sup>3</sup> /HR
10E	0-30	1/4"	40	68	5.5	9.4
16 <sup>1</sup>	Vacuum to 10	1/4"	2.5	4.3		
80E	All Ranges	1/8"	14	23.8	2.5	4.3
81E	All Ranges	1/4"	50	85	5.5	9.4

\* 100 psig, [7.0 BAR], (700 kPa) pressure 20 psig, [1.5 BAR], (150 kPa) setpoint

\*\* Downstream Pressure 5 psig, [.35 BAR], (35 kPa) above setpoint

<sup>1</sup> At 29" Hg vacuum

#### Materials of Construction

Model 2400 - Steel, Brass, Aluminum, Nylon

**NOTE:** For Materials of Construction of individual regulators, please see appropriate specification sheet.

Full Range Adjusting Time (seconds) DC Pulse/DC Analog Input Unit 12vDC Supply							
Estimated Full Range Adjusting Time (seconds)				12VDC Supply			
Reg. Model	Pressure Ranges psig [BAR] (kPa)			Mode of Operation			
				Full Step		Half Step	
				Full Range Adj. Times (seconds)		Full Range Adj. Times (seconds)	
10E	.5-30	0.03-2.0	3-200	25	25	26	48
	6-30	0.4-2.0	40-200	20	20	21	38
	3-27	0.2-1.8	20-180	17	20	19	38
	3-15	0.2-1.0	20-100	6	10	8	21
	3-9	0.2-0.6	20-60	3	6	4	11
	9-15	0.6-1.0	60-100	3	5	4	11
16	vac-10	vac-0.7	vac-70	not capable of performing in this range		26	43
80E	.5-20	0.03-1.5	3-150	10	14	11	28
	1-60	0.1-4.0	10-400	10	14	11	28
	2-100	0.15-7.0	15-700	13	13	8	17
81E	0-2	0-0.15	0-15	6	14	12	28
	0-5	0-0.35	0-35	8	21	16	41
	.5-20	0.03-1.5	3-150	10	14	11	28
	1-60	0.1-4.0	10-400	10	14	11	28
	2-100	0.15-7.0	15-700	13	13	8	17

DC Pulse/DC Analog Input Unit 24vDC Supply							
Estimated Full Range Adjusting Time (seconds)				12VDC Supply			
Reg. Model	Pressure Ranges psig [BAR] (kPa)			Mode of Operation			
				Full Step		Half Step	
				Full Range Adj. Times (seconds)		Full Range Adj. Times (seconds)	
10E	.5-30	0.03-2.0	3-200	13	25	18	48
	6-30	0.4-2.0	40-200	11	20	15	38
	3-27	0.2-1.8	20-180	10	20	14	38
	3-15	0.2-1.0	20-100	4	10	8	21
	3-9	0.2-0.6	20-60	2	6	4	11
	9-15	0.6-1.0	60-100	2	5	4	11
16	vac-10	vac-0.7	vac-70	13	22	16	43
80E	.5-20	0.03-1.5	3-150	6	14	12	28
	1-60	0.1-4.0	10-400	7	14	11	28
	2-100	0.15-7.0	15-700	4	13	8	17
81E	0-2	0-0.15	0-15	6	14	12	28
	0-5	0-0.35	0-35	8	21	16	41
	.5-20	0.03-1.5	3-150	6	14	12	28
	1-60	0.1-4.0	10-400	7	14	11	28
	2-100	0.15-7.0	15-700	4	13	8	17

Full Range Adjusting Time (seconds) AC Control Unit								
Reg. Model	Pressure Range psig, [BAR], (kPa)							Motor RPM
	2,[.15],[.15]	5,[.35],[.35]	10,[.7],[.70]	20,[1.5],[150]	30,[2.0],[200]	60,[4.0],[400]	100,[7.0],[700]	
10E					270			2
					135			4
					90			6
					68			8
16			210					2
			105					4
			70					6
			52					8
80E				132		132	141	2
				66		66	71	4
				44		44	47	6
81E	141	180		129		129	135	2
	71	90		65		65	68	4
	47	60		43		43	45	6
	35	45		32		N/A	N/A	8

**Full Range Adjusting Time for TTL Unit**  
 NOTE: Required PPS for a specific FR Adj. Time can be calculated as follows:  

$$PPS = \frac{FR\ Adj.\ Time\ @\ 500\ PPS \times 500}{Required\ Fr\ Adj.\ Time}$$
 For 110.8 Second Time Requirement  

$$PPS = \frac{13.3 \times 500}{110.8} = 60.01\ PPS$$

**AC Control (XC)**

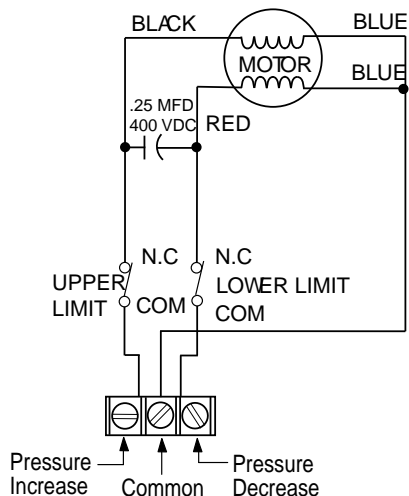
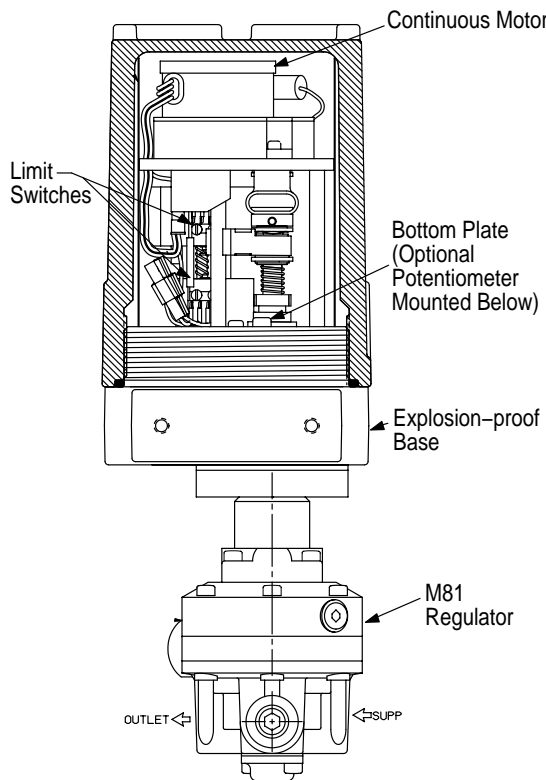
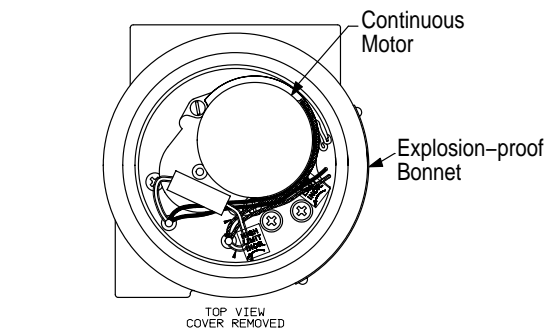

**Explosion-Proof AC Control Unit (XC)**

The Model 2400 M/P Converter is isolated from an explosive environment by enclosing it in an explosion-proof housing. The Continuous Motor configuration includes limit switches.

The Continuous Motor is mounted on the top plate of the motor assembly. Wiring to the unit is made to a terminal block through a 1/2-14 NPT conduit fitting in the base of the housing.

The units as configured at the factory are wired so that connections to the motor are wired to the Normally Closed terminals of the limit switches. Customer connections are made to the Normally Open terminals of the the limit switches.

An optional potentiometer can be provided so that a feedback voltage proportional to the range screw travel is available to the customer. The potentiometer is accessed through the conduit fitting in the base of the housing.

Motor reversal is achieved by applying voltage between the common terminal of the block and the alternate motor winding.

**Explosion-Proof Stepper Motor (CC)**

The Model 2400 M/P Converter equipped with a stepper motor is a digital pulse controlled pneumatic regulator. Principle components include a 200 step/revolution stepper motor, a gear train connecting the motor and range screw, a translator circuit board and a pressure regulator. Switches used in the unit are Home Reference switches.

Electronic circuits in an integral translator convert the digital pulse input signals into control logic that operates a 200 step per revolution stepper motor. The stepper motor in turn controls the output of a pressure regulator by driving its range screw through a 4.5:1 reduction gear. The translator consists of a control logic section and a power output section.

**NOTE:**

The user's computer must supply the digital input pulse in accord with the specifications for stepper motor operation on page 47.

The Control/Logic section contains the logic sequence that determines the proper switching of the stepper motor windings to accomplish rotation. This section accepts the input signal that controls the direction of the motor and the type of switching sequence which is transmitted to the motor windings. This sections also contains a pulse width modulated chopper circuit that controls the current in the motor windings.

All inputs have pull up resistors to place them in a HIGH logic state. As a result all inputs can be changed by switch closures. This simplifies manual control circuits and as a result the controlling device does not have to supply input current to the translator inputs.

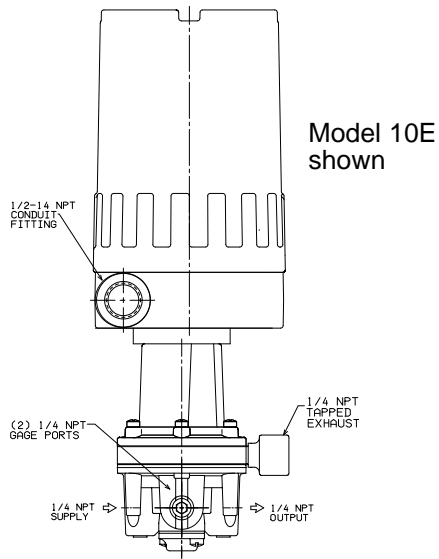
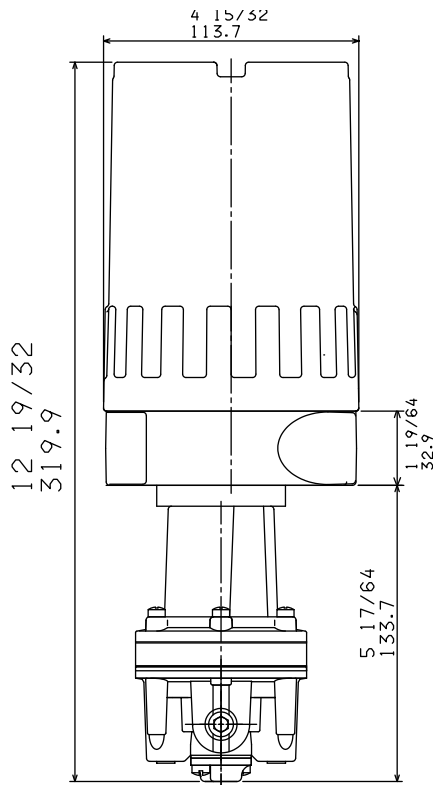
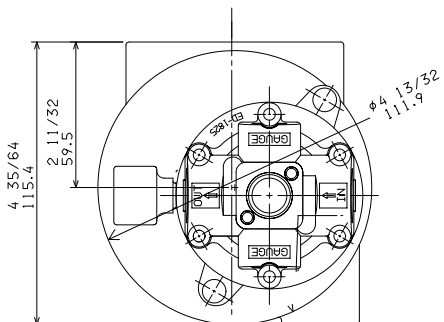
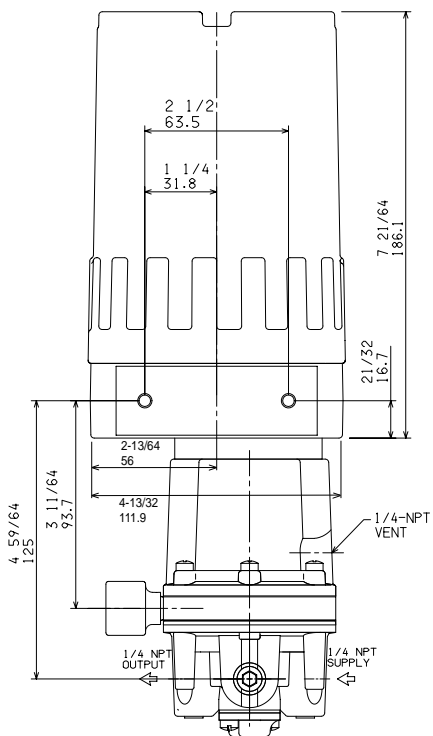
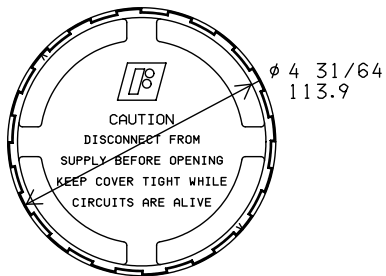



### Clock Generator Limit Switch Connection

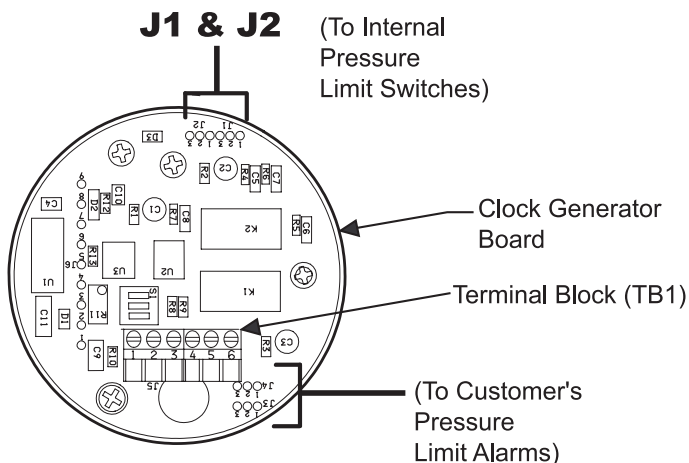

**Table 1. Clock Generator PC Board Wiring Connections**

From Connector	Color	Function	To Closure
J1-1	Green	Internal High Pressure Limit Switch	Normally Open
-2	White/Green		Normally Closed
-3	Black		Common
J2-1	Red	Internal Low Pressure Limit Switch	Normally Open
-2	White/Red		Normally Closed
-3	White/Black		Common
J3-1	Gray	Customer's High Pressure Limit Alarm	Common
-2	White/Yellow		Normally Closed
-3	Yellow		Normally Open
J4-1	Brown	Customer's Low Pressure Limit Alarm	Common
-2	White/Orange		Normally Closed
-3	Orange		Normally Open

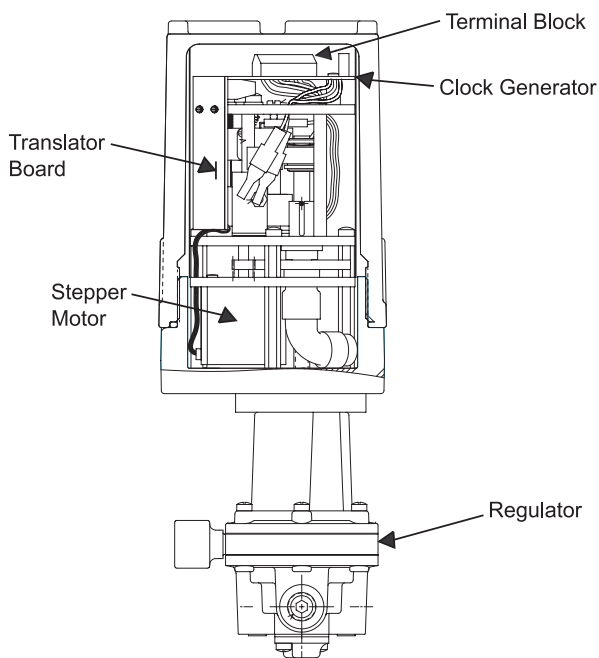

### Explosion-Proof DC Pulse Input (XS)

The Model 2400 M/P Converter is isolated from an explosive environment by enclosing in an explosion-proof housing. The Stepper Motor configuration is equipped with a clock generator positioned horizontally, which plugs into a vertically mounted translator board. The configuration includes limit switches.

The Stepper Motor is mounted on the bottom of the motor assembly in the base of the explosion-proof housing. Wiring to the unit is made to a terminal board through a 1/2" - 14 NPT conduit fitting in the base of the housing.

The unit includes two single pole, double throw, double break limit switches.

Switches on the clock generator board allow selection of:

- a) Internally or Externally powered controls loops.
- b) Half-step or Full step mode.
- c) High-Speed or Low-Speed operation.

**Pulse Input**

Input Board

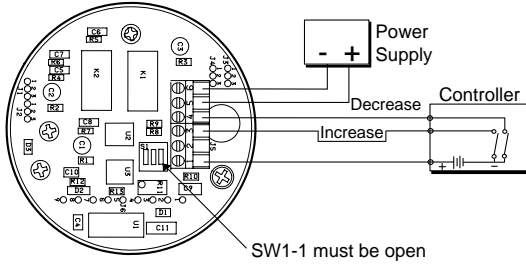

Controller (Pulse Input) using the isolated loop supply.

Input Board

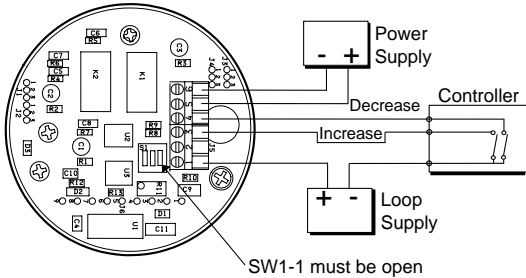

Controller (Pulse Input) using the dual isolated loop supply.

Input Board

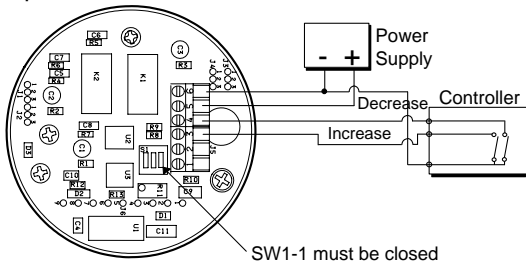

Controller (Pulse Input) using the non-isolated loop supply.

**Analog Input**

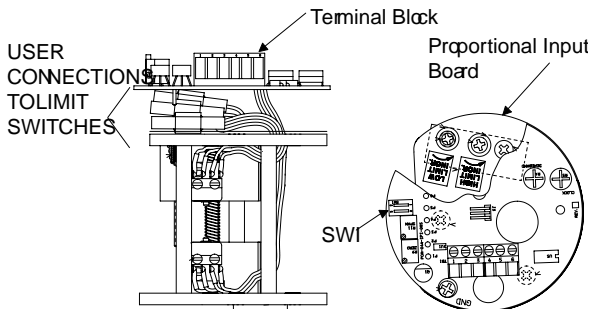

**External Control Connections - Explosion-Proof (XS) Unit**

The Explosion-Proof stepper motor unit is equipped with a Clock Generator and a Translator. Connections from an external Controller are made to the terminal clock on the Input Board as shown.

a) Controller with Isolated Loop Supply

FROM	TO
External Controller +DC	Input Board TB-1 Term 1
Switch Closure	TB-1 Term 3 (Increase)
Switch Closure	TB-1 Term 4 (Decrease)

b) Controller with Dual Isolated Loop Supply

FROM	TO
External Controller +DC	Clock Generator DC Supply TB-1 Term 1
Switch Closure	TB-1 Term 3
	TB-1 Term 4
	TB-1 Term 1

c) Controller using supply which powers Model 2400 as Control Loop Supply

FROM	TO
External Controller +DC	DC Supply Clock Generator
Switch Closure	TB-1 Term 3
Switch Closure	TB-1 Term 4

**Explosion-Proof DC Analog Input (XS)**

The Model 2400 M/P Converter is isolated from an explosive environment by enclosing it in an explosion-proof housing. The stepper motor configuration for this option is equipped with a Proportional Board mounted horizontally on the top of the Motor Assembly.

The output of the 4-20 mA Proportional Board is wired to a vertically mounted translator board. The configuration includes limit switches.

The stepper motor is mounted on the bottom of the motor assembly in the base of the explosion-proof housing. Wiring to the unit is made to a terminal block through a 1/2-14 NPT conduit fitting in the base of the housing.

There is one switch (SW-1) located on the 4-20 mA board. SW-1 is made up of two switches (S1 and S2). S1 selects forward or reverse operation; S2 full or half step operation.

### DC Analog Control

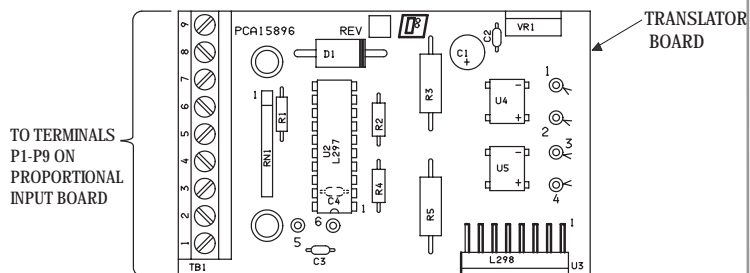
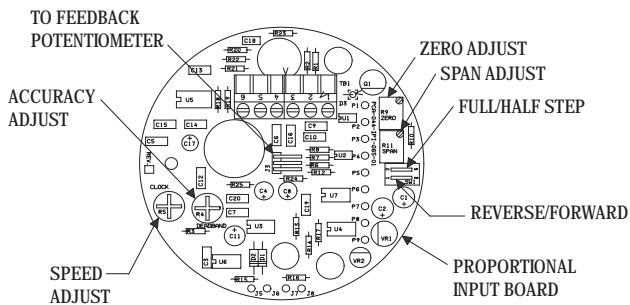
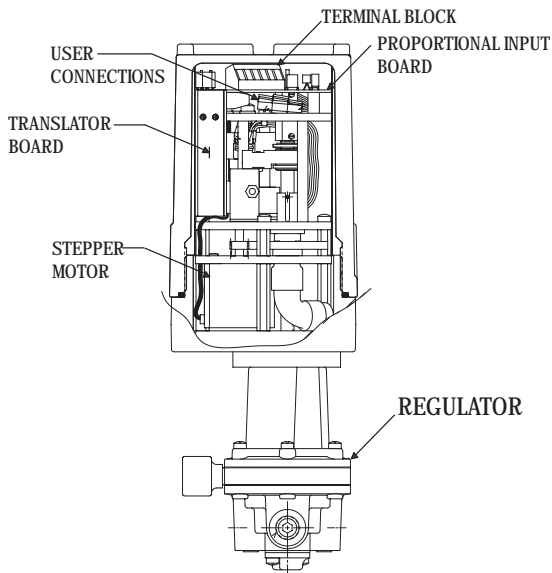
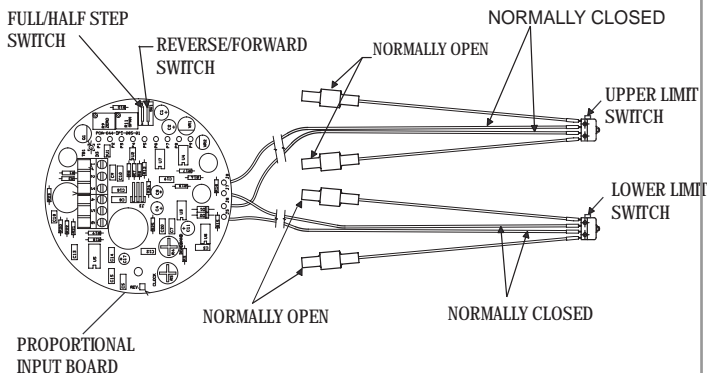

### External Control Connections - Explosion-Proof (XS) Unit

#### Analog Input

#### 4-20 mA, 1-5vDC Input

Connections are made to Terminal Board TB-1 as follows:

Terminal	Input Connection
1	4-20 mA signal current from Controller (+)
2	4-20 mA or 1-5vDC return (-)
3	1-5vDC signal voltage from Controller (+)
4	24vDC Power (+)
5	Common

The unit includes two single pole, double throw, double break limit switches. The Normally Closed terminals are used in the internal control circuit.

Normally Open terminals of the limit switches have connections available for customer use.

Switches on the Proportional Control Board allow selection of :

- Reverse or Forward Operation.
- Half-step or Full-step Mode.

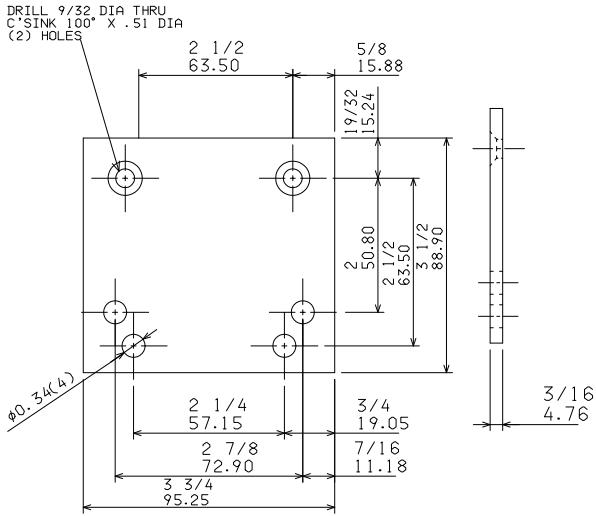

**Mounting Plate: 18188-1** part of **18187-1** (Optional)  
Mtg. Kit includes 2 screws, 1-1/2" and 2" pipe clamps

**Model 2400 Explosion-Proof Kit & Accessories**

Mounting Plate .....18188-1  
Part of 18187-1 (sold separately)

**Catalog Information**

Catalog Number 2 4 X F      0

**Control Unit Type**  
DC Pulse/DC Analog ..... S  
Continuous AC ..... C

**Regulator Model**  
Model 10E ..... 10  
Model 16 ..... 16  
Model 80E ..... 80  
Model 81E ..... 81  
Model 10E BSPT ..... 10U  
Model 16 BSPT ..... 16U  
Model 80E BSPT ..... 80U  
Model 81E BSPT ..... 81U

**Voltage**  
115 VAC 60 Hz ..... 1  
115 VAC 60 Hz with 1K Potentiometer .... 10  
DC TTL Input with ..... 5  
12-24 VDC Translator Board  
DC Pulse Input with ..... 7  
24 VDC Clock Generator Control  
DC Pulse Input with ..... 8  
12 VDC Clock Generator Control  
DC Analog Input with ..... 9  
12-24 VDC Supply

**Pressure Range**

	psig	[BAR]	(kPa)	
Model 10E	0.5-30	[0.03-2.0]	(3-200) ....	4
	0.5-20 <sup>1</sup>	[0.03-1.5]	(3-150) ....	3
Model 16	vac-10	[vac-0.7]	(vac-70) ....	8
Model 80E	0.5-20	[0.03-1.5]	(3-150) ....	3
	1-60	[0.07-4.0]	(7-400) ....	5
	2-100	[0.15-7.0]	(15-700) ...	6
Model 81E	0-2	[0-0.15]	(0-15) ....	1
	0.5-20	[0.03-1.5]	(3-150) ....	3
	1-60	[0.07-4.0]	(7-400) ....	5
	2-100	[0.15-7.0]	(15-700) ...	6
	0-5	[0-0.35]	(0-35) ....	7

**Motor Speed**  
DC Motor Only ..... 00  
2 rpm ..... 02  
4 rpm ..... 04  
6 rpm ..... 06  
8 rpm ..... 08

**Enclosure**  
FM Explosion-Proof ..... 2  
FM Explosion-Proof ..... 3  
with expanded temperature operation (XS Only).

<sup>1</sup> Available on 24XFC Only.