

VAL-MATIC®

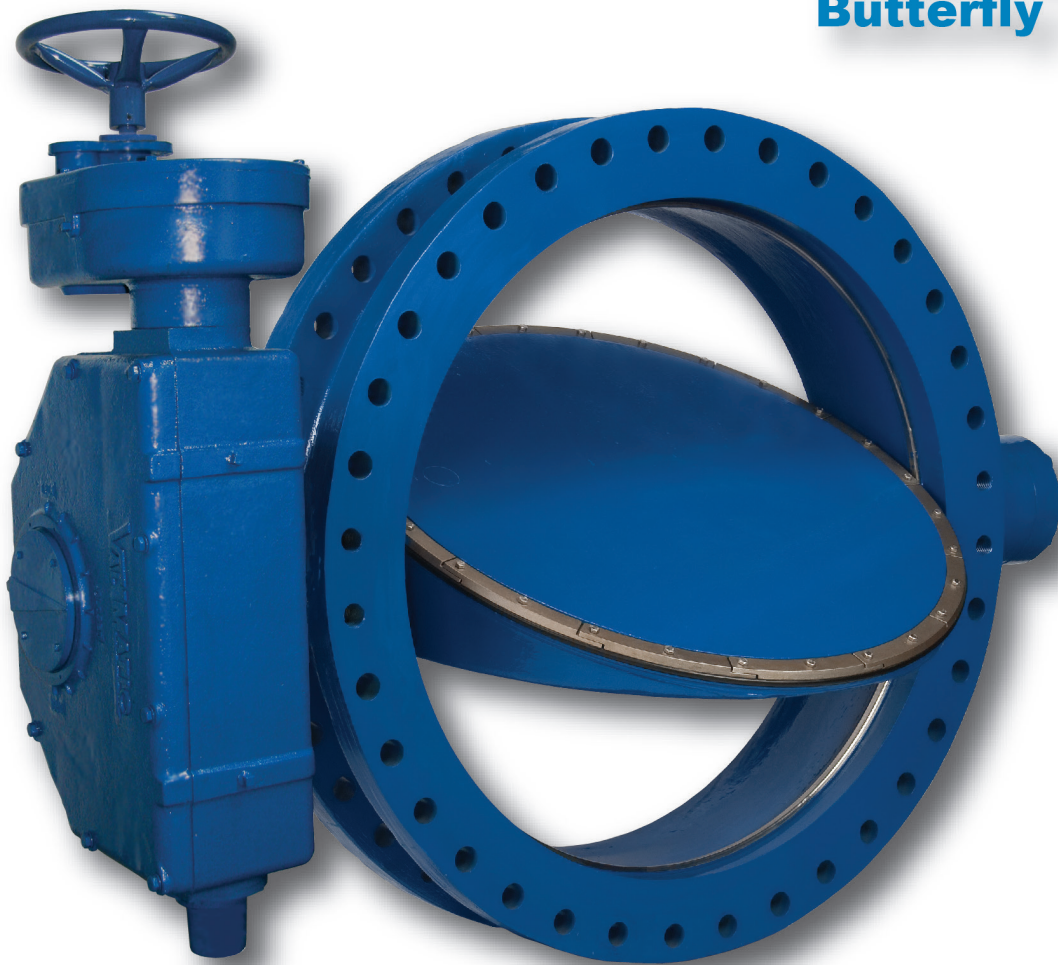

AWWA
Rubber Seated
Butterfly Valve



www.valmatic.com

Meets AWWA C504 & C516
NSF/ANSI 61 & 372 Certified

Feature Highlights

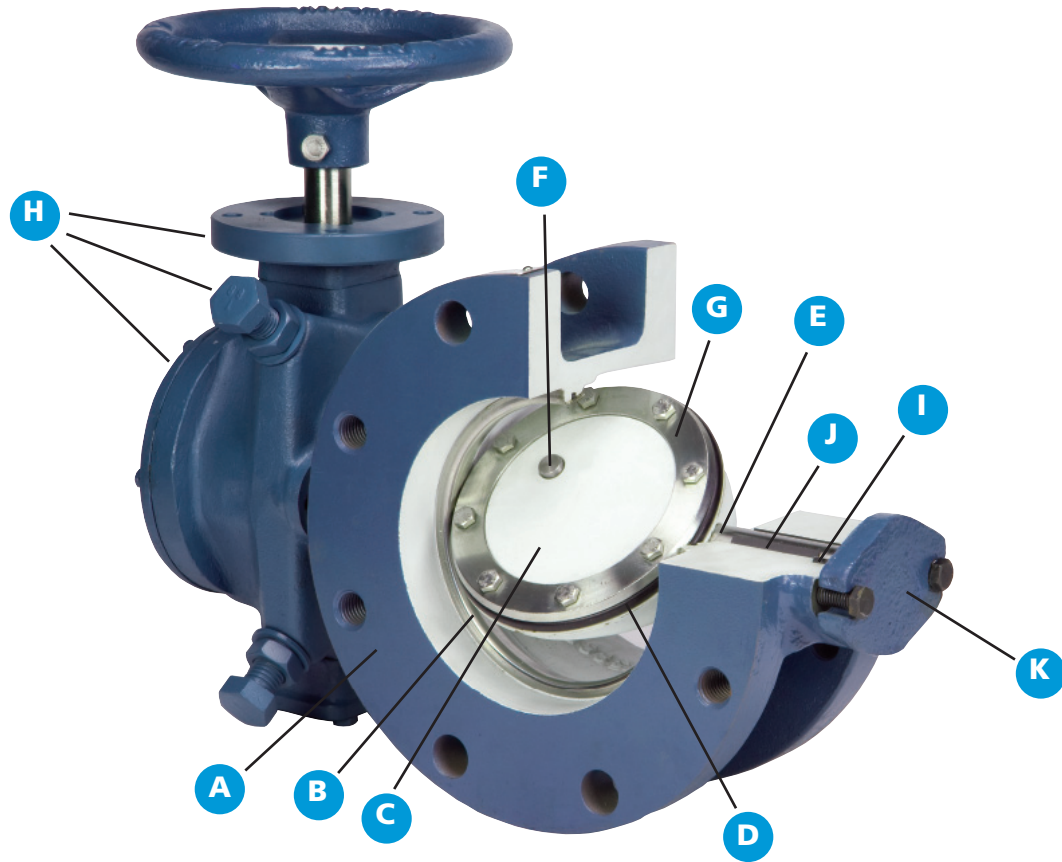

A. Body

Available in Wafer, Lug, Flanged, Mechanical Joint and Flange x Mechanical Joint End Connections in AWWA Classes 150B and 250B.

B. Body Seat

360° uninterrupted body seat with no shaft penetration ensures leak free performance. Type 316 Stainless Steel provides long life and corrosion free mating surface for resilient seat.

C. Ductile Iron Disc

Ductile Iron provides strength and rigidity to withstand dynamic forces from flow and pressure transients. The added strength allows the disc design to have a smaller cross section providing improved headloss characteristics.

D. Resilient Seat

Special formulated elastomers for chemical resistance and long cycle life. The 360° resilient seat is uninterrupted for positive seating.

E. Shaft

Stainless Steel shafts meet AWWA C504 diameter requirements. Through-shafts provided standard on sizes 3" - 24" and available on 30" and larger when specified.

F. Tangential Taper Pins

Stainless Steel Taper Pins with lock nut and o-ring seal utilize tangential forces of the taper pin and lock nut to provide the most secure method available of locking the disc to the shaft.

G. Tri-Loc™ Seat Retention System

With over 40 years of proven dependability the Tri-Loc™ Seating System is easily adjusted and field replaceable. All seat hardware is Type 316 Stainless Steel.

H. Traveling Nut Actuator

The traveling nut design provides characterized closure during the last half of travel. Exclusive externally adjustable stops are rated to 450 ft-lbs of input torque. Standard FA10 motor mounting flange provides ease of automation.

I. Shaft Seal

Shaft seal is a self-adjusting/wear compensating V-Type packing. Packing is easily replaced without removal of the valve from the line.

J. Sleeve Bearings

Low friction bearings are self-lubricating and non-corrosive, for a long, trouble-free life.

K. Thrust Bearing

Factory-set bronze thrust bearing assures proper centering of valve disc. Thrust bearings are field adjustable in sizes 30" and larger.

Preferred Features & Benefits

Proven Design

The American-BFV® is designed, manufactured, and tested to meet all AWWA C504 and C516 requirements including performance tests, leakage tests, and hydrostatic testing. Proof of Design Testing was successfully completed and third-party flow testing was performed at the Utah State Hydraulics Lab, one of the premier testing labs in the world. With thousands of field installations throughout the world, the American-BFV® design has proven dependable since 1971. The valves are certified for use in drinking water in accordance with NSF/ANSI 61 and are NSF/ANSI 372 Certified Lead-Free.

Preferred Features

The American-BFV® provides the features that engineers and users have requested and are included in the AWWA C504 and C516 Butterfly Valve standards. The American-BFV® is designed to provide long life and trouble-free performance. If maintenance becomes necessary, the valve is also designed for easy field service. The shaft seal incorporates V-type packing which is easily replaced in the field without removal from the line. Adjustment of the resilient seat is easily performed with a torque wrench, as compared to epoxy filled seats that require special equipment and materials or bonded seats that cannot be replaced or adjusted in the field.

The unique Tri-Loc™ seat retention system assures seat integrity by securing the seat through three different mechanical methods to assure long-term dependable service, Figure 1. All seat designs provide excellent seating but only the Tri-Loc™ provides ease of adjustment or replacement in the field if ever needed.

The American-BFV® disc is ductile iron in all sizes. The added strength allows the disc design to have a smaller cross section providing improved headloss characteristics. The American-BFV® will withstand flow rates and pressure transients beyond the maximum AWWA pressure rating.

Advanced Technology

Incorporating the latest in valve technology assures a high-quality valve that will provide long service. The design process utilized Solid Modeling and Finite Element Analysis (FEA) of the key structural components. Flow and torque data was derived from flow tests, mathematical models and Computational Fluid Dynamics (CFD). Manufacturing technology uses automated process control in the foundry and ISO 9001 controlled manufacturing processes. Every valve is tested in accordance with AWWA C504 and C516.

Figure 1. Tri-Loc™ Seat Retention System

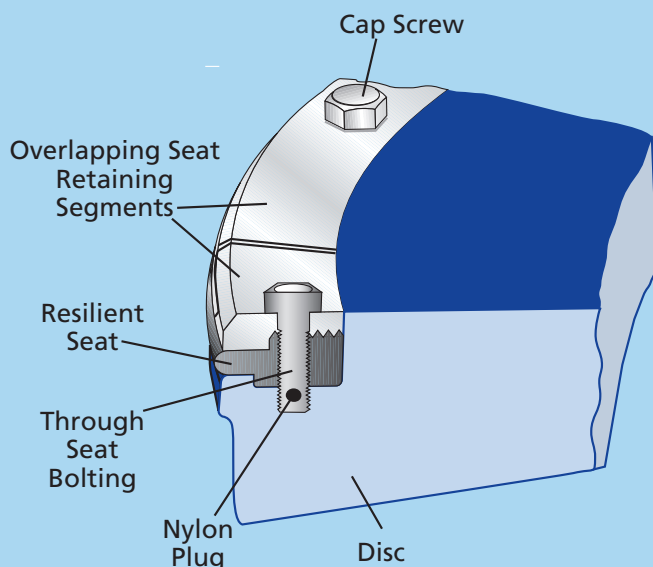

The Tri-Loc™ seat retention system provides reliable sealing and positive mechanical retention of the valve seat while allowing easy adjustment or replacement in the field.

The seat is secured by three methods: 1) clamp force, 2) through the seat bolting and 3) opposing machined registers in the disc and seat retaining ring. Clamp force is provided by tightening the nylon cap screws. Tightening the screws applies pressure to the serrated seat retaining ring which in turn creates a "clamp force" on the rubber molded seat. These same cap screws provide through-bolting seat retention by passing through precision molded holes in the rubber seat. Finally, molded shoulders in the rubber seat are captured by machined registers in the disc and retention ring preventing outward movement of the seat.

Valve Construction

PRESSURE RATINGS

MAXIMUM PRESSURE RATINGS			
SERIES	CONNECTION	AWWA Class	CWP (psig)
2000	ANSI 125# Gray Iron Flange	150B	150
2100	AWWA MJ Gray Iron	150B	150
2200	ANSI 250# Ductile Iron Flange	250B	250
2300	AWWA MJ Ductile Iron	250B	250
2400	ANSI 125# Ductile Iron Flange	250B	250
2500	ANSI 125# Gray Iron Wafer	150B	150
2500L	ANSI 125# Gray Iron Lug	150B	150
2600	ANSI 125# FLG x MJ Gray Iron	150B	150
2700HP*	ANSI 250# FLG Ductile Iron	275C	300

*See Bulletin 2000HP for High Performance Butterfly Valve Information

MATERIALS OF CONSTRUCTION

COMPONENT	STANDARD	OPTIONAL
150B Body 3" - 72"	Cast Iron ASTM A126, Class B	Ductile Iron, Stainless Steel
150B Body 78" - 120"	Ductile Iron ASTM A536 Gr. 65-45-12	Stainless Steel
250B Body 3" - 96"		
Disc	Ductile Iron ASTM A536 Gr. 65-45-12	Stainless Steel
150B Shaft 3" - 72"	Stainless Steel ASTM A276 Type 304	Stainless Steel Type 316, Monel
150B Shaft 78" - 120"	Stainless Steel ASTM A564 Type 630, H1150	Monel
250B Shaft 3" - 84"		
Resilient Seat	Buna-N	EPDM, Viton
Body, Seat and Hardware	Type 316 Stainless Steel	Monel
Shaft Bearings 3" - 24"	Nylatron	Teflon, Bronze
Shaft Bearings 30" and Larger	Teflon-Lined, Fiberglass-Backed	Teflon-Lined, Stainless Steel, Bronze Backed

Headloss Chart

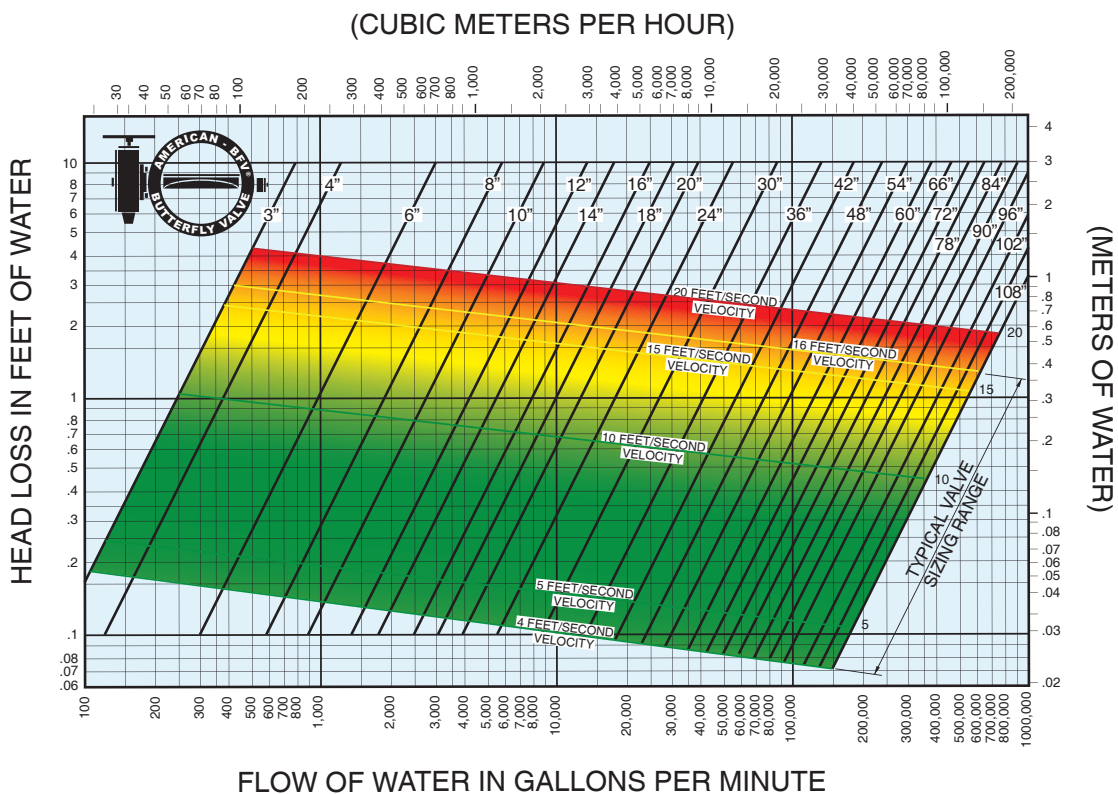

Flow Coefficients	
Size	Cv
3	380
4	590
6	1,430
8	2,750
10	4,300
12	6,550
14	8,350
16	11,800
18	15,000
20	18,600
24	27,000
30	42,000
36	61,900
42	87,100
48	114,000
54	144,000
60	180,000
66	221,000
72	266,500
78	316,000
84	366,000
90	420,500
96	478,500
102	540,000
108	605,500
120	744,000

Actuation/Controls

Val-Matic manufactures a wide variety of manual and power actuators that include traveling nut actuators, worm gears, cylinders and motors. In addition Val-Matic valves are easily adaptable for mounting custom actuators such as: vane, spring-return, rack and pinion, electro-hydraulic, air/oil and other specified cylinder or electric motor actuators.

Val-Matic control systems provide reliable power and control of hydraulic actuated butterfly valves. Val-Matic control panels use the highest quality components and provide field adjustable operation of valves. Oil accumulator systems provide hydraulic power for valves even after power failure. Electrical panels provide for remote monitoring of valve operation and alarm conditions.

TRAVELING NUT ACTUATORS



- Manufactured in accordance w/AWWA C504
- Externally Adjustable Stops Rated to 450 Ft-Lbs
- External Indication of Valve Position
- Stainless Steel External Stop Bolts
- Centralizing ACME Thread for High Efficiency
- FA10 Motor Mounting Flange for Ease of Automation

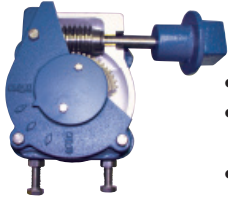

WORM GEAR MANUAL ACTUATORS

- Manufactured in accordance w/AWWA C504
- Externally Adjustable Mechanical Stops Rated to 300 Ft-Lbs
- External Indication of Valve Position
- Bronze Radial Bearings
- Available for Above Ground, Buried Service and Submerged Applications



AIR, OIL AND WATER CYLINDER ACTUATORS

- Manufactured in accordance w/AWWA C541
- Various Operating Times
- Available with Non-Intrusive Enclosure
- Electric Power - 3PH, 1PH and DC Motors
- Adjustable Limit and Torque Switches
- Open/Close, Modulating and Throttling



ELECTRIC MOTOR ACTUATORS

- Manufactured in accordance w/AWWA C542
- Cylinder Bore Sizes Up to 24"
- Suitable for Air, Oil and Water Supply Media Up to 150 psig
- Available with Declutchable Hand Wheel Overrides
- Cylinder Available in All Stainless Steel and Non-Metallic Construction

CONTROL SYSTEMS



OIL ACCUMULATOR SYSTEMS

- Size Range: 80-400 Gallon Capacity
- Pressure Range: Up to 125 PSI
- Equipped with Electrical Control Panels
- Compact Skid Design



HYDRAULIC CONTROL PANELS

- NEMA 4X Waterproof and Corrosion Resistant Enclosures
- Supply Line with Isolation Valve and Pressure Gauge
- Corrosion Resistant Piping
- Reliable Brass Solenoid Valves and Multi-Turn Flow Control Valves



ELECTRIC CONTROL PANELS

- NEMA 4X Waterproof and Corrosion Resistant Enclosures
- Plug-In Control Relays
- Emergency Stop Alarm Circuit
- Heavy-Duty Switches and Transformer Pilot Lights

Installation Dimensions

FLANGED END CONNECTION

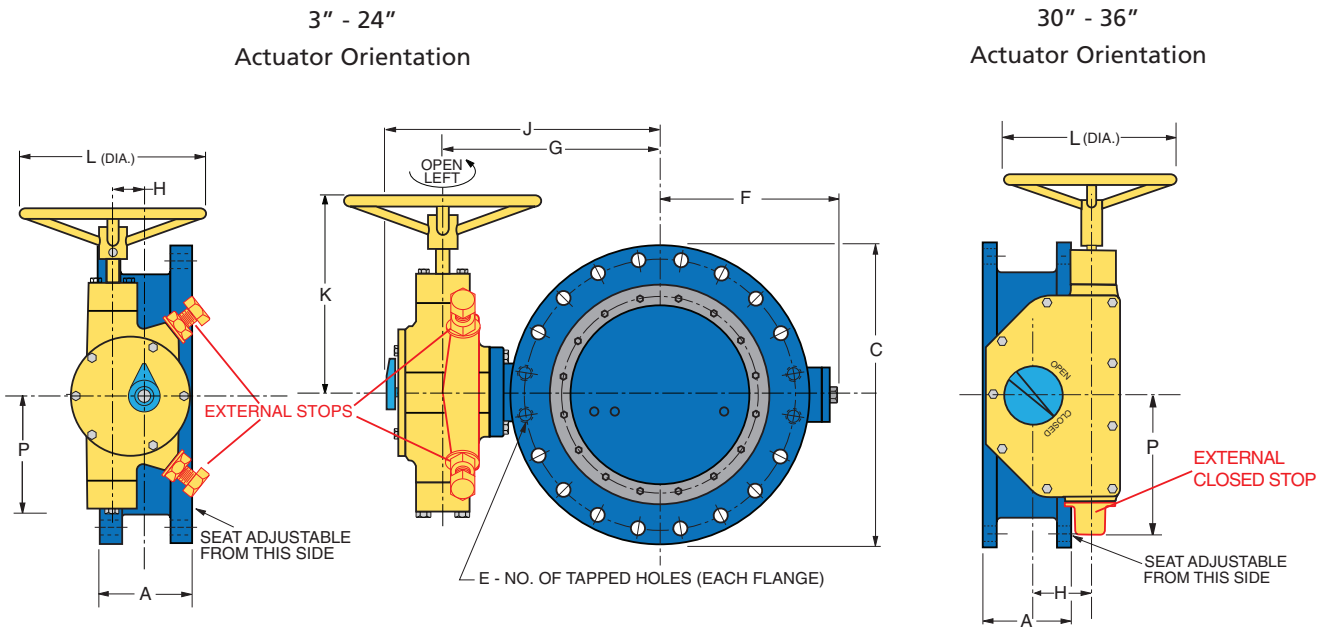

Note: End Flanges Conform to ANSI B16.1 Class 125 or 250

Dimensions in Inches														
Valve Size	Pressure Class	A	C	E	F	G	H	J	K	L	P	Turns to Open	Actuator Size	Weight
3	150B	5.00	7.50	4	6.00	7.44	1.50	10.12	9.38	8	5.65	15	LS-1A	63
	250B	5.62	8.25	8										71
4	150B	5.00	9.00	0	6.00	7.44	1.50	10.12	9.38	8	5.65	15	LS-1A	71
	250B	5.62	10.00											90
6	150B	5.00	11.00	4	7.00	8.12	1.50	10.81	9.38	8	5.65	15	LS-1.2A	92
	250B	5.88	12.50			8.44		11.06						128
8	150B	6.00	13.50	0	8.00	9.12	1.50	11.75	9.38	8	5.65	15	LS-1.2A	128
	250B	7.00	15.00			4		9.69						12.31
10	150B	8.00	16.00	0	10.00	11.50	2.00	14.31	10.38	12	6.50	20	LS-2A	194
	250B	9.38	17.50											273
12	150B	8.00	19.00	0	11.06	12.56	2.00	15.38	10.38	16	6.50	20	LS-2A	270
	250B	9.50	20.50			12.81		15.63						376
14	150B	8.00	21.00	0	13.50	15.62	3.50	19.19	19.12	24	9.15	35	LS-3A	383
	250B	9.50	23.00											4
16	150B	8.00	23.50	0	14.62	16.69	3.50	20.19	19.12	24	9.15	35	LS-3A	477
	250B	9.62	25.50											4
18	150B	8.00	25.00	4	15.50	17.94	5.00	21.50	20.88	24	10.80	50	LS-4A	636
	250B	9.62	28.00											866
20	150B	8.00	27.50	4	17.50	19.94	5.00	23.50	20.88	24	10.80	50	LS-4A	746
	250B	9.62	30.50											1024
24	150B	8.00	32.00	4	20.50	22.94	5.00	26.50	20.88	24	10.80	50	LS-4A	1088
	250B	9.75	36.00						22.38					30
30	150B	12.00	38.75	4	27.40	29.40	8.50	35.20	29.56	24.00	17.80	60	LS-5A	2370
	250B	13.75	43.00											2713
36	150B	12.00	46.00	4	29.50	32.12	8.50	37.94	29.56	24.00	17.80	60	LS-5A	3425
	250B	14.00	50.00											3980

Installation Dimensions

FLANGED END CONNECTION

42" - 90"
Actuator Orientation

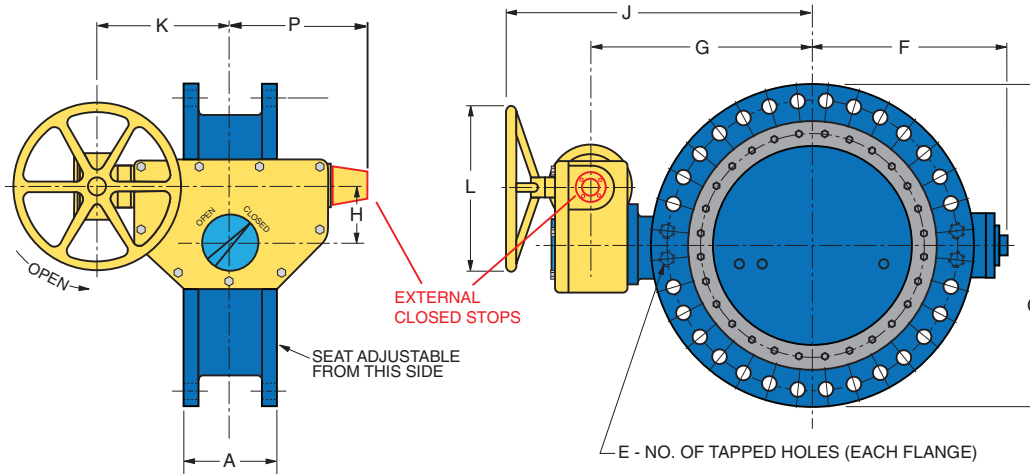

96" - 120"
Actuator Orientation

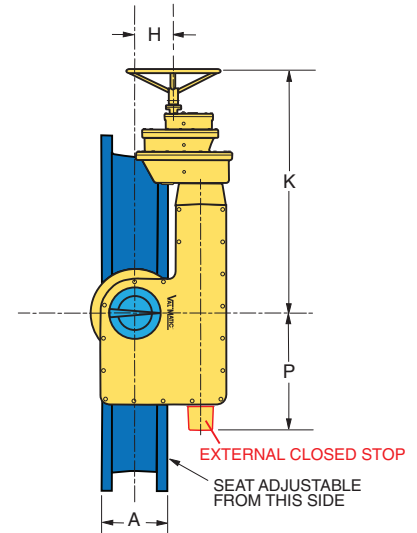

Note: End Flanges Conform to ANSI B16.1 Class 125 or 250

Dimensions in Inches														
Valve Size	Pressure Class	A	C	E	F	G	H	J	K	L	P	Turns to Open	Actuator Size	Weight
42	150B	12.00	53.00	4	35.25	35.88	8.50	49.50	20.13	24.00	17.75	178	LS-5.2A	4559
	250B	14.12	57.00											5489
48	150B	15.00	59.50	4	39.31	41.44	10.50	57.75	24.94	24.00	21.88	276	LS-6A	6950
	250B	17.50	65.00											8510
54	150B	15.00	66.25	8	44.25	45.44	10.50	61.75	24.94	24.00	21.88	276	LS-6A	9280
	250B													
60	150B	15.00	73.00	8	48.25	51.88	10.50	70.12	24.94	24.00	21.88	276	LS-6A	12900
	250B													
66	150B	18.00	80.00	8	53.31	58.12	10.50	76.38	24.94	24.00	21.88	276	LS-6A	14840
	250B													
72	150B	18.00	86.50	8	59.00	61.00	14.00	79.25	32.25	24.00	28.75	547	LS-7A	17840
	250B													
78	150B	18.00	93.00	8	54.50	73.63	14.00	94.38	32.25	24.00	28.75	547	LS-7.3A	14040
84	150B	19.00	99.75	8	58.75	76.25	14.00	98.50	32.25	30.00	28.75	547	LS-7.2A	16440
	250B	24.00	99.75	8	71.25	71.62	14.00	79.88	32.25	24.00	28.75	547	LS-7.2A	27060
90	150B	20.00	106.50	8	62.88	82.50	14.00	105.75	32.25	36.00	28.75	547	LS-7A	19740
96	150B	21.00	113.25	8	68.50	73.30	12.30	88.30	54.20	30.00	37.30	1750	LSG-8A	27400
102	150B	24.00	120.00	8	71.70	77.40	12.30	92.40	54.20	30.00	37.30	1750	LSG-8A	31100
108	150B	24.00	126.75	8	75.38	82.30	12.30	97.30	55.70	30.00	37.30	1750	LSG-8A	35000
120	150B	26.00	140.75	8	83.30	89.20	12.30	104.20	57.10	30.00	37.30	1750	LSG-8A	47400

Installation Dimensions

MECHANICAL JOINT END CONNECTION

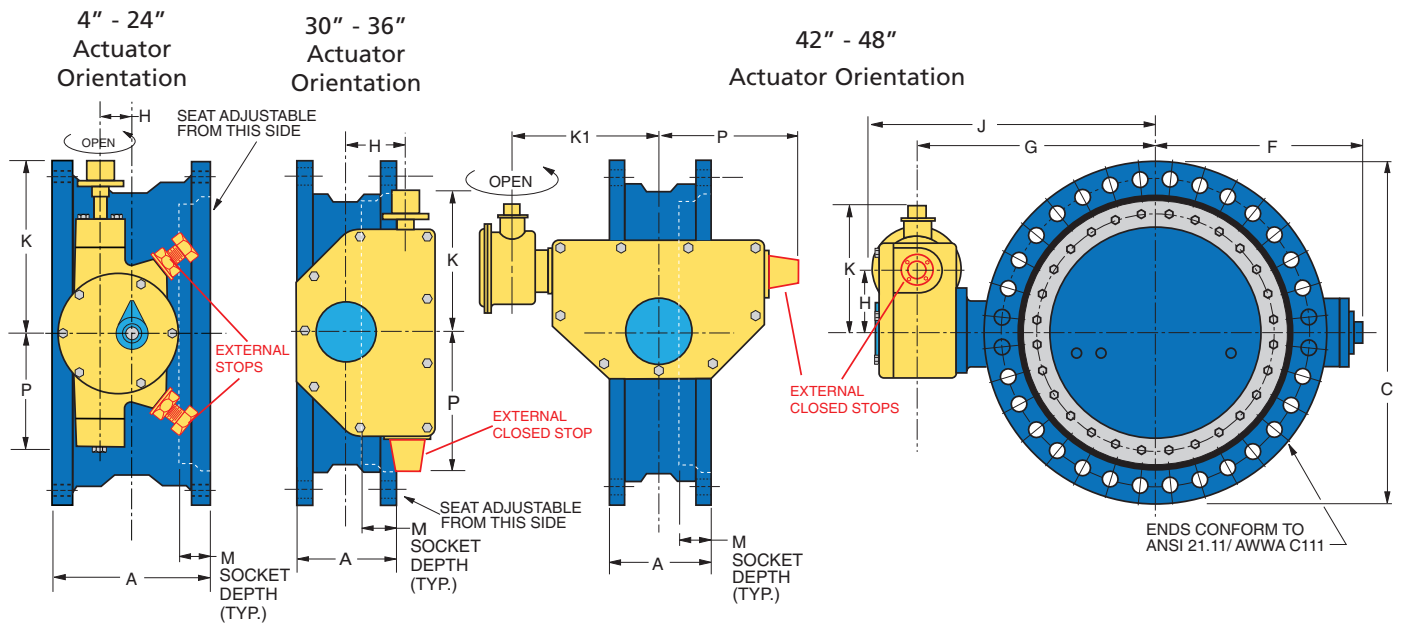

Dimensions in Inches													
Valve Size	Pressure Class	A	C	F	G	H	J	K	K1	M	P	Actuator Size	Weight
4	150B	7.50	9.13	6.00	7.46	1.50	9.96	7.83	-	2.50	5.65	LS-1A	90
	250B												
6	150B	8.00	11.13	7.03	8.15	1.50	10.65	7.83	-	2.50	5.65	LS-1.2A	135
	250B												
8	150B	8.25	13.38	8.00	9.13	1.50	11.63	7.83	-	2.50	5.65	LS-1.2A	190
	250B												
10	150B	8.88	15.69	10.00	11.50	2.00	14.19	8.71	-	2.50	6.50	LS-2A	265
	250B												
12	150B	10.00	17.94	11.06	12.56	2.00	15.25	8.71	-	2.50	6.50	LS-2A	345
	250B												
14	150B	13.00	20.31	13.50	15.65	3.50	19.03	12.06	-	3.50	9.15	LS-3A	560
	250B												
16	150B	14.00	22.56	14.63	16.69	3.50	20.06	12.06	-	3.50	9.15	LS-3A	670
	250B												
18	150B	14.13	24.81	15.50	17.94	5.00	21.38	13.81	-	3.50	10.80	LS-4A	875
	250B												
20	150B	14.00	27.13	17.50	19.94	5.00	23.38	13.81	-	3.50	10.80	LS-4A	1070
	250B												
24	150B	15.63	31.56	20.50	22.94	5.00	26.38	13.81	-	3.50	10.80	LS-4A	1395
	250B												
30	150B	18.13	39.13	27.38	29.18	8.50	35.00	19.50	-	4.00	17.75	LS-5A	2480
	250B												
36	150B	19.25	46.00	29.50	31.88	8.50	37.75	19.50	-	4.00	17.75	LS-5A	3775
	250B												
42	150B	19.75	53.13	35.25	35.88	8.50	41.75	17.50	19.50	4.00	17.75	LS-5.2A	5800
	250B												
48	150B	21.31	60.00	39.31	41.50	10.50	50.25	22.25	24.88	4.00	21.88	LS-6A	8600
	250B												

Installation Dimensions

FLANGE X MECHANICAL JOINT END CONNECTION

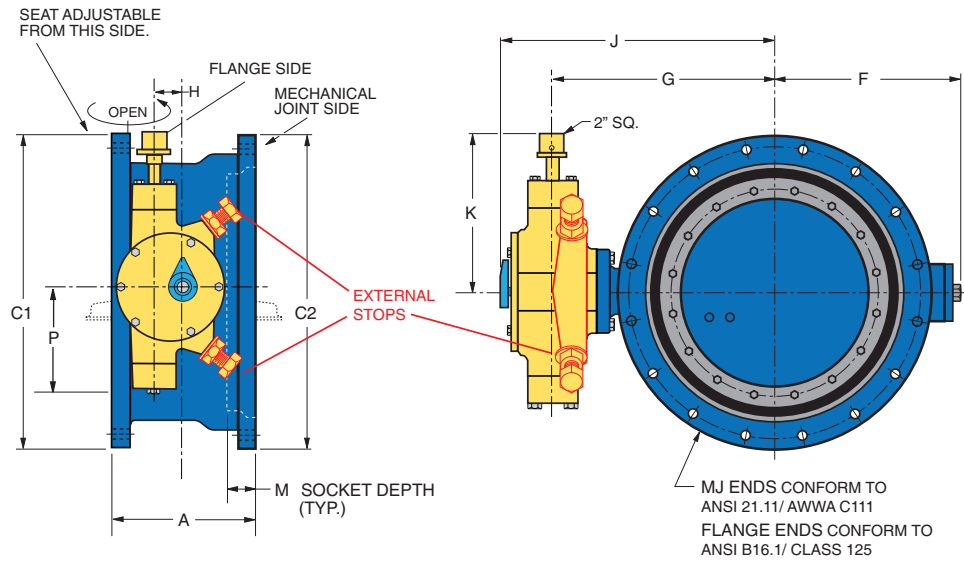

Dimensions in Inches													
Valve Size	Pressure Class	A	C1	C2	F	G	H	J	K	M	P	Actuator Size	Weight
6	150B	6.75	11.00	11.12	7.03	8.15	1.50	10.65	7.83	2.50	5.65	LS-1.2A	110
8	150B	7.50	13.50	13.38	8.00	9.13	1.50	11.63	7.83	2.50	5.65	LS-1.2A	165
12	150B	8.62	19.00	17.94	11.06	12.56	2.00	15.25	8.71	2.50	6.50	LS-2A	300
16	150B	10.00	23.50	22.56	14.62	16.69	3.50	20.06	12.36	3.50	9.15	LS-3A	600

WAFER BODY CONNECTION

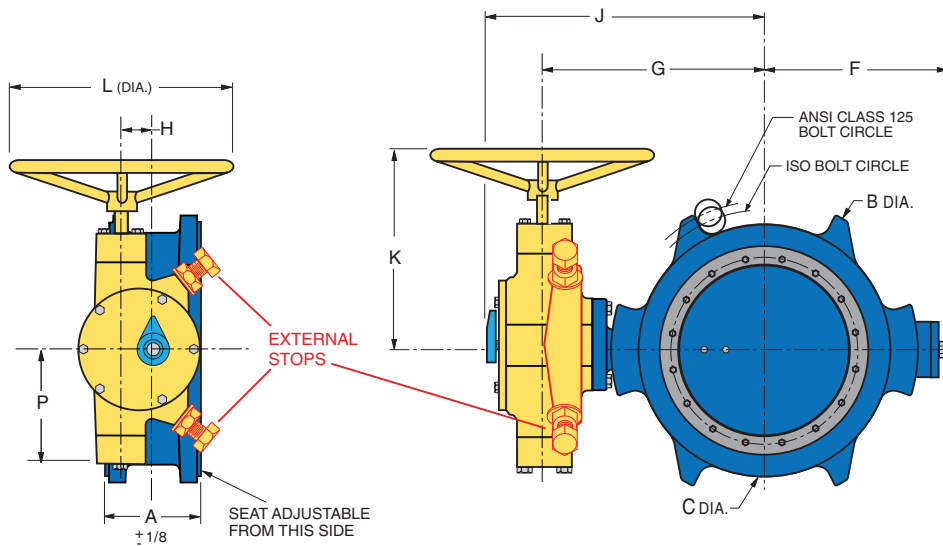

Dimensions in Inches														
Valve Size	Pressure Class	A	B	C	F	G	H	J	K	L	P	Turns to Open	Actuator Size	Weight
4	150B	2.25	7.88	6.41	6.00	7.44	1.50	10.13	9.38	8	5.65	15	LS-1A	48
6	150B	2.81	9.70	8.59	7.00	8.13	1.50	10.81	9.38	8	5.65	15	LS-1.2A	64
8	150B	2.94	12.50	10.75	8.00	9.13	1.50	11.75	9.38	8	5.65	15	LS-1.2A	70
10	150B	3.13	14.75	12.94	10.00	11.50	2.00	14.31	10.38	12	6.50	20	LS-2A	110
12	150B	3.38	17.38	14.88	11.06	12.56	2.00	15.38	10.38	16	6.50	20	LS-2A	125

Installation Dimensions

LUG BODY CONNECTION

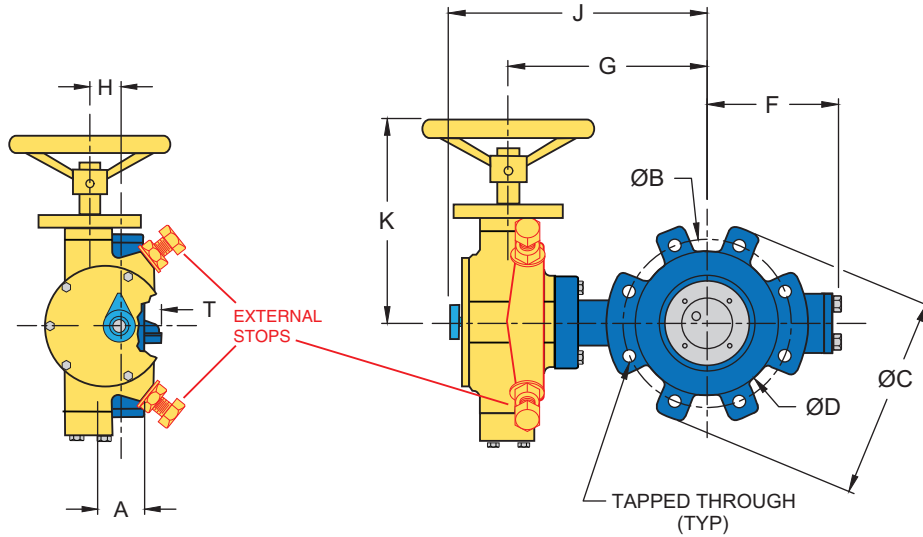

Dimensions in Inches														
Valve Size	Pressure Class	A	B	C	D	F	G	H	J	K	T	Turns to Open	Actuator Size	Wt
4	150B	2.25	7.50	9.00	6.41	6.00	8.90	1.50	11.60	7.83	0.80	15	LS-1A	69
6	150B	2.81	9.50	11.00	8.59	7.00	9.90	1.50	12.60	7.83	1.60	15	LS-1.2A	89
8	150B	2.93	11.75	13.50	10.75	8.00	11.10	1.50	13.80	7.83	2.50	15	LS-1.2A	123
10	150B	3.23	14.25	16.00	12.94	10.00	12.80	2.00	15.60	8.71	3.30	20	LS-2A	175
12	150B	3.55	17.00	19.00	14.88	11.10	14.30	2.00	17.10	8.71	4.20	20	LS-2A	253

Accessories

Space limitations and application specifics often require special accessories. In addition to those shown below, Val-Matic offers a wide range of accessories to meet your application requirements. Please consult factory for assistance.

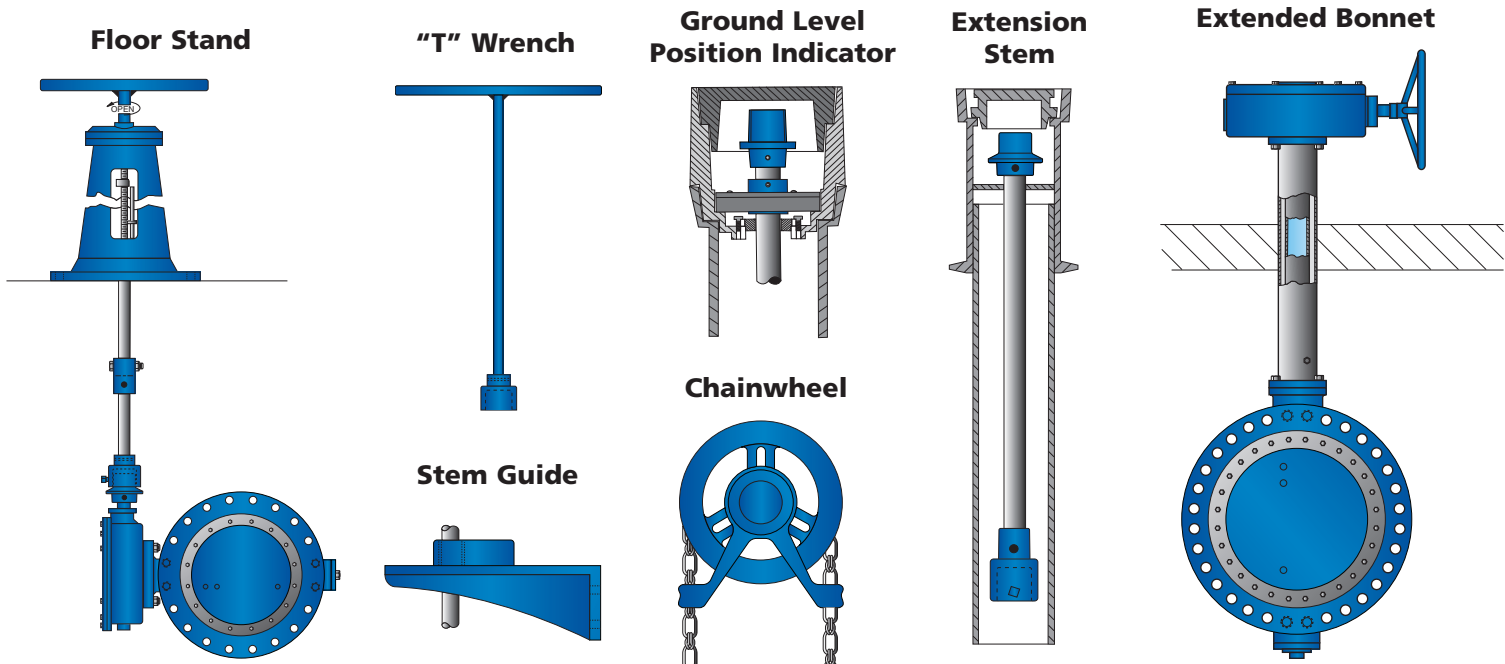

SCOPE

- 1.1 This specification covers the design, manufacture, and testing of AWWA Class 150B (3"-144") and AWWA Class 250B (3"-96") butterfly valves.

STANDARDS AND APPROVALS

- 2.1 The valves shall be designed, manufactured and tested in accordance with American Water Works Association Standard ANSI/AWWA C504 and C516.
- 2.2 The valves shall be certified to NSF/ANSI 61 Drinking Water System Components - Health Effects and certified to be Lead-Free in accordance with NSF/ANSI 372.
- 2.3 Manufacturer shall have a quality management system that is certified to ISO 9001 by an accredited, certifying body.

CONNECTIONS

- 3.1 Flanged end connections shall fully conform with ANSI B16.1 for Class 125, Class 250 iron flanges, or AWWA C207 Class D. Both 125 and 250 flanges shall be flat faced.
- 3.2 Mechanical Joint end connections shall fully conform with ANSI/AWWA C111/A21.11.
- 3.3 Wafer end connections shall be designed for installation between ANSI B16.1 Class 125 iron flanges or between ISO 7005-2 PN10 or PN16 flanges.

DESIGN

- 4.1 The valve shafts shall be of the through-type for sizes 3"-24". 30" and larger shall be of the stub type design. Shafts shall be locked to the disc by O-ring sealed taper pins retained with stainless steel nuts. Through-type shafts shall be supplied on 30" and larger valves when specified.
- 4.2 The valve discs shall be of the solid type without external ribs or vanes to obstruct flow.
- 4.3 Resilient seats shall be located on the valve disc and shall provide a 360° continuous, uninterrupted seating surface. Seats shall be mechanically retained with a stainless steel retaining ring and stainless steel cap screws which shall pass through both the resilient seat and the retaining ring. The retaining ring shall be continuous or investment cast with overlapping sections, serrated grooves, and shoulders providing a Tri-Loc® system. The resilient seat's mating surface shall be to a 360° continuous, uninterrupted stainless steel body seat ring. Resilient seats shall be field adjustable and replaceable without removing the valve from the line and shall not require epoxy, syringes, needles or pressure vessels to replace or adjust.
- 4.4 The sleeve bearings shall be provided in the valve hubs and shall be self-lubricating nylatron or teflon lined, fiberglass backed.
- 4.5 The thrust bearings shall be provided and shall be adjustable on valves 30" and larger.
- 4.6 The shaft seals shall be of the V-type and shall be replaceable without removal of the valve from the line or the shaft from the valve.

MATERIALS

- 5.1 Body: Class 150B valve bodies shall be ASTM A126, Class B gray iron or ASTM A536 Grade 65-45-12 ductile iron. Class 250B valve bodies shall be ASTM A536 Grade 65-45-12 ductile iron.
- 5.2 Disc: Valve disc shall be ASTM A536 Grade 65-45-12 ductile iron.
- 5.3 Shafts: Shafts shall be ASTM A276 type 304, or ASTM A564, Type 630 Stainless Steel.

- 5.4 Seat: Resilient seat shall be Buna-N and mate to a Type 316 Stainless Steel body seat ring.

- 5.5 Hardware: All seat retaining hardware shall be Type 316 stainless steel.

ACTUATION

- 6.1 Manual, electric or cylinder actuation shall be provided as specified.
- 6.2 Manual actuators shall be of the traveling nut design with characterized closure per AWWA C504 and equipped with externally adjustable closed position stops capable of withstanding 450 ft-lbs. Actuators shall be lubricated with EP-2 grease and fully enclosed in an iron housing sealed against the entry of water. Buried service actuators shall be packed with grease and sealed for temporary submergence to 20 feet of water. Exposed input shafts shall be electroless nickel plated or stainless steel.
- 6.3 Cylinder actuators shall be traveling nut design with characterized closure sized to position the valve with an air, water or oil supply pressure of 80-150 psi and built in accordance with AWWA C541. The rotating mechanism will consist of a lever and traveling nut directly connected to the cylinder rod. The cylinder rod, heads and barrel shall be constructed of stainless steel or non-metallic material for water service. Rod and piston seals shall be of the self-adjustable, wear-compensating type. The piston shall be one-piece with a wear strip.
- 6.4 Motor actuators shall be furnished in accordance with AWWA C542 for Power Actuators and factory tested on the production valve. The motor unit shall be mounted to a self-locking traveling nut actuator with characterized closure and externally adjustable closed stop. The motor actuator assembly shall be designed for open/close service with a minimum operating time of 60 sec. The motor unit shall be furnished with a position indicator, independently adjustable, 15-amp limit switches, and adjustable torque sensors to protect the valve indicator. A handwheel with a declutch lever shall be provided so that the handwheel does not rotate during electrical operation. Motors shall be sized with a 1.5 safety factor and a power supply of 230/460V, three phase, 60 Hz AC. Electrical operation shall include Local-Off-Remote selector switch, local Open/Close push buttons and position indication lamps.

OPTIONS

- 7.1 Optional body material is ASTM A536, Grade 65-45-12 ductile iron.
- 7.2 Optional shaft material is ASTM A276, Type 316 stainless steel.
- 7.3 Optional manual actuator for submerged service shall be packed with grease and sealed for continuous submergence to 30 feet of water. All fasteners shall be stainless steel and all the exposed input shafts shall be electroless nickel plated or stainless steel.
- 7.4 Optional resilient seat material is EPDM.

MANUFACTURE

- 8.1 The valve exteriors for above ground service shall be coated with a universal, alkyd primer. Valve exteriors for buried service shall be coated with an epoxy coating. Valve interiors shall be coated with an NSF/ANSI 61 epoxy coating approved for potable water. Fusion bonded epoxy shall be supplied on the exterior and interior when specified.
- 8.2 Butterfly Valves shall be Val-Matic® Series 2000 as manufactured by Val-Matic® Valve & Mfg. Coporation, Elmhurst, IL. USA or approved equal.



Val-Matic's quality of design and meticulous workmanship has set the standards by which all others are measured. Quality design features such as the AWWA **Ener-G® Ball Valve** with its energy efficient design, fusion bonded epoxy and adjustable resilient seating....**Cam-Centric® Plug Valves** have more requested features than any other eccentric plug valve....**American-BFV® Butterfly Valves** include a field replaceable seat without the need for special tools....**Tilted Disc® Check Valves** with high strength and wear resistant aluminum bronze trim as standard....**Silent Check Valves** featuring combined resilient/metal-to-metal seating and are **NSF/ANSI 61 & 372 Certified**....**Sure Seal Foot Valves** provided with a heavy duty stainless steel screened inlet....**Swing-Flex® and Surgebuster® Check Valves** designed with an unrestricted full flow area....**Swing Check Valves** with field

adjustable closure versatility....**Dual Disc® Check Valves** utilizing stabilized components to provide extended life....**Air Release, Air/Vacuum and Combination Air Valves** provided standard with Type 316 stainless steel trim....**VaultSafe®** family of products includes the **FloodSafe® Inflow Preventer, FrostSafe®** two-way damper and the **VentSafe®** vent pipe security cage. The **QuadroSphere® Trunnion Ball Valve** features a unique ball design with recessed surfaces creating additional flow paths to provide a self-cleaning action and reduced wear and torque.

Val-Matic is totally committed to providing the highest quality valves and outstanding service to our customers. Complete customer satisfaction is our goal. **Make the change to quality, specify Val-Matic!**



VAL-MATIC® *Your Valve Experts™*

Val-Matic Valve and Manufacturing Corp.
 905 Riverside Drive, Elmhurst, IL 60126
 Phone: 630-941-7600 • Fax: 630-941-8042
 www.valmatic.com • valves@valmatic.com

Copyright © 2021 Val-Matic Valve & Mfg. Corp.
 ISO 9001:2015 certified company 8/21