

Bettis RGS F-Series Double-Acting Actuators

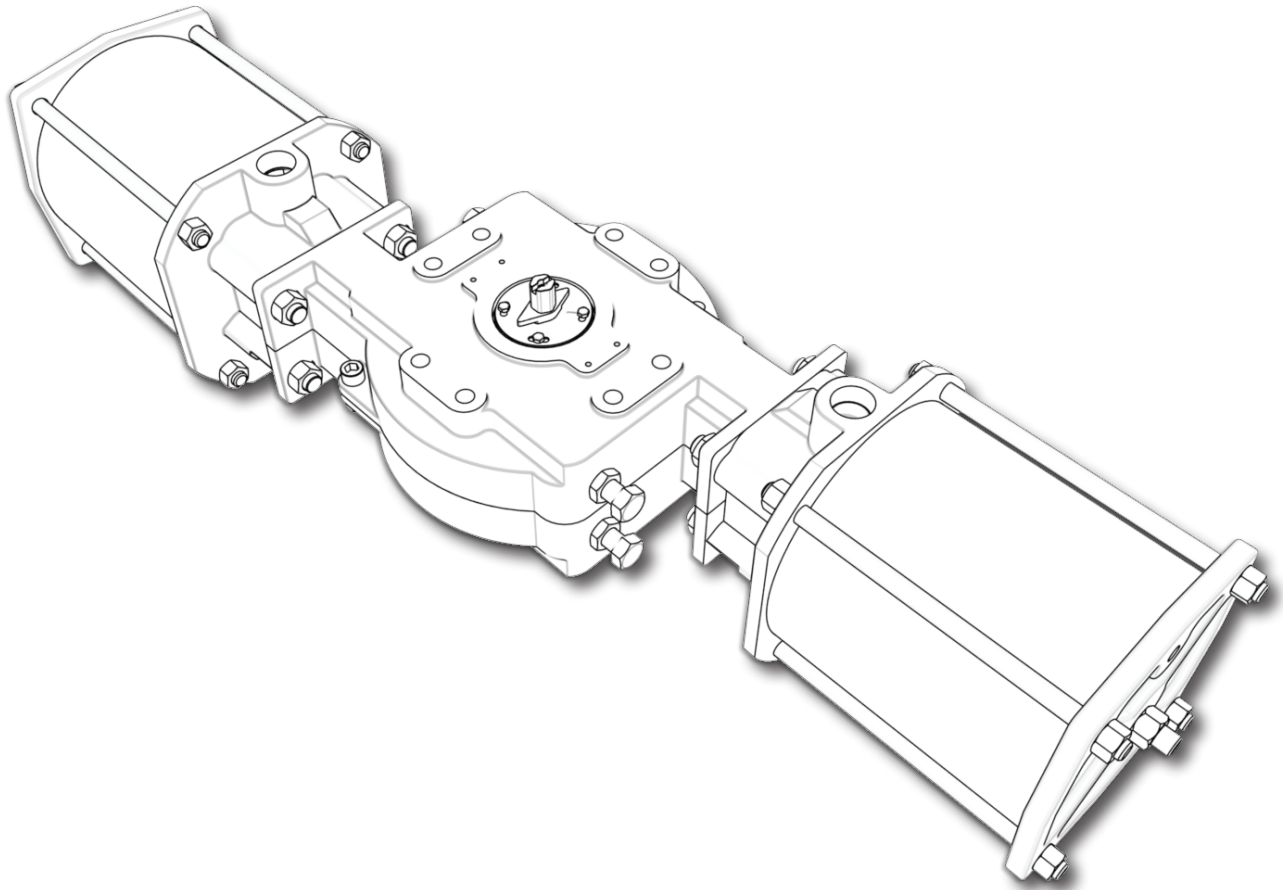

Table of Contents

Section 1: Overview	1
Section 2: Installation	2
2.1 Valve Attachment	3
2.2 Accessory Mounting	4
2.3 Piping and Operation.....	4
2.4 Travel Adjustment.....	7
Section 3: Troubleshooting	9
Section 4: Maintenance	10
4.1 Periodic Maintenance Schedule	10
4.2 Lubrication.....	10
4.3 Piston Seal Replacement.....	10
4.4 Rod Seal Replacement	13
4.5 Yoke Seal and Bushing Replacement.....	15
4.6 Pins and Rollers Replacement	19
Appendix A:	21
A.1 Force Module	21
A.2 Torque Module	23

Section 1: Overview

NOTE:

All activities must be carried out in order to ensure proper actuator operation. Always read all instructions before beginning maintenance.

Bettis RGS F-Series actuators are composed of three basic sub-assemblies, two force modules and a torque module. The force modules contain the pistons which provide linear motion. The torque module contains the yoke which converts the force modules' linear motion into torque and operates the valve.

Every actuator assembled by Bettis is tested prior to shipment to our customers. Order specific documentation may be available upon request.

Section 2: Installation

Bettis actuators may be mounted in any position/orientation. If necessary, lift the actuator with straps placed inside the framework of the body. Never lift the actuator by the cylinders, tie rods, or travel stops. Lifting the actuator with the valve attached is not generally recommended.

Figure 1

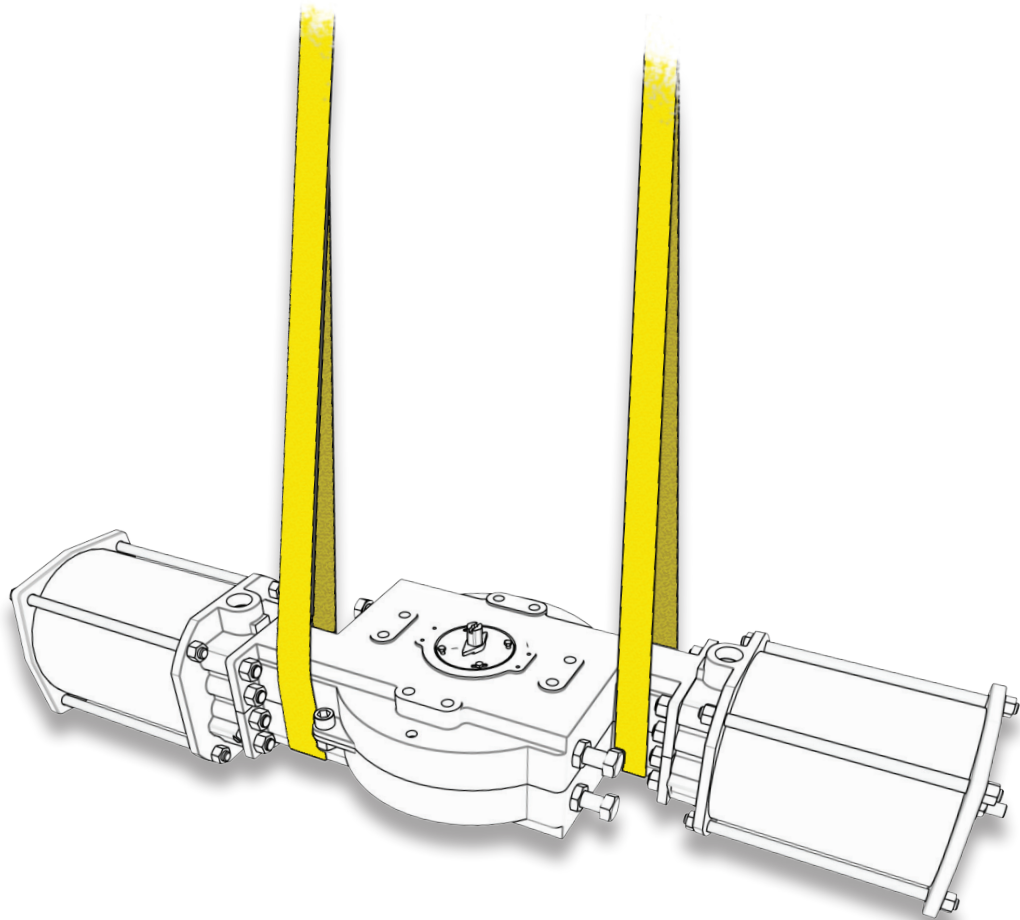

Larger sizes have lifting eyes incorporated into their body section which may be used to lift the actuator.

Figure 2

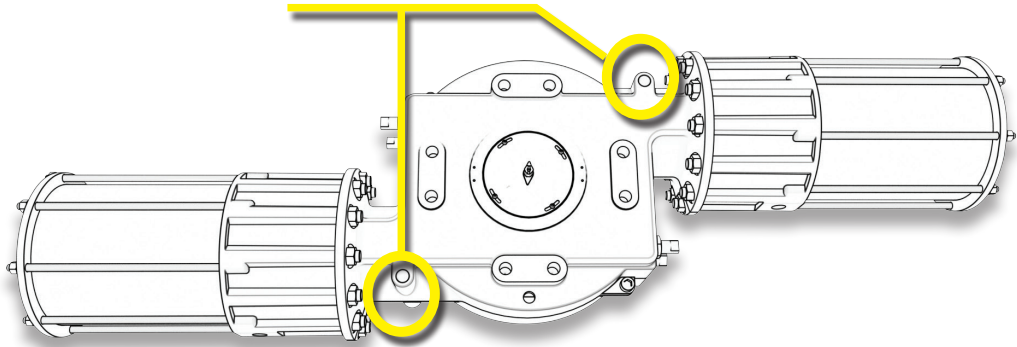

2.1 Valve Attachment

NOTE:

Prior to mounting the actuator, verify alignment of coupler and shaft to ensure that the valve will move to correct position.

Ensure the actuator is in the same position as the valve. It may be necessary to stroke the actuator to determine the correct mounting orientation. Attach the actuator to the valve using the proper bracket and coupler, or with a Bettis Universal Mounting Plate (UMP) if provided. Using all mounting holes indicated on Bettis dimensional drawings, tighten all fasteners hand tight then torque the fasteners to the corresponding value on the table below.

Table 1.

	Thread Pattern	Ft-Lbs	Nm
Accessories	M5	3.4	4.6
F2200	M12	49	66
F2250/2300	M16	120	162
F2375	M20	235	318
F2488	M24	400	543
F2575	M30	800	1084

2.2 Accessory Mounting

As a standard, Bettis RGS F-Series actuators are provided with female 4mm slotted accessory mounting geometry. When installing accessories, such as switch boxes or positioners, tighten accessory mounting bolts hand tight, stroke the actuator three times to ensure proper alignment then tighten the accessory mounting bolts to the proper torque. Check the dimensional drawing or associated product bulletin for exact dimensions.

2.3 Piping and Operation

The operation of a Bettis RGS F-Series Double-Acting (DA) actuator is comparable to any double-acting scotch yoke actuator.

Instrument air, water, and other power gases and fluids may be used to cycle the actuator so long as construction materials were chosen accordingly and maximum allowable pressure is not exceeded. Air driven stainless-steel actuators with stainless-steel or composite cylinders are not harmed by wet air (so long as freezing does not occur). Aluminum and chrome-plated steel cylinders may be harmed over time by the presence of water.

⚠ WARNING: DO NOT EXCEED PRESSURE RATING

Exceeding the stated maximum pressure may result in damage to equipment and danger to personnel including severe injury or death. Consult the actuator label for operating limits. If an actuator label is missing, contact Bettis to request a replacement.

⚠ WARNING: DO NOT EXCEED TEMPERATURE RATING

Operating outside of the minimum and maximum temperature range may result in damage to equipment and danger to personnel including severe injury or death. Consult the actuator label for operating limits. If an actuator label is missing, contact Bettis to request a replacement. An example of an actuator label is provided below for your reference.

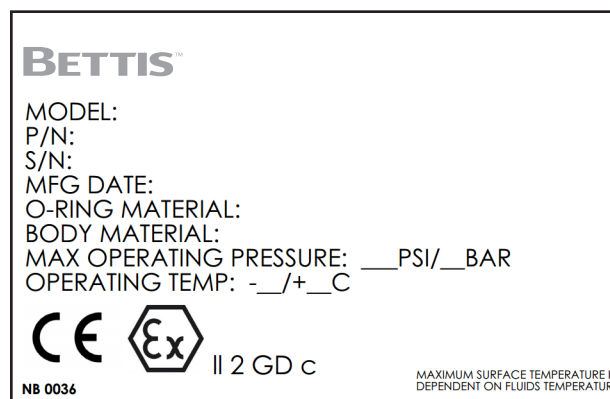

NOTE:

CE marking indicates product conforms to the requirements of applicable directives as listed on the actuator label.

All Bettis actuators are shipped in the Left-Hand orientation unless ordered as Right-Hand. The orientation may be reversed in the field by moving all accessories to the opposite side of the shaft and turning the actuator top-side down.

Double-Acting (Left-Hand): pressure on the end cap ports pushes the pistons inward and causes counterclockwise rotation. Pressure to the base plate ports pushes the pistons outward resulting in a clockwise rotation.

Double-Acting (Right-Hand): pressure on the end cap ports pushes the pistons inward and causes clockwise rotation. Pressure to the base plate ports pushes the pistons outward resulting in a counterclockwise rotation.

Figure 3

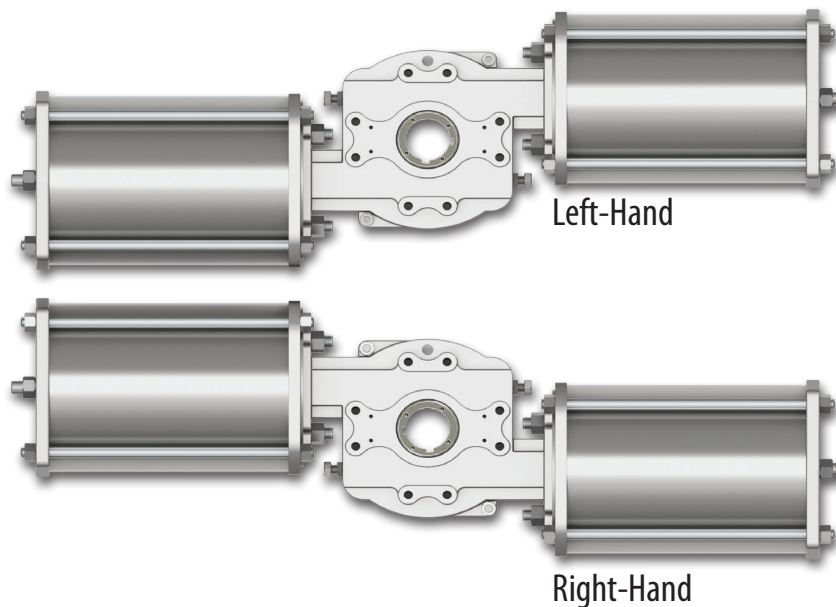

Piping Guidelines:

- Both end cap pressure ports (P1 and P2) and both base plate pressure ports (P3 and P4) must be utilized for proper operation.
- P1 and P2 are typically connected and powered by a single air pathway.
- P3 and P4 are typically connected and powered by a single air pathway.
- P5 is a breather port that should be fitted with a filter or strainer.
- On double-acting models, P5 may also be plugged without affecting actuator operation.

Figure 4

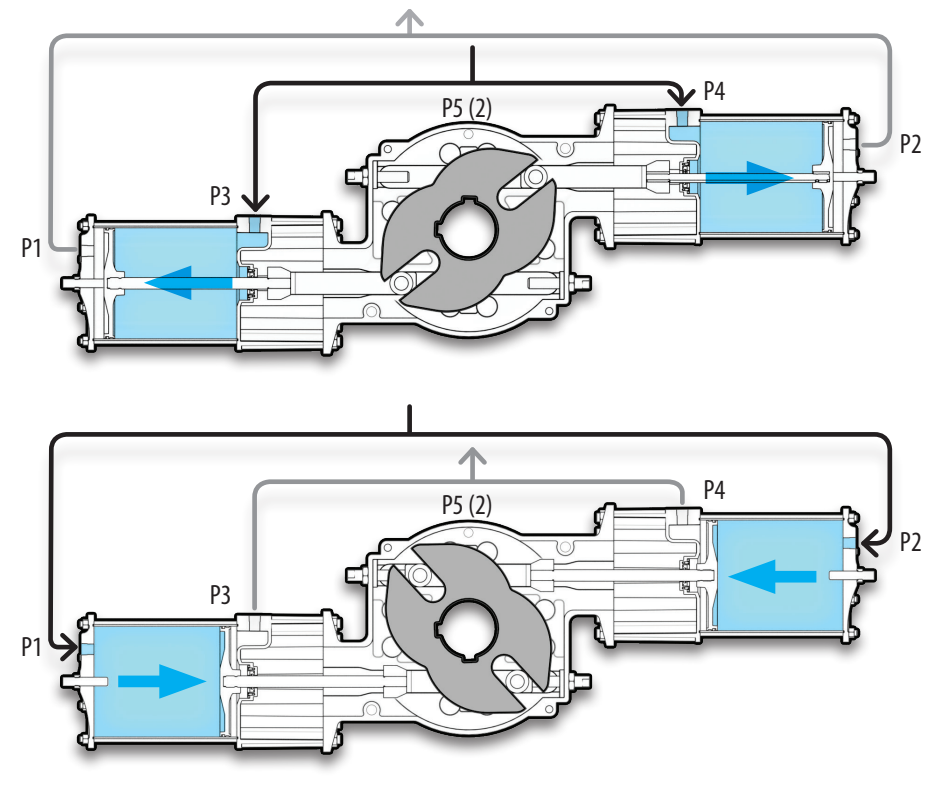

2.4 Travel Adjustment

The following instructions are for Left-Hand orientated actuators. For non-standard models, clockwise and counterclockwise motion will be the inverse of what is described below. Check the actuator model and orientation before adjusting the Travel Stops.

Figure 5

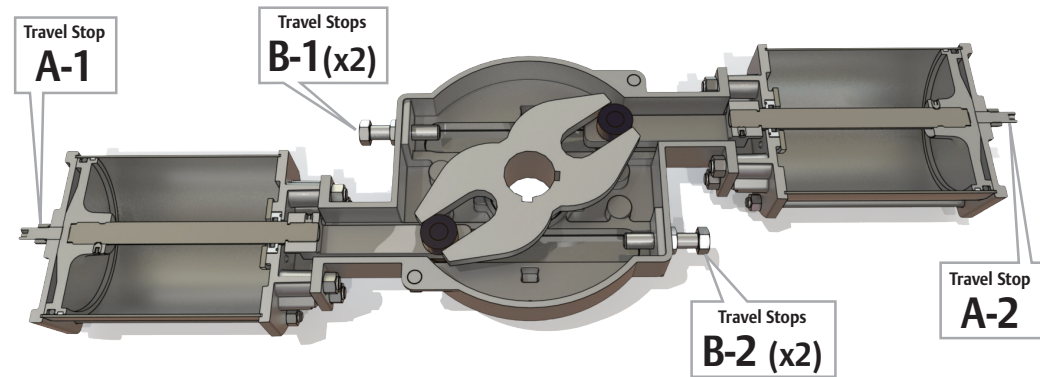

Set Clockwise Rotation (Travel Stops A)

1. Relieve all pressure from the actuator.
2. Loosen the Travel Stop nuts on Travel Stops A-1 and A-2. Be careful not to misplace the travel stop O-rings.
3. Ensure actuator lockout (if provided) is disengaged.
4. Apply pressure to P3 and P4 to force the pistons fully outward, then relieve all pressure.
5. Unthread Travel Stop A-2 four to five full turns.*
6. Adjust Travel Stop A-1 until travel is set to the desired position. It may be necessary to apply pressure to P3 and P4 between adjustments to determine final position of travel.
7. Apply pressure to P3 and P4 and thread Travel Stop A-2 in until it is in firm contact with the piston.
8. With pressure still applied to P3 and P4, tighten both travel stop nuts on Travel Stops A until they are in contact with the end cap, then tighten an additional 1/4 turn.

***Clockwise rotation of the travel stops will shorten actuator stroke, counterclockwise rotation will lengthen actuator stroke.**

Set Counterclockwise Rotation (Travel Stops B)

1. Relieve all pressure from the actuator.
2. Loosen travel stop nuts on Travel Stops B.
3. Ensure actuator lockout (if provided) is disengaged.
4. Unthread Travel Stops B-1 and B-2 four to five full turns each. *
5. Adjust both B-1 travel stops until they contact the clevis simultaneously. It will be necessary to apply pressure to P1 and P2 between adjustments to determine the final position of travel.
6. With pressure to P1 and P2, thread in Travel Stops B-2 until they are in firm contact with the clevis.

Figure 6

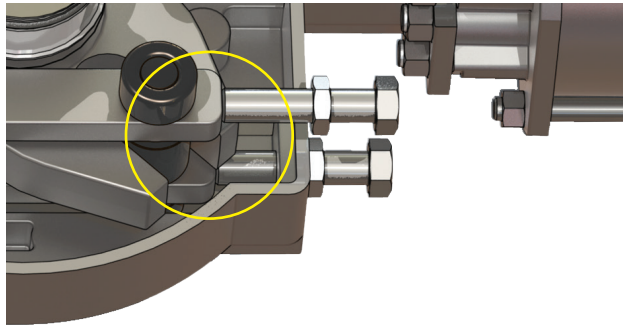

7. With pressure still to P1 and P2 ensure that all Travel Stops B are in firm contact with the clevis and tighten all travel stop nuts until they are in contact with the body, then tighten an additional 1/4 turn.

***Clockwise rotation of the travel stops will shorten actuator stroke, counterclockwise rotation will lengthen actuator stroke.**

Section 3: Troubleshooting

⚠ WARNING: DEPRESSURIZE COMPONENTS PROPERLY

Do not remove/loosen tie rod nuts unless cylinder is fully depressurized. Components may exit the actuator dangerously if disassembly is attempted under pressure.

Ensure that all process lines are safe.

Read all maintenance instructions before starting work.

Table 2.

ISSUE	CAUSE	SOLUTION
Irregular or Stuttering Stroke	Supply pressure too low	Verify operating pressure is correct
	Worn internal components	See Section 4.3 to 4.6
	Damaged or valve	Consult valve manufacturer
Leakage	Travel stop nut is not tight	Tighten travel stop nut with pressure relieved from actuator
	Damaged Piston O-ring	See Section 4.3
	Damaged cylinder seals	See Section 4.3
Improper Travel	Travel stops are not correctly set	See Section 2.4
	Internal cylinder contaminants preventing normal stroke	See Section 4.3
	Damaged valve	Consult valve manufacturer
Operating/Stroking too slowly	Supply pressure too low	Verify operating pressure will supply torque needed to operate valve correctly
	Internal cylinder contaminants preventing normal stroke	See Section 4.3
	Damaged valve	Consult valve manufacturer
	Damaged seals or O-rings causing loss of pressure	See Sections 4.3 to 4.6
	Damaged supply lines	Inspect supply and lines replace as needed
	Limitation of accessories or port size	Upgrade accessories or port size

NOTE:

Performing piston seal replacement on one cylinder at a time will allow maintenance while retaining travel stop adjustment. If both cylinders will be removed at the same time, the travel stops must be fully unthreaded prior to removing the end caps. Leaving the travel stops in place will put spring pressure on the end cap when it is removed, which could cause serious injury or death.

Section 4: Maintenance

4.1 Periodic Maintenance Schedule

General service actuators do not require periodic maintenance. Severe service actuators may require periodic maintenance based on operating conditions. Severe service may include but is not limited to high speed, high cycle, highly corrosive, explosive atmosphere, and others. Special applications may require individual maintenance schedules. Contact Bettis for help developing a maintenance schedule for your application.

NOTE:

This product is only intended for use in large-scale fixed installations excluded from the scope of Directive 2011/65/EU on the restriction of the use of certain hazardous substances in electrical and electronic equipment (RoHS 2).

4.2 Lubrication

Bettis actuators are lubricated for life. For special applications, grease fittings may be provided. Use the grease fittings (if applicable) incorporated into the torque module of your actuator to apply additional lubricant. The frequency of this lubrication will depend on the application of the actuator. For any questions regarding the frequency of this operation or appropriate lubrication compounds, contact your Bettis distributor.

4.3 Piston Seal Replacement

1. Exhaust all pressure and disconnect all supply lines.
2. Loosen all tie rod nuts until they are flush with the ends of the tie rods.
3. Check that there is no pressure against the end cap by verifying that the end cap is not being forced against the tie rod nuts.

⚠ WARNING: EXHAUST ALL PRESSURE AGAINST END CAP

If there is force against the end cap, stop. Do not continue further until it is assured that the unit is safe to disassemble.

4. Remove the end cap. Be careful not to lose the cylinder seal located on the internal side of the end cap.

Figure 7

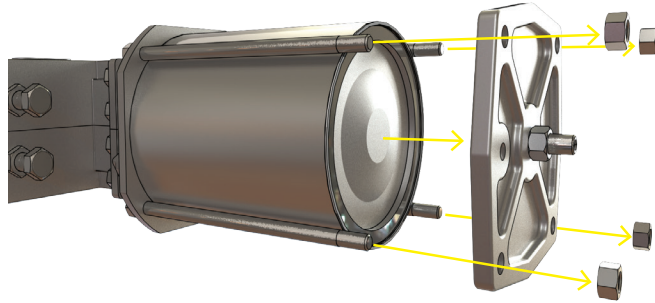

5. Remove the cylinder. Be careful not to damage the internal surface of the cylinder as this will compromise the piston's ability to seal.
6. Replace the piston O-ring and wiper ring as needed. Be sure to lubricate the new O-ring and wiper ring with the correct Bettis approved lubricant if they are replaced.
7. Inspect the piston bolt for any corrosion or wear (pitting, cracking). If excessive corrosion or wear is apparent, a new actuator or actuator components may be necessary.

Figure 8

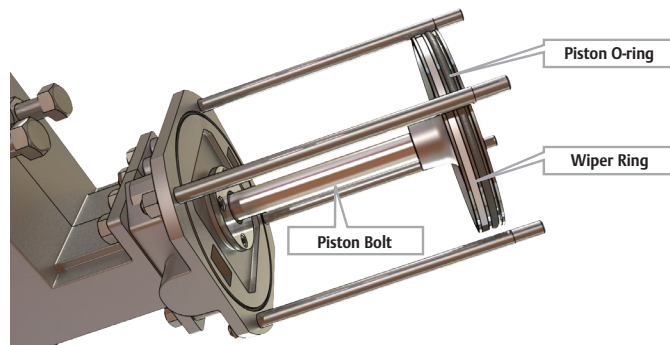

8. Lubricate the internal surface of the cylinder with a light coat of the correct Bettis approved lubricant and slide the cylinder back over the piston and into the cylinder seal groove of the base plate, taking care not to pinch the piston O-ring.
9. Place the end cap back over the tie rods. Be sure that the cylinder is seated in the cylinder seal groove of the end cap with the cylinder seal still in place between the cylinder and the end cap.

10. Secure the end cap with the tie rod hex nuts you removed in step two. Hand tighten, and then torque the hex nuts to half and then full values according to the table below using the pattern designated.

Table 3.

Cylinder Size (In)	Ft-Lbs	Nm
6	15	20
8	35	48
10	35	48
12	35	48
16	56	76
20	58	79
24	87	118

Figure 9

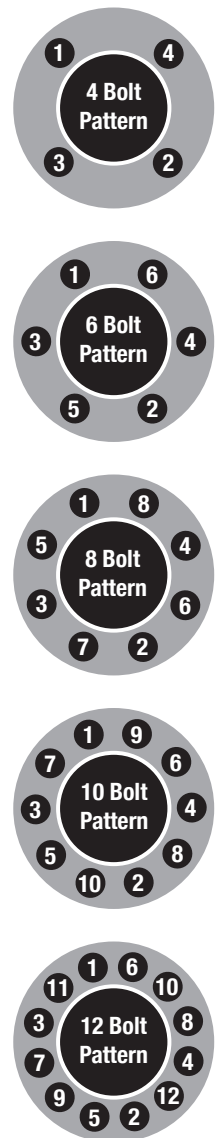

11. Complete steps 1 to 10 on the second force module of the actuator.
12. Leak Test.
13. Reinstall the actuator to service.

4.4 Rod Seal Replacement

1. Follow steps 1 to 4 of Section 4.3.
2. Apply heat to piston hub and set screw to break thread locker, and remove set screw.

Figure 10

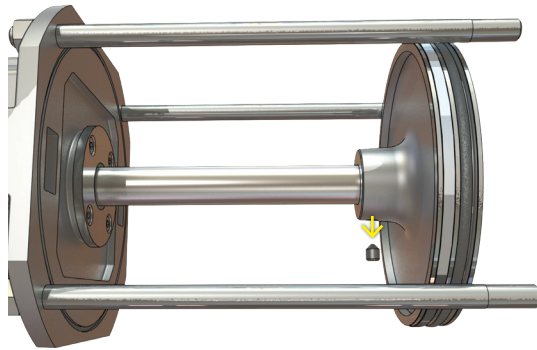

3. Unthread the piston from the piston bolt.

Figure 11

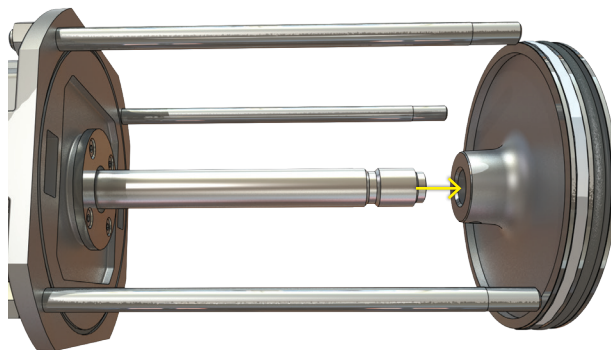

4. Use heat to break thread locker. Remove all socket head cap screws (SHCS) securing the seal retainer to the base plate and slide the seal retainer off the open end of the piston bolt.

5. Remove the seal retainer and seal carrier.

Figure 12

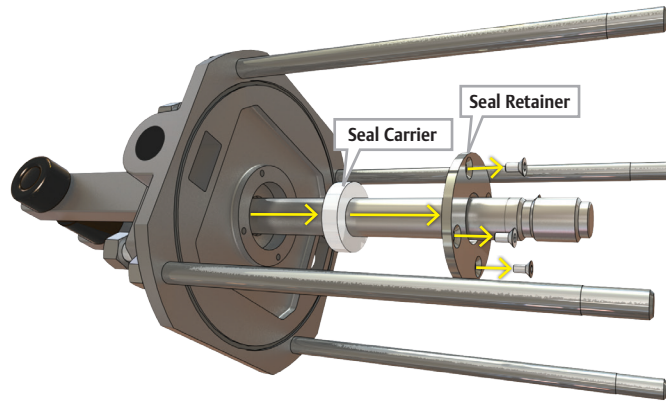

6. Lubricate the new seal carrier, piston bolt, the internal and external seal carrier O-rings.
7. Place the internal and external seal carrier O-rings in their respective grooves on the seal carrier.
8. Slide the seal carrier back over the open end of the piston bolt with the external seal carrier O-ring facing the base plate. Be careful not to damage the internal seal carrier O-ring on the threads of the piston bolt.
9. Secure the seal carrier with the seal retainer and the socket head cap screws removed in step four. Apply medium strength thread locker and torque to 44 in-lb (5 Nm).
10. Apply medium strength thread locker to the internal threads of the piston and thread the piston back onto the piston bolt to the point of refusal.
11. Apply medium strength thread locker to the piston set screw and thread the set screw into the neck of the piston. Torque the set screw to the corresponding value in the table below.

Table 4.

Piston Size (In)	Ft-Lbs	Nm
6	14	18
8, 10, 12, 16	28	37
20, 24	47	65

12. Follow steps 8 to 10 of Section 4.3.
13. Repeat steps 1 to 12 of this section on the second force module.

4.5 Yoke Seal and Bushing Replacement

In Bettis RGS F-Series actuators, the yoke seal does not serve any purpose other than to prevent external contaminants from entering the torque module. The following steps can be followed to replace the yoke seal and/or bushings.

1. Depressurize the actuator and remove all supply lines.
2. Remove the actuator from the valve.
3. Ensure lockout (if provided) is disengaged.
4. Remove the hex nuts which secure the force modules to the torque module of the actuator. Do this for both force modules.

Figure 13

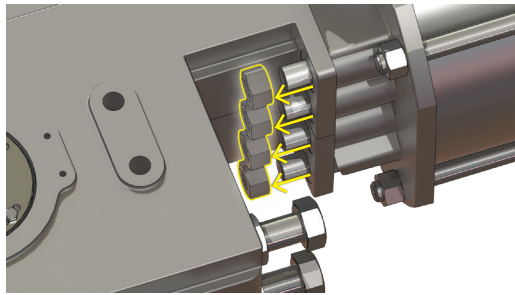

5. Separate the force modules from the torque module. This can be done by simply pulling the force modules away from the torque module simultaneously.

Figure 14

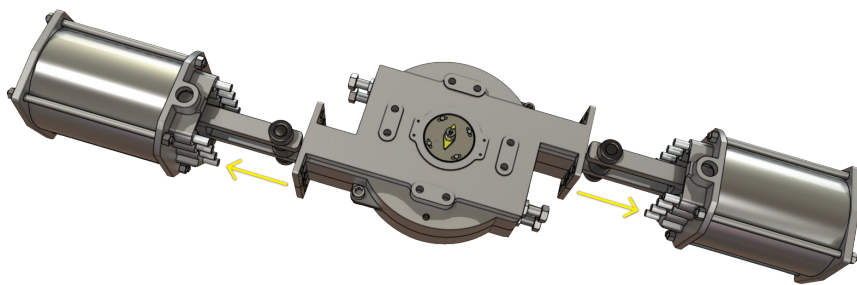

6. Remove any hex nuts and bolts securing the two halves of the body together.

Figure 15

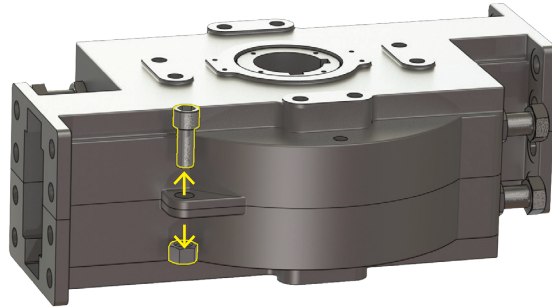

7. Separate the two halves of the body. This may require the use of a pry bar as the joint between the body halves is filled with sealant during assembly.
8. Remove the yoke from the bottom half of the torque module.

Figure 16

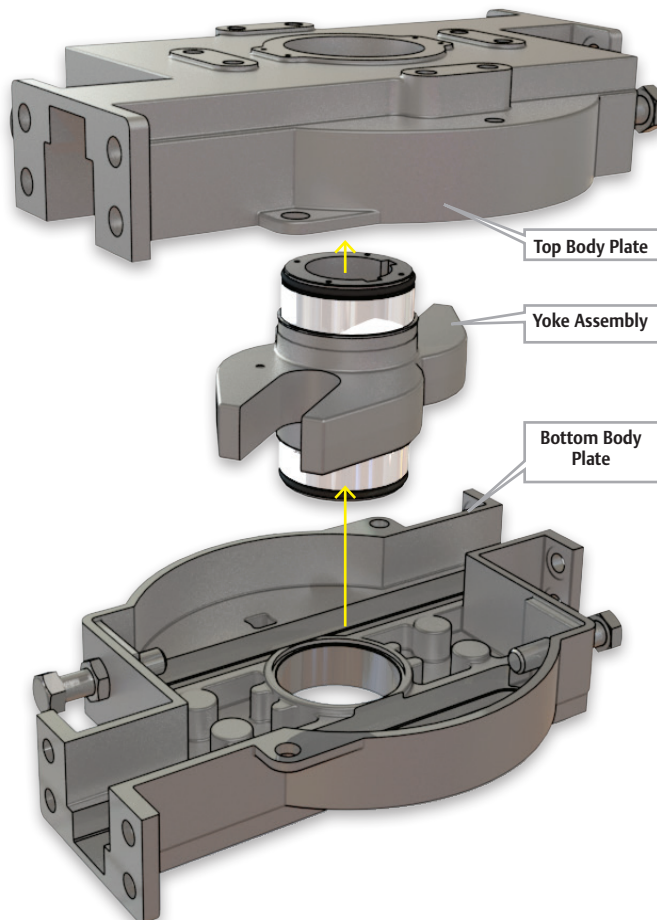

9. Inspect the yoke seals and bushings, and replace all necessary components. Be sure to lubricate the new yoke seals with the correct Bettis approved lubricant prior to their installation.

Figure 17

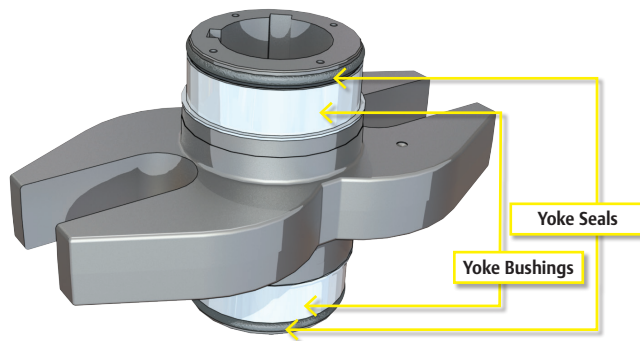

Size 488 and larger the O-ring is in a groove in the body

10. Visually inspect the body slots as well as the pins and rollers on the clevises for wear. If excessive wear is present new slide inserts(if applicable), pins, rollers, or a new actuator may be necessary for further safe, reliable operation.
11. Remove the original sealant from the joining edges of the two separate halves of the body.
12. Position the yoke as shown below. This will allow the pins and rollers of the force modules to slide into their appropriate position between the yoke arms.

Figure 18

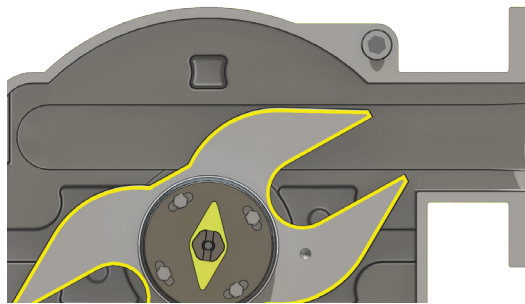

13. Apply a bead of Bettis approved sealant along the joining edges of the bottom half of the body.

Figure 19

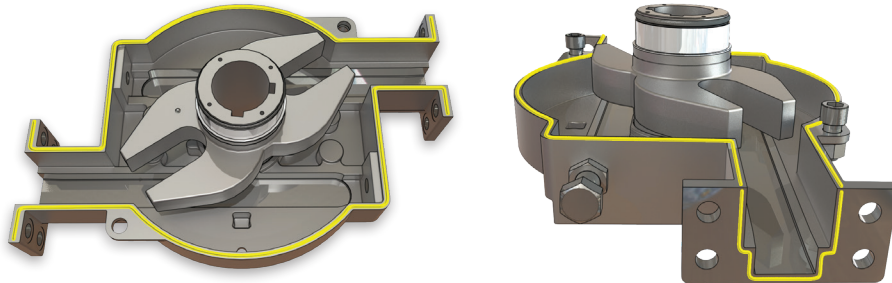

14. Place the top half of the body onto the bottom half and secure the two together with the original bolts and hex nuts removed in step six.
15. Insert both force modules into the torque module simultaneously to ensure that both are joined correctly with the torque module.
16. Coat the threads of the hex nuts removed in step four with medium strength thread locker and secure the force modules to the torque module with the hex nuts. Torque the nuts to the corresponding value in the table below.

Table 5.

Model	Ft-Lbs	Nm
2200, 2250, 2300	120	163
2375, 2488	235	318
2575	400	542

17. Cycle the actuator to ensure all components are working correctly.
18. Reattach the actuator to the valve and reinstate the actuator to service.

4.6 Pins and Rollers Replacement

Figure 20

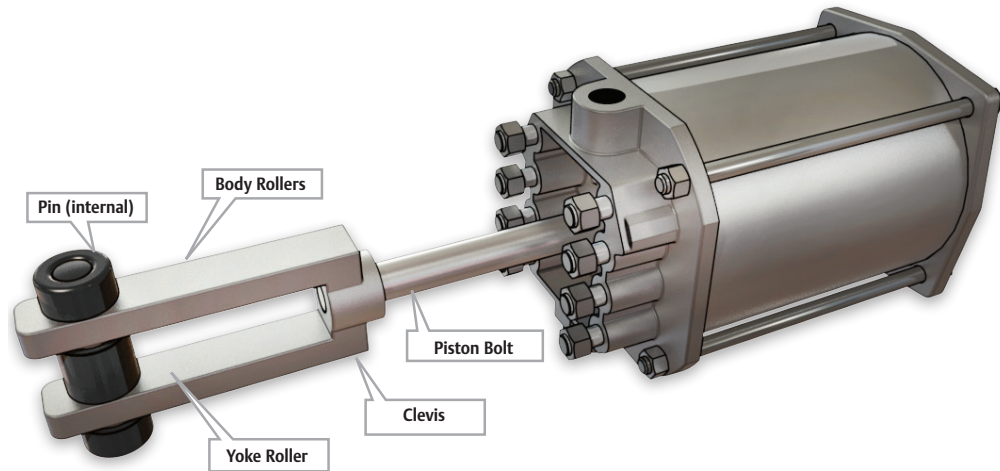

The following steps can be followed to replace the pins and rollers of the force modules.

1. Complete steps 1 to 5 of Section 4.5.
2. Apply pressure to the pressure port on the end cap (P1 or P2) of the force module. This will cause the piston bolt to protrude from the force module and allow the user to inspect it.
3. Inspect the piston bolt, clevis, pin and rollers for wear. This includes any pitting, or cracking. Replace the necessary components. Spare parts may be obtained through your Bettis distributor.
4. Apply heat to break the thread locker on the set screw.
5. To replace pins or rollers remove the set screw on the top of the clevis and push the pin through the eyes of the clevis with a punch. This may require an application of heat as the set screw was installed with high strength thread locker.

Figure 21

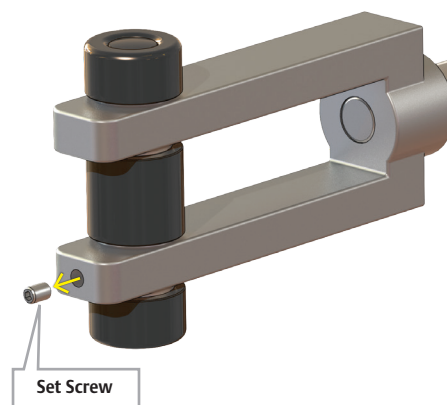

6. Coat the new pins and rollers with the appropriate Bettis approved lubricant and reassemble them. Apply high strength thread locker. Align pin slot with hole in the clevis and install set screw, torque the pin set screw to the corresponding value in the table below.

Table 6.

Model	Ft-Lbs	Nm
2200	35	4
2250	44	5
2300, 2375	106	12
2488, 2575	212	24

Figure 22



7. Repeat steps 2 to 6 of this Section on the second force module.
8. Repeat steps 16 to 18 of Section 4.5.

Appendix A:

A.1 Force Module

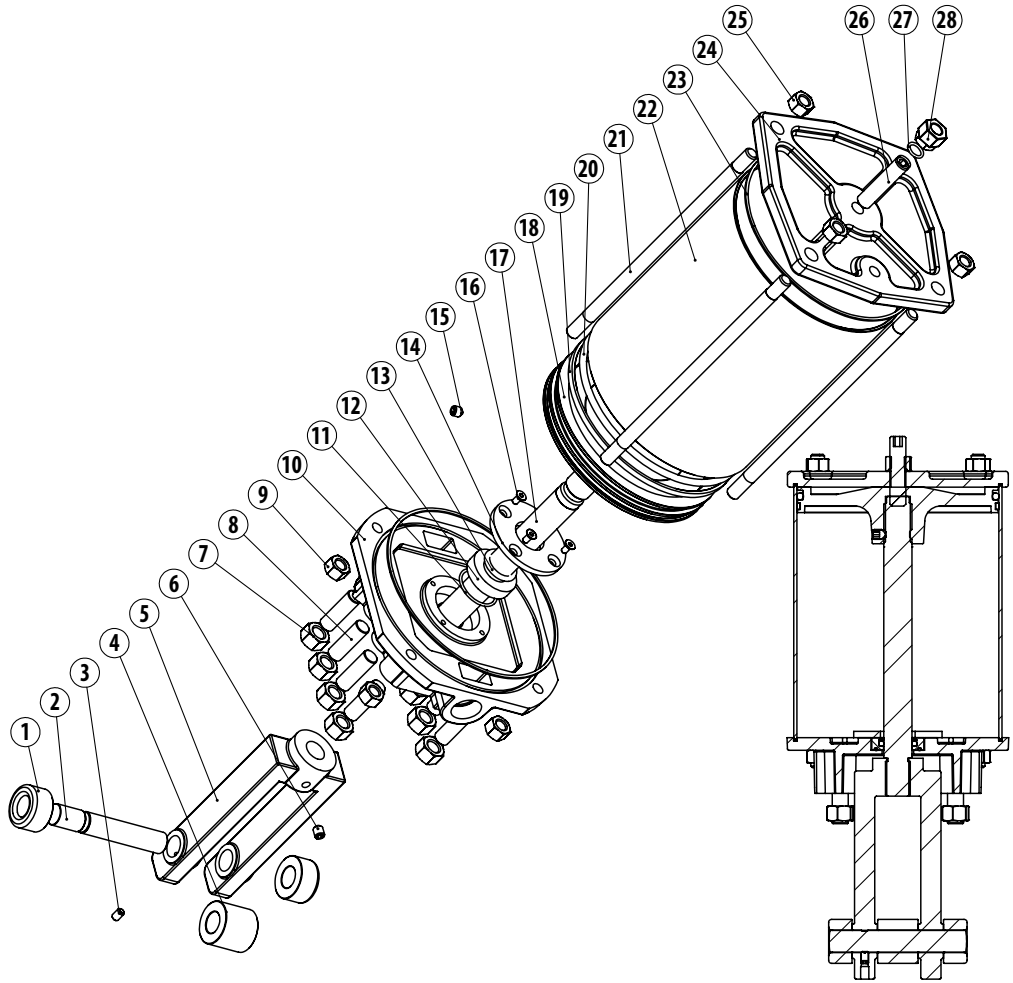

4.6.1 Force Module Part Number

Number	Part
1	Body Roller
2	Pin
3	Pin Set Screw
4	Yoke Roller
5	Clevis
6	Clevis Set Screw
7	Hex Nut, FM Mount
8	Stud
9	Hex Nut, Tie Rod Backup*
10	Base Plate
11	External Seal Carrier O-ring
12	Seal Carrier
13	Internal Seal Carrier O-ring
14	Seal Retainer
15	Piston Set Screw
16	Seal Retainer Bolt
17	Piston Bolt
18	Piston
19	Wiper Ring
20	Piston O-ring
21	Tie Rod
22	Cylinder
23	Cylinder Seal
24	End Cap
25	Tie Rod Nut
26	Travel Stop A
27	Travel Stop O-ring
28	Travel Stop Nut A

*Not present on cylinder sizes 6 inches or less.

A.2 Torque Module

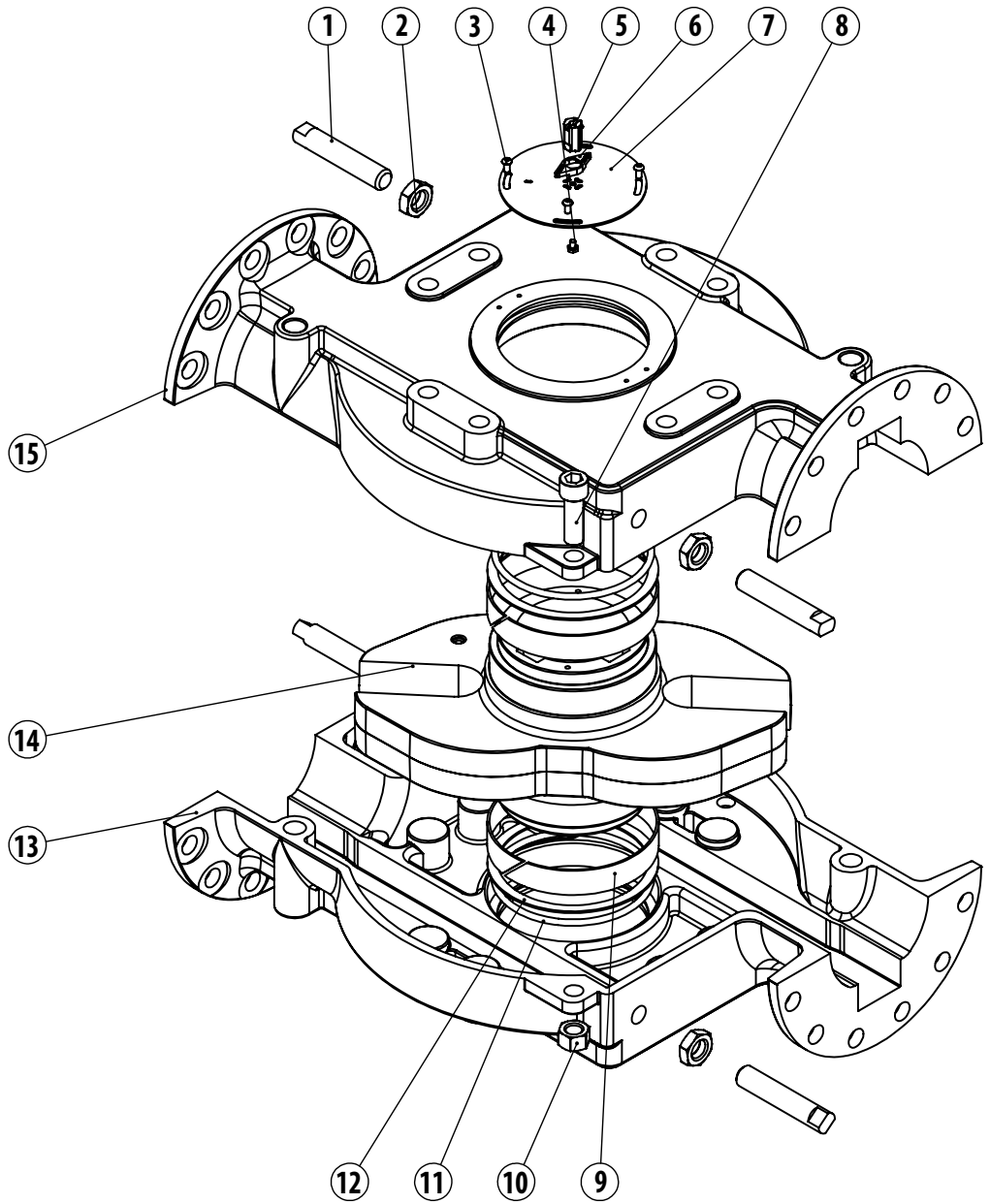

4.6.2 Torque Module Part Number

Number	Part
1	Travel Stop B
2	Travel Stops Nut B
3	Top Hat Mounting Bolt
4	Top Hat Bolt
5	Top Hat
6	Top Hat Indicator
7	Top Hat Base
8	Body Assembly
9	Yoke Bushing
10	Body Assembly Nuts
11	Yoke O-ring
12	Yoke Thrust Washer
13	Body Bottom
14	Yoke
15	Body Top

World Area Configuration Centers (WACC) offer sales support, service, inventory and commissioning to our global customers. Choose the WACC or sales office nearest you:

NORTH & SOUTH AMERICA

19200 Northwest Freeway
Houston TX 77065
USA
T +1 281 477 4100

Av. Hollingsworth
325 Iporanga Sorocaba
SP 18087-105
Brazil
T +55 15 3413 8888

ASIA PACIFIC

No. 9 Gul Road
#01-02 Singapore 629361
T +65 6777 8211

No. 1 Lai Yuan Road
Wuqing Development Area
Tianjin 301700
P. R. China
T +86 22 8212 3300

MIDDLE EAST & AFRICA

P. O. Box 17033
Jebel Ali Free Zone
Dubai
T +971 4 811 8100

P. O. Box 10305
Jubail 31961
Saudi Arabia
T +966 3 340 8650

24 Angus Crescent
Longmeadow Business Estate East
P.O. Box 6908 Greenstone
1616 Modderfontein Extension 5
South Africa
T +27 11 451 3700

EUROPE

Holland Fasor 6
Székesfehérvár 8000
Hungary
T +36 22 53 09 50

Strada Biffi 165
29017 Fiorenzuola d'Arda (PC)
Italy
T +39 0523 944 411

For complete list of sales and manufacturing sites, please visit www.emerson.com/actuationtechnologieslocations or contact us at info.actuationtechnologies@emerson.com

www.emerson.com/bettis

©2018 Emerson. All rights reserved.

The Emerson logo is a trademark and service mark of Emerson Electric Co. Bettis™ is a mark of one of the Emerson family of companies. All other marks are property of their respective owners.

The contents of this publication are presented for information purposes only, and while every effort has been made to ensure their accuracy, they are not to be construed as warranties or guarantees, express or implied, regarding the products or services described herein or their use or applicability. All sales are governed by our terms and conditions, which are available on request. We reserve the right to modify or improve the designs or specifications of our products at any time without notice.

BETTIS™

