

2000LP Multi-Turn Pneumatic Actuators

Low Pressure Air/Gas Power For Gate And Large Bore Quarter-Turn Valves



EIM™

EMERSON™

Designed To Handle Every Low Pressure Valve Control Need In Your System

The EIM 2000LP pneumatic actuator from Emerson is a multi-turn air driven actuator that is perfect for applications using linear, rising stem or rotating stem valves. Developed for operation in any application where reliable electricity is not available, the 2000LP operates valves using 40-100 psi (2.8 – 6.9 bar) air or other suitable gases as its power source.

The robust actuator is based on the proven EIM Series 2000 platform, with more than a half-century of outstanding field performance around the globe. It has the most durable internal components in the industry, assuring long-term reliability.

Widely used throughout all industries since the 1970's, the 2000LP is well suited for any industrial or pipeline application where compact design, simple manual over-ride, travel limits, and torque protection are desired.

The 2000LP can handle virtually any local or remote control system requirement. A variety of standard single or double acting pneumatic and electric remote control configurations are available with optional electric limit switches.

The actuator, as an independent unit, is capable of producing up to 900 lb/ft (1,220 Nm) of torque and 45,000 lb (200.18 kN) of thrust. Torque outputs up to 135,000 lb/ft (183,036 Nm) and thrust outputs up to 900,000 lbs (4,003.6 kN) can be attained through the addition of bevel or worm gearboxes.

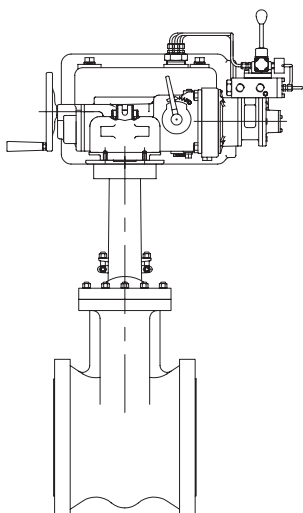

2000LP Is Distinctive

- Adaptable to quarter-turn or multi-turn applications
- Directly mounting on rising stem valves
- Manual override, travel limits, and torque protection are standard
- Highly visible position indication dial available when using electric control pack
- Usable with bevel or worm gears
- Local/remote controls
- Padlockable clutch handle in either hand or motor position
- Handwheel operation in power loss or emergency operation
- Corrosion resistant valving
- MSS or ISO mounting flanges

2000LP Offers Numerous Benefits

- More economical than linear piston actuators
- Provides reliable emergency shutdown service
- Can be equipped for operation with pressurized air, nitrogen or natural gas
- Hundreds of torque/thrust/speed combinations available
- Compact design for space saving installations
- Mechanically locks valve in place when idle
- Eliminates hydraulic manual override

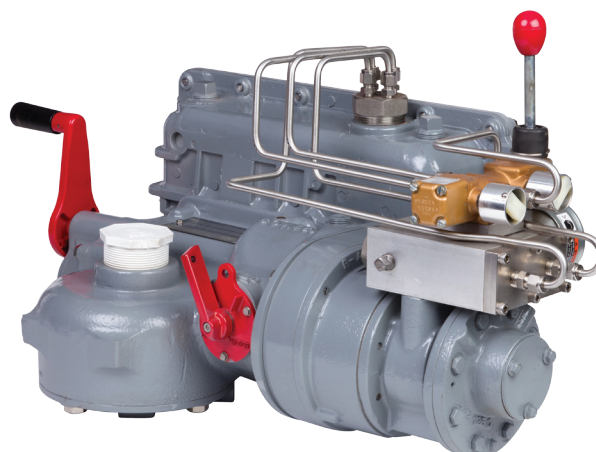

2000LP Features

- Built using the same rugged design of the EIM Series 2000 electric actuator

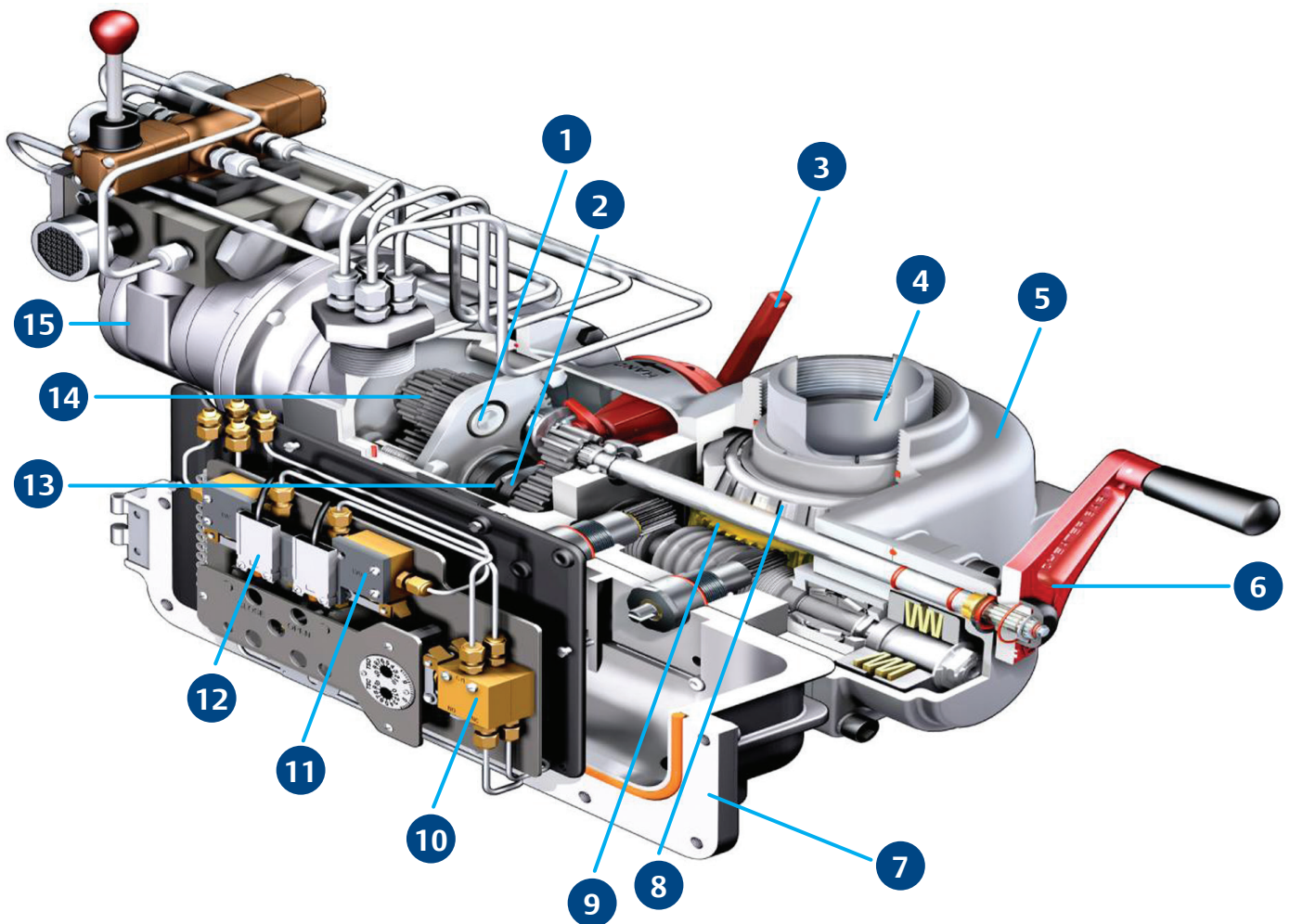

Rugged Features are integral to the 2000LP design

- | | | | |
|---|---|----|---|
| 1 | Bearing supported shafts (no bushings) | 9 | Permanently self-locking worm and wheel |
| 2 | Automatic motor priority | 10 | Torque protection (internal and standard) |
| 3 | Low declutch force | 11 | Travel limits (internal and standard) |
| 4 | Valve stem never disengages from the drive sleeve | 12 | Position indication (optional) |
| 5 | Ductile iron housing | 13 | Low torque side declutching |
| 6 | Low rim-pull (80 lbs/350N maximum) | 14 | Alloy steel motor gear selections allow numerous speed and torque output combinations |
| 7 | Hinged cover, O-ring sealed controls enclosure | 15 | Low consumption pneumatic vane air motor |
| 8 | Tapered top and bottom roller bearings | | |

2000LP Control Details

- 2000LP control power supply range 10 to 100 psi (0.7 to 6.9 bar)
- Motor rating 40 to 100 psi (2.8 to 6.9 bar)
- Local control function utilizing manually-operated selector valve
- Meets ingress protection classification IP66

Control Options

- Optional electrical position indication switches available. Switch certification rating: II 2g Ex d IIc T6; IID Ex tD A21 IP66 T80C
- Optional electric remote operation available. Solenoid certification rating: Class I, Div I, Grp C&D; Class II Div I, Grp E, F, G. ATEX certified solenoids available on request
- Custom control schemes available

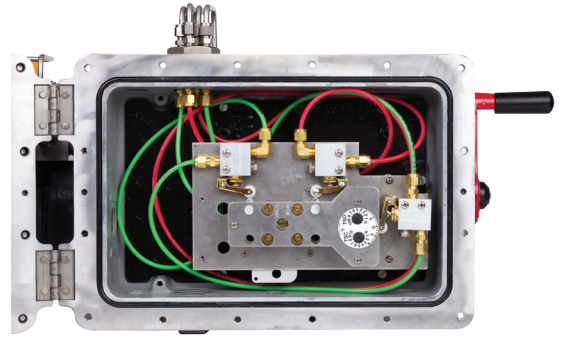

This product is only intended for use in large-scale fixed installations excluded from the scope of Directive 2011/65/EU on the restriction of the use of certain hazardous substances in electrical and electronic equipment (RoHS 2).

World Area Configuration Centers (WACC) offer sales support, service, inventory and commissioning to our global customers. Choose the WACC or sales office nearest you:

NORTH & SOUTH AMERICA

19200 Northwest Freeway
Houston TX 77065
USA
T +1 281 477 4100
F +1 281 477 2809

Av. Hollingsworth
325 Iporanga Sorocaba
SP 18087-105
Brazil
T +55 15 3238 3788
F +55 15 3228 3300

ASIA PACIFIC

No. 9 Gul Road
#01-02 Singapore 629361
T +65 6777 8211
F +65 6268 0028

No. 1 Lai Yuan Road
Wuqing Development Area
Tianjin 301700
P. R. China
T +86 22 8212 3300
F +86 22 8212 3308

MIDDLE EAST & AFRICA

P. O. Box 17033
Dubai
United Arab Emirates
T +971 4 811 8100
F +971 4 886 5465

P. O. Box 10305
Jubail 31961
Saudi Arabia
T +966 3 340 8650
F +966 3 340 8790

24 Angus Crescent
Longmeadow Business Estate East
P.O. Box 6908 Greenstone
1616 Modderfontein Extension 5
South Africa
T +27 11 451 3700
F +27 11 451 3800

EUROPE

Berenyi u. 72- 100
Videoton Industry Park
Building #230
Székesfehérvár 8000
Hungary
T +36 22 53 09 50
F +36 22 54 37 00

For complete list of sales and manufacturing sites, please visit www.emerson.com/actuationtechnologieslocations or contact us at info.actuationtechnologies@emerson.com

©2017 Emerson. All rights reserved.

The Emerson logo is a trademark and service mark of Emerson Electric Co. EIM™ is a mark of the Emerson family of companies. All other marks are property of their respective owners.