

BETTIS™

E-Series Pneumatic and Hydraulic Quarter Turn Valve Operators

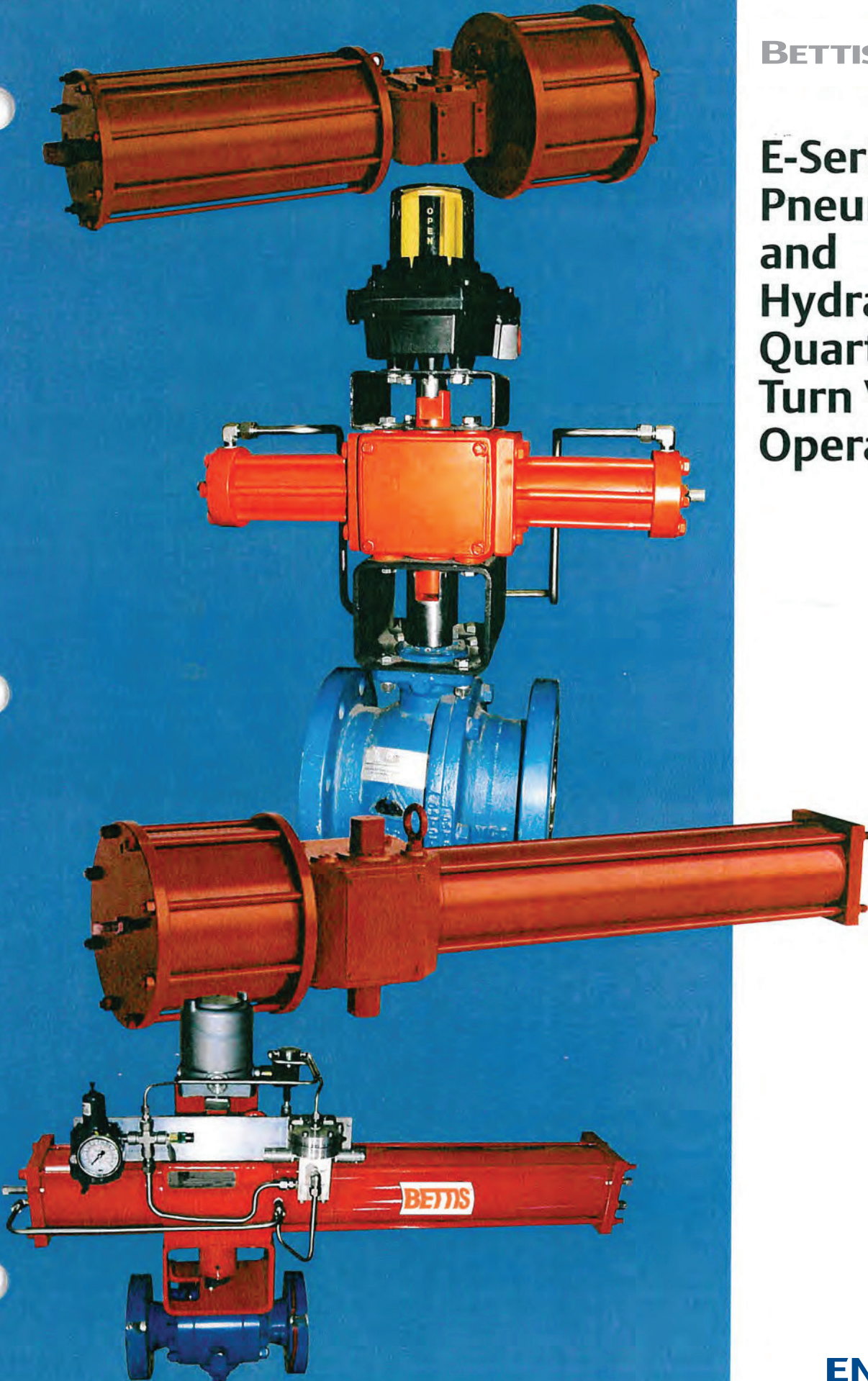

EMERSON™

INTRODUCTION

Bettis Canada offers a comprehensive line of quarter turn pneumatic and hydraulic operators with torque outputs from 500 to 1,500,000 lb. in. By incorporating field proven accessories, and being readily adaptable to meet both standard and specialized requirements, an operator and control system package can be custom tailored for each specific application.

MODEL IDENTIFICATION

Cylinder Size	Series Number	Cylinders	Model Suffixes (Omitted if Not Applicable)			
OO Cylinder Bore Diameter	OO Identifies Series	X Cylinder Arrangement	SR Spring Return Model	OOO Spring Class	Hydraulic	MXX Manual Override Options
Omitted here, because each cylinder has a unique cylinder bore diameter from 3-1/2" to 7"	35	"S" for one or "D" for two cylinders pressurized per stroke.	A spring provides for "failsafe" operation.	Spring Class identifies particular spring.	Hydraulic model	"MJ" – Single jackscrew and handwheel. "MJJ" – Dual jackscrew and handwheel. "MH" – Hydraulic override with handpump.
	50					
60	DSRH models are exceptions. They use one single action hydraulic cylinder opposite the designated spring.					
70	DSRH models are exceptions. They use one single action hydraulic cylinder opposite the designated spring.					
Power cylinder bore sizes from 2" to 24".	3	"S" for single cylinder construction, one side pressurized per stroke: "D" for dual cylinder construction two cylinders pressurized per stroke.	A spring provides "failsafe" operation.	Spring Class identifies particular spring.	Hydraulic model	
	6					
	7					
DSRH models are exceptions: identification is by spring cylinder diameter		DSRH models are exceptions. They use one single action hydraulic cylinder opposite the designated spring.				

BASIC FEATURES

- Design:** Scotch yoke mechanism for high breakaway and reset torque: ideal for quarter turn valves
- Construction:** Modular, with basic drive case/cylinder combinations to most economically suit field requirements
 - Piston type for reliable, positive sealing
 - Double acting or spring return styles
 - Stabilized drive rods where required by sideloads
 - Safe, reliable and field removable spring cartridges
 - Tie rod cylinder construction for simplified maintenance
- Material:** Durable, lightweight cast aluminum drive cases are standard – ideal for low temperature and sour service conditions
 - Ductile iron or cast steel drive cases available
 - Stress relieved cast steel or ductile iron yokes
 - Filament wound fiberglass pneumatic cylinders (steel cylinders optional); steel hydraulic cylinders
 - Nitrite seals are standard; special low temperature or high temperature fluoroelastomer
 - No brass or bronze components
 - Special trims and coatings for corrosive applications
- Mounting:** Easily adaptable to all quarter turn valves
- Controls:** Complete control packages to suit specific applications
 - Local, remote, failsafe or self-contained hydraulic systems using Bettis components in conjunction with field proven accessories
- Temperature:** Low temperature trim is standard: -50°F to +150°F (Buna/Polyslide)
 - Trim:** High temperature trim is optional: -20°F to +225°F (H-T Fluoroelastomer)
 - Extreme low temperature trim is optional: -65°F to +150°F (FSi/Polyslide)
- Special:** Custom design and manufacturing available to meet unique requirements

SERIES 3, 6 AND 7 – DIMENSIONS AND DATA

B. Hydraulic Operators

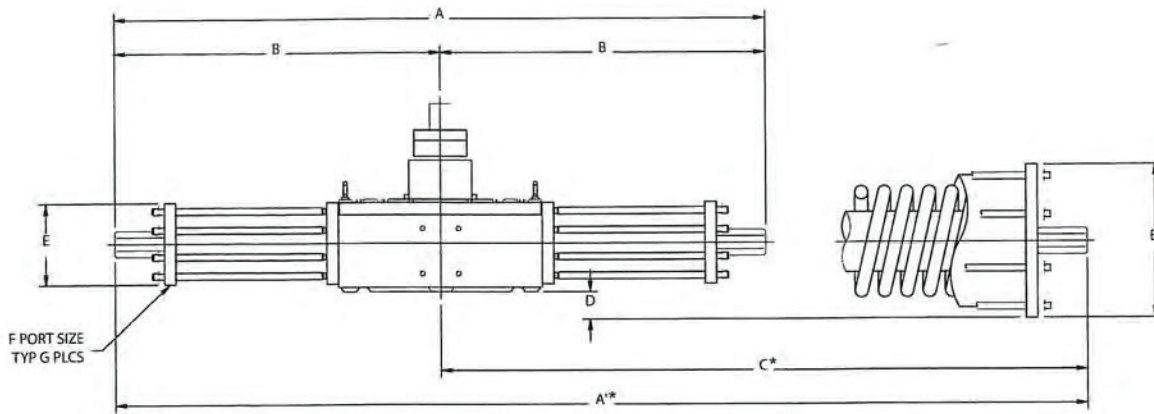

Model	Dimensions (in.)									Weight (lb.)	Actuator Displacement (in. ³)	Nominal Stroke (in.)	Cylinder Bore (in.)
	A	A**	B	C*	D	E	E'	F (NPT)	G				
23 SH	47	-	23-1/2	-	-	2-7/8	-	1/4	2	140	22	7	2
33 DH	51	-	25-1/2	-	-	5-5/8	-	3/8	4	170	77	7	3
43 DH	51	-	25-1/2	-	-	6-5/8	-	3/8	4	210	154	7	4
53 DH	51	-	25-1/2	-	-	8-5/8	-	3/8	4	280	253	7	5
83 DSRH	-	66	24-1/4	41-3/4	2-1/16	5-5/8	10-3/4	3/8	1	300	50	7	3
103 DSRH	-	73-3/4	24-1/4	49-1/2	3-1/16	6-5/8	12-3/4	3/8	1	430	88	7	4
123 DSRH	-	64	24-1/4	39-3/4	4-1/16	8	14-3/4	3/8	1	490	140	7	5
46 DH	72	-	36	-	-	6-5/8	-	3/8	4	390	181	11	4
56 DH	72	-	36	-	-	8	-	3/8	4	450	322	11	5
66 DH	72	-	36	-	-	9-1/4	-	3/8	4	530	495	11	6
166S-SRH	-	92-3/4	36-1/4	56-1/2	3-1/8	8	16-7/8	3/8	1	1,250	216	11	5
186S-SRH	-	101-5/8	36-5/8	65	5-1/8	9-1/4	20-7/8	3/8	1	1,400	311	11	6
57 DH	100	-	50	-	-	8-3/4	-	1/2	4	1,300	374	14	5
67 DH	100	-	50	-	-	9-3/4	-	1/2	4	1,450	616	14	6
77 DH	100	-	50	-	-	11-1/4	-	1/2	4	1,610	902	14	7
87 DH	100	-	50	-	-	12-5/8	-	1/2	4	1,880	1,230	14	8
97 DH	100	-	50	-	-	13-1/4	-	1/2	4	2,060	1,605	14	9
107 DH	100	-	50	-	-	14-1/4	-	1/2	4	2,320	2,023	14	10
107 DH-8B	112	-	50	62	-	14-1/4	-	1/2	4	2,500	2,230	14	10
147 DSRH	-	133-1/4	48-7/8	84-3/8	1-3/4	9-1/4	16-3/4	1/2	1	2,300	396	14	6
167 DSRH	Consult Factory for Sizing										539	14	7
187 DSRH	Consult Factory for Sizing										703	14	8

*Note: Dimensions A' and C refer to spring return models.

TORQUES

A. Double Acting Operators

Pneumatic

Model	Max Operating Pressure (PSIG)	End Position Output Torque at Operating Pressure of *					
		60 PSIG	80 PSIG	100 PSIG	120 PSIG	140 PSIG	150 PSIG
35 S	150	1,270	1,690	2,110	2,530	2,950	3,165
35 D	150	2,460	3,280	4,100	4,920	5,600	5,600
50 S	150	4,240	5,660	7,070	8,480	9,900	10,600
50 D	150	8,280	11,000	13,800	16,600	19,300	20,700
60 D	150	14,600	19,400	24,300	29,200	34,000	36,450
70 D	150	24,400	32,500	40,600	48,700	56,800	60,900
103 S	150	26,400	35,200	44,000	52,800	61,600	66,000
123 S	150	38,000	50,600	63,300	76,000	88,600	94,950
143 S	150	51,700	69,000	86,200	103,440	120,680	129,300
163 S	150	67,800	90,400	113,000	135,600	150,000	150,000
106 S	150	41,500	55,300	69,100	82,900	96,800	103,500
126 S	150	59,700	79,600	99,500	119,000	139,000	149,000
146 S	150	81,300	108,000	135,000	163,000	190,000	202,500
146 D	150	159,000	212,000	265,000	318,000	371,000	397,000
166 S	150	106,000	142,000	177,000	212,000	248,000	265,500
166 D	110	209,000	278,000	348,000	-	-	-
186 S	150	134,000	179,000	224,000	269,000	314,000	336,000
186 D	90	265,000	353,000	-	-	-	-
147 D	140	199,000	265,000	331,000	397,000	463,000	-
167 S	140	135,000	180,000	225,000	270,000	315,000	-
167 D	140	262,000	349,000	436,000	523,000	610,000	-
187 D	120	334,000	445,000	556,000	667,000	-	-
207 D	120	414,000	552,000	690,000	828,000	-	-
247 D	120	599,400	799,200	999,000	1,200,000	-	-

*Note: All torques in lb. in. Minimum torque is 1/2 End Torque.

Hydraulic

Model	Max Operating Pressure (PSIG)	End Position Output Torque at Operating Pressure of *					
		500 PSIG	750 PSIG	1000 PSIG	1250 PSIG	1500 PSIG	2000 PSIG
35 SH	2,000	2,250	3,420	4,560	5,600	5,600	5,600
50 SH	2,000	8,850	13,300	17,700	22,000	22,000	22,000
60 SH	2,000	15,500	23,200	31,000	38,000	38,000	38,000
70 SH	2,000	26,000	39,000	52,000	65,000	65,000	65,000
23 SH	1,500	9,350	13,500	18,700	23,375	28,050	-
33 DH	1,500	32,500	48,700	65,000	81,250	97,500	-
43 DH	1,500	65,500	97,500	131,000	150,000	150,000	-
53 DH	1,440	107,000	112,500	150,000	150,000	-	-
46 DH	1,500	84,500	115,000	169,000	211,250	253,500	-
56 DH	1,500	150,500	205,000	301,000	376,250	400,000	-
66 DH	1,500	231,500	315,000	400,000	400,000	400,000	-
57 DH	1,500	159,000	238,000	318,000	397,500	477,000	-
67 DH	1,500	261,500	392,000	523,000	653,750	784,500	-
77 DH	1,500	383,000	574,500	766,000	957,500	1,149,000	-
87 DH	1,500	522,500	780,000	1,045,000	1,306,250	1,500,000	-
97 DH	1,500	682,000	1,020,000	1,364,000	1,500,000	1,500,000	-
107 DH	1,440	860,000	1,290,000	1,500,000	1,500,000	-	-
107 DH-8B	1,440	1,160,000	1,500,000	1,500,000	1,500,000	-	-

*Note: All torques in lb. in. Minimum torque is 1/2 End Torque.

TORQUES

B. Spring Return Operators

Pneumatic

Model	Min. Operating Pressure (PSIG)	Max. Operating Pressure (PSIG)	Calculated Spring Unloading Torque (lb. in.)			Calculated Air Loading Torque at Min. Oper. Pres (lb. in.)		
			Starting	Mid-Stroke	Ending	Starting	Mid-Stroke	Ending
35S-SR60	60	150	880	350	516	754	285	386
35S-SR80	80	150	1,200	476	702	991	370	491
35D-SR40	40	150	1,040	397	544	1,100	423	596
35D-SR60	60	150	1,800	686	940	1,520	544	657
35D-SR80	80	150	2,320	924	1,370	1,910	717	960
35D-SR100	100	150	2,730	1,060	1,530	2,570	986	1,370
35D-SR120	120	150	3,610	1,440	2,140	2,780	1,020	1,310
50S-SR60	60	150	3,050	1,200	1,770	2,480	916	1,190
50S-SR80	80	150	4,090	1,620	2,370	3,290	1,210	1,560
50S-SR100	100	150	5,290	2,060	2,950	4,120	1,470	1,780
50D-SR40	40	150	4,140	1,640	2,420	3,100	1,120	1,370
50D-SR60	60	150	5,630	2,230	3,280	4,990	1,910	2,640
50D-SR80	80	150	8,140	3,220	4,750	6,280	2,290	2,890
50D-SR100	100	150	9,770	3,870	5,700	8,080	3,020	4,010
60D-SR40	40	150	6,730	2,650	3,890	5,830	2,200	2,990
60D-SR60	60	150	11,600	4,850	7,820	6,750	2,440	3,010
60D-SR80	80	150	12,200	4,810	7,050	12,400	4,900	7,230
60D-SR100	100	150	16,300	6,440	9,420	14,900	5,710	7,970
60D-SR120	120	150	19,600	7,750	11,300	17,800	6,830	9,500
70D-SR40	40	150	10,500	4,170	6,170	10,100	3,950	5,740
70D-SR60	60	150	16,600	6,590	9,750	14,600	5,590	7,760
70D-SR80	80	150	23,200	9,200	13,600	18,900	7,040	9,300
70D-SR100	100	150	27,700	10,900	15,800	24,800	9,430	12,900
70D-SR120	120	150	33,400	13,300	19,600	29,100	11,100	15,300
70D3-SR80	80	150	33,400	13,300	19,600	28,700	10,900	14,900
70D3-SR120	120	150	41,800	16,900	25,800	46,700	19,400	30,700
123S-SR60	60	150	20,900	8,150	11,700	26,300	10,800	17,100
123S-SR80	80	150	28,600	11,300	16,400	34,200	14,100	22,000
123S-SR100	100	150	35,600	14,000	20,400	43,000	17,700	27,700
143S-SR60	60	150	34,900	14,200	21,800	29,900	11,700	16,900
143S-SR80	80	150	43,800	17,100	24,600	44,400	17,400	25,100
143S-SR100	100	150	55,200	21,100	29,400	56,900	22,000	31,000
163S-SR60	60	150	43,400	17,000	24,600	42,900	16,800	24,100
163S-SR80	80	150	56,900	22,300	32,200	57,900	22,800	33,200
163S-SR100	100	150	78,700	30,700	44,100	68,500	25,600	33,900
146S-SR80	80	150	66,600	25,800	36,800	71,600	28,300	41,800
146S-SR100	100	150	94,800	37,400	54,800	80,600	30,300	40,700
166S-SR60	60	150	76,900	29,600	41,500	64,700	23,500	29,200
166S-SR80	80	150	94,800	37,400	54,800	86,700	33,400	46,800
166S-SR100	100	150	111,000	44,700	67,400	110,000	43,800	65,600
186S-SR80	80	150	134,000	52,000	74,200	105,000	37,600	45,500
186S-SR100	100	150	136,000	55,900	87,300	137,000	56,100	87,800
207S-SR60	60	120	123,000	49,500	74,700	136,000	56,000	88,000
207S-SR80	80	120	179,000	71,500	107,000	174,000	69,200	103,000
207S-SR100	100	120	214,000	84,100	122,000	230,000	91,800	137,000
227S-SR80	80	120	214,000	84,000	122,000	219,000	86,000	126,000
227S-SR100	100	120	284,000	111,000	161,000	264,000	102,000	142,000
267S-SR80	80	120	321,000	118,000	153,000	323,000	119,000	155,000
287S-SR60	60	120	273,000	104,000	144,000	270,000	103,000	141,000

Hydraulic

Model						Calculated Hyd. Loading Torque at Min. Oper. Pres (lb. in.)		
35 DSRM-100	200	275	2,730	1,060	1,530	2,710	1,050	1,500
35D-SRH100	950	2,000 **	2,480	960	1,390	2,810	1,100	1,600
50 DSRH-100	800	2,000 **	9,770	3,870	5,700	8,440	3,200	4,370
60 DSRH-100	1,000	2,000 **	16,300	6,440	9,420	12,200	4,630	5,280
70 DSRH-100	800	2,000 **	27,700	10,900	15,800	25,800	9,910	13,800
70D-SRH120	960	2,000 **	33,400	13,300	19,600	30,200	11,600	16,200
83 DSRH-100	1,500	1,500	35,600	14,000	20,400	50,000	21,200	34,800
103 DSRH-100	1,250	1,500	55,200	21,100	29,400	58,600	22,800	32,700
123 DSRH-100	1,150	1,500	78,700	30,700	44,100	82,300	32,500	47,800
146S-SRH100	900	1,500	94,800	37,400	54,800	101,000	40,400	60,700
166S-SRH100	1,050	1,500	111,000	44,700	67,400	114,000	46,000	70,100
186S-SRH100	900	1,500	136,000	55,900	87,300	137,000	56,100	87,800
207S-SRH100	1,100	1,500	214,000	84,100	122,000	226,000	90,100	134,000
227S-SRH100	1050	1,500	284,000	111,000	161,000	291,000	115,000	169,000

* Note: Calculated torques based on efficiency of 80%, as applied to spring force and piston force.

** Higher pressures may be available – consult factory.

SERIES 3, 6 AND 7 – DIMENSIONS AND DATA

A. Pneumatic Operators

'S' Type Operator

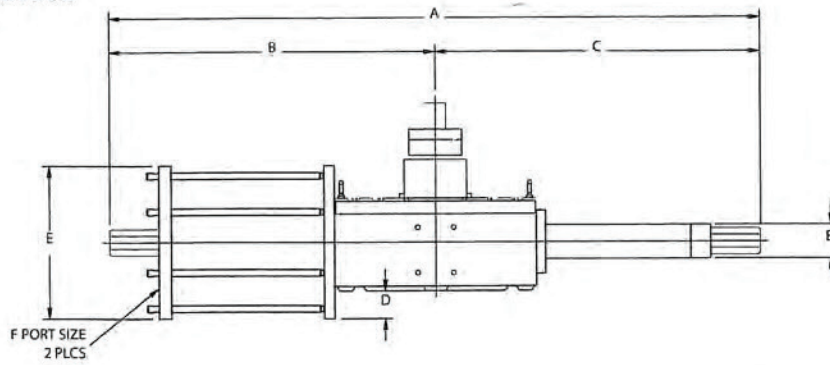

'D'/'SSR' Type Operator

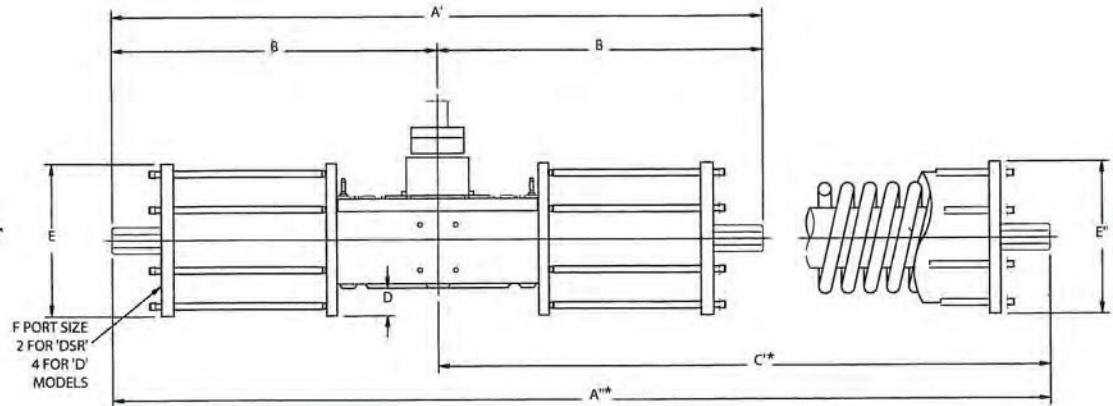

Model	Dimensions (in.)											Weight (lb.)	Actuator Displacement (in. ³)	Nominal Stroke (in.)	Cylinder Bore (in.)
	A	A'	A''	B	C	C'	D	E	E'	E''	F (NPT)				
123S-SR	-	-	66-1/4	24-1/2	-	41-3/4	1-7/16	10-3/4	-	14-3/4	3/8	340	682	7	12
103 S	48	-	-	24-1/2	23-1/2	-	2-7/16	12-3/4	2-3/4	-	3/8	240	553	7	10
143S-SR	-	-	74	24-1/2	-	49-1/2	2-7/16	12-3/4	-	17	3/8	500	1,080	7	14
123 S	48	-	-	24-1/2	23-1/2	-	3-7/16	14-3/4	2-3/4	-	3/8	270	795	7	12
163S-SR	-	-	64-1/4	24-1/2	-	39-3/4	3-7/16	14-3/4	-	18-3/4	3/8	550	1,560	7	16
143 S	48	-	-	24-1/2	23-1/2	-	4-9/16	17	2-3/4	-	1/2	370	1,070	7	14
163 S	48	-	-	24-1/2	23-1/2	-	5-9/16	19	2-3/4	-	1/2	420	1,400	7	16
106 S	73-3/8	-	-	36-1/8	36-1/4	-	1-1/8	12-7/8	6-1/2	-	3/8	750	864	11	10
126 S	73-3/8	-	-	36-1/8	36-1/4	-	2-1/8	14-7/8	6-1/2	-	3/8	800	1,244	11	12
146S-SR	-	-	92-7/8	36-3/8	-	56-1/2	3-1/8	16-7/8	-	16-7/8	1/2	1,350	1,693	11	14
146 S	72-5/8	-	-	36-3/8	36-1/4	-	3-1/8	16-7/8	6-1/2	-	1/2	900	1,693	11	14
146 D	-	72-3/4	-	36-3/8	-	-	3-1/8	16-7/8	-	-	1/2	1,000	3,309	11	14
166S-SR	-	-	92-5/8	36-1/8	-	56-1/2	4-1/8	18-7/8	-	16-7/8	1/2	1,500	2,212	11	16
166 S	73-3/8	-	-	36-1/8	36-1/4	-	4-1/8	18-7/8	6-1/2	-	1/2	1,000	2,212	11	16
166 D	-	72-1/4	-	36-1/8	-	-	4-1/8	18-7/8	-	-	1/2	1,200	4,346	11	16
186S-SR	-	-	101-1/4	36-1/4	-	65	5-1/8	20-7/8	-	20-7/8	1/2	1,650	2,799	11	18
186 S	72-1/2	-	-	36-1/4	36-1/4	-	5-1/8	20-7/8	6-1/2	-	1/2	1,300	2,799	11	18
186 D	-	72-1/2	-	36-1/4	-	-	5-1/8	20-7/8	-	-	1/2	1,400	5,521	11	18
147 D	-	97-1/4	-	48-5/8	-	-	1-3/4	16-3/4	-	-	1/2	1,600	4,130	14	14
207S-SR	-	-	132-1/4	48-5/8	-	83-5/8	1-3/4	16-3/4	-	24	1/2	2,380	4,130	14	20
167 S	94	-	-	48-5/8	45-3/8	-	2-3/4	18-3/4	5-1/4	-	1/2	1,380	2,820	14	14
167 D	-	97-1/4	-	48-5/8	-	-	2-3/4	18-3/4	-	-	1/2	1,730	5,450	14	16
227S-SR	-	-	135-1/4	48-5/8	-	86-5/8	2-3/4	18-3/4	-	25	1/2	2,740	5,450	14	22
187 D	-	97-1/4	-	48-5/8	-	-	3-3/4	20-3/4	-	-	1/2	1,880	6,950	14	18
267S-SR	-	-	135-1/4	48-5/8	-	86-5/8	3-3/4	20-3/4	-	30	1/2	3,170	6,950	14	26
207 D	-	97-1/4	-	48-5/8	-	-	4-3/4	22-3/4	-	-	-	4,000	8,620	14	20
247 D	Consult Factory for Sizing														

*Note: Dimensions A' and C refer to spring return models. Dimensions E'' refers to SSR models.

SERIES 35 – 70 – DIMENSIONS AND DATA

A. Pneumatic Operators

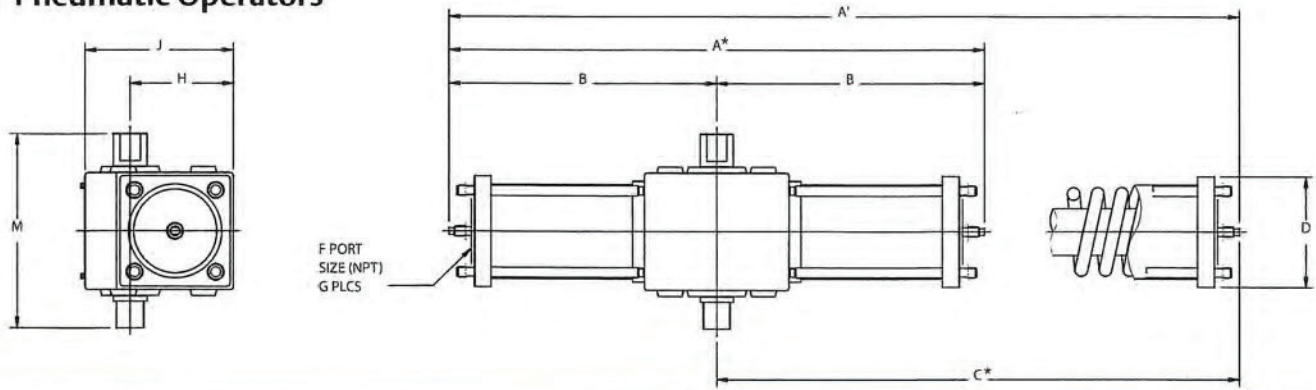

Model	Dimensions (in.)										Weight (lb.)	Actuator Displacement (in. ³)	Nominal Stroke (in.)	Cylinder Bore (in.)
	A	A*	B	C*	D	F	G	H	J	M				
35 S	20-1/4	-	10-1/8	-	4-1/4	1/4	2	4-1/4	6	7-3/8	20	33	2-3/4	3-1/2
35 SSR	-	30-3/4	10-1/8	20-5/8	4-1/4	1/4	1	4-1/4	6	7-3/8	30	33	2-3/4	3-1/2
35 D	19	-	9-1/2	-	4-1/4	1/4	2	4-1/4	6	7-3/8	20	51	2-3/4	3-1/2
35 DSR	-	30-7/8	9-1/2	21-3/8	4-1/4	1/4	2	4-1/4	6	7-3/8	35	51	2-3/4	3-1/2
50 S	28	-	14	-	6	1/4	2	5-3/8	7-1/2	10-5/8	50	88	4-1/2	5
50 SSR	-	39-1/2	14	25-1/2	6	1/4	1	5-3/8	7-1/2	10-5/8	80	88	4-1/2	5
50 D	30	-	13-3/4	-	6	1/4	2	5-3/8	7-1/2	10-5/8	55	173	4-1/2	5
50 DSR	-	47	13-3/4	32-1/2	6	1/4	2	5-3/8	7-1/2	10-5/8	90	173	4-1/2	5
60 D	33-1/2	-	16-3/4	-	7	1/4	2	6-1/2	9-3/8	12-9/16	95	304	5-1/2	6
60 DSR	-	52-3/4	16-3/4	36	7	1/4	2	6-1/2	9-3/8	12-9/16	150	304	5-1/2	6
70 D	41	-	20-1/2	-	8-1/4	1/4	2	7-3/4	11	14-1/2	140	508	6-3/4	7
70 DSR	-	75-3/4	31	44-3/4	8-1/4	1/4	2	7-3/4	11	14-1/2	270	508	6-3/4	7

*Note: Dimensions A' and C refer to spring return models.

B. Hydraulic Operators

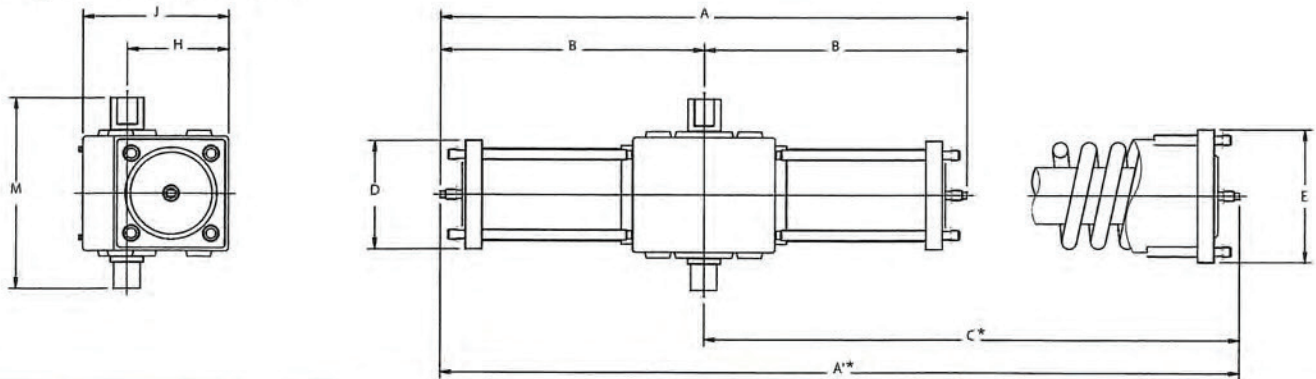

Model	Dimensions (in.)										Weight (lb.)	Actuator Displacement (in. ³)	Nominal Stroke (in.)	Cylinder Bore (in.)	
	A	A*	B	C*	D	E	F	G	H	J					M
35 SH	21	-	10-1/2	-	3-1/4	-	1/4	2	4-1/4	6	7-3/8	25	5.7	2-3/4	1-5/8
35 DSRH	-	31-3/4	10-3/8	21-3/8	3-1/4	4-1/4	1/4	1	4-1/4	6	7-3/8	40	5.7	2-3/4	1-5/8
35 DSRM	-	31-3/4	10-3/8	21-3/8	4-1/4	4-1/4	1/4	1	4-1/4	6	7-3/8	35	33	2-3/4	3-1/2
50 SH	30	-	15	-	5	-	1/4	2	5-3/8	7-1/2	10-5/8	70	22.1	4-1/2	2-1/2
50 DSRH	-	48-1/2	16	32-1/2	5	6	1/4	1	5-3/8	7-1/2	10-5/8	90	22.1	4-1/2	2-1/2
60 SH	34	-	17	-	5-1/2	-	1/4	2	6-1/2	9-3/8	12-9/16	90	38.9	5-1/2	3
60 DSRH	-	54	18	36	5-1/2	7	1/4	1	6-1/2	9-3/8	12-9/16	150	38.9	5-1/2	3
70 SH	40	-	20	-	5-5/8	-	1/4	2	7-3/4	11	14-1/2	140	64.9	6-3/4	3-1/2
70 DSRH	-	65-3/4	21	44-3/4	5-5/8	8-1/4	1/4	1	7-3/4	11	14-1/2	260	64.9	6-3/4	3-1/2

*Note: Dimensions A' and C refer to spring return models.

MOUNTING AND DRIVECASE DIMENSIONS

A. Series 35 – 70

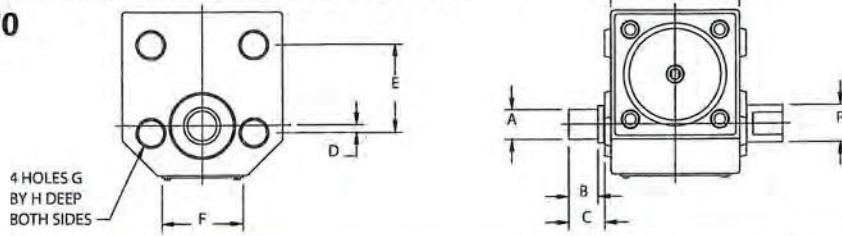

Series	Dimensions (in.)									
	A	B	C	D	E	F	G	H	L	P
35	7/8	1	1-3/8	7/8	4-1/4	3	3/8-16NC	1-1/4	4-5/8	1-1/4
50	1-1/2	1-1/4	2	1/2	4	5	1/2-13NC	1-1/2	4-5/8	2
60	1-3/4	1-3/4	2-1/4	1/2	5-3/8	5-3/4	5/8-11NC	1	8-1/16	2-1/4
70	2	2	2-1/2	1/2	6	7	3/4-10NC	1-1/4	9-1/2	2-1/2

B. Series 3, 6 and 7

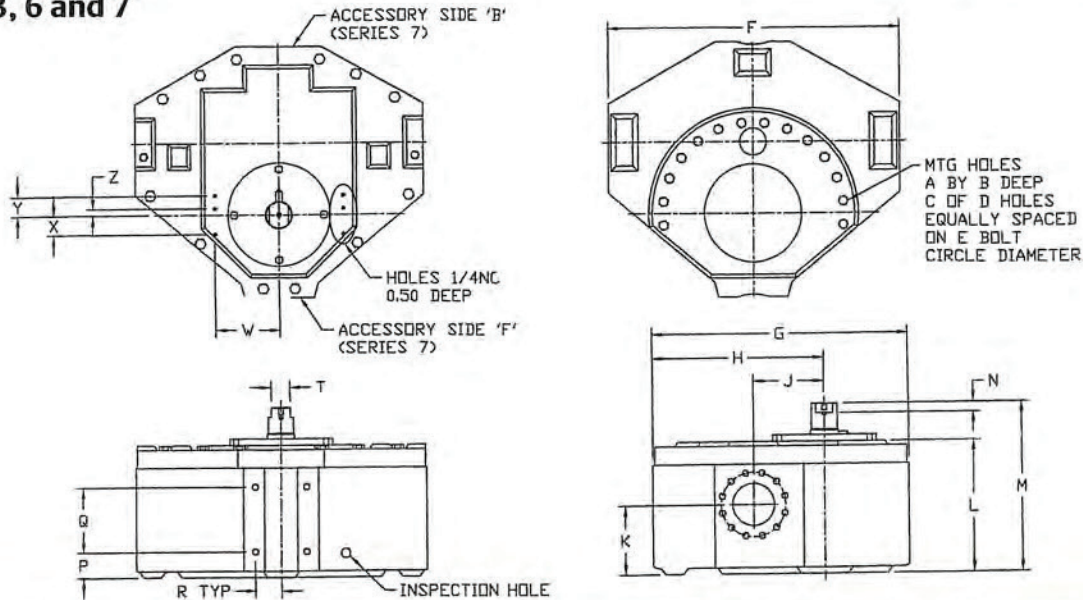

Series	Dimensions (in.)																				
	A	B	C	D	E	F	G	H	J	K	L	M	N	P (F,B)	Q (F,B)	R (F,B)	T	W	X	Y	Z
3	5/8-11NC	1	8	16	9	14.5	12.63	8.5	3.5	3.94	8	11	0.75	1.38, 1.38	4, 4	2, 2	1.5	3.63	N/A	0.38	N/A
6	3/4-10NC	THRU	14	24	14	22.5	19.75	13.75	5.5	5.38	10.25	13.25	0.75	2, 2	5, 5	2, 2	1.5	4.19	1.5	1.5	0.5
7	1-8NC	1.5	14	24	19	31.75	26.25	18.25	7	6.63	13.75	16.75	0.75	3, 3.5	6.5, 6	3.25, 2	1.5	6.88	1.5	1.5	N/A

ISO 9001



Cert. Num. 93-13



Accredited by the Dutch Council for certification

19200 Northwest Freeway
Houston TX 77065
USA
T +1 281 477 4100
F +1 281 477 2809

Av. Hollingsworth
325, Iporanga
Sorocaba
SP 18087-105
Brazil
T +55 15 3238 3788
F +55 15 3228 3300

©2018 Emerson. All rights reserved.

The Emerson logo is a trademark and service mark of Emerson Electric Co. Bettis™ is a mark of one of the Emerson family of companies. All other marks are property of their respective owners.

BETTIS™

Bettis Bulletin #90.00 Rev: 01-17 2M/06-18

www.emerson.com/bettis

EMERSON™