

## SEE-LEVEL

### Illuminator for Transparent Level Gages

For Class 1, Division 1, Group B, C, & D Hazardous Locations

See the difference with the **SEE-LEVEL** Illuminator

- **Brilliant Green LED Backlighting**
  - Green distinguishes liquid from surroundings
  - Up to 4 size 9 gage sections
- **Innovative Mounting Solution**
  - No-bolt cover removal
  - No flimsy, complicated brackets
  - Installs in minutes on any brand gage
  - Fits either side of transparent gages
- **Saves Money**
  - Electricity savings over incandescent bulbs
  - Eliminates time consuming bulb changes
  - Lasts 200 times longer than incandescent bulbs
  - Increases productivity
- **Operates in Any Environment**
  - NEMA 4X & 8 power supply enclosure
  - Watertight, weatherproof and corrosion resistant
  - Conformal coated LED lighting
- **Durable**
  - Positive mounting, no springs or clamps
  - Survives impact
  - Crush tested
  - No exposed wiring
  - Rugged by design

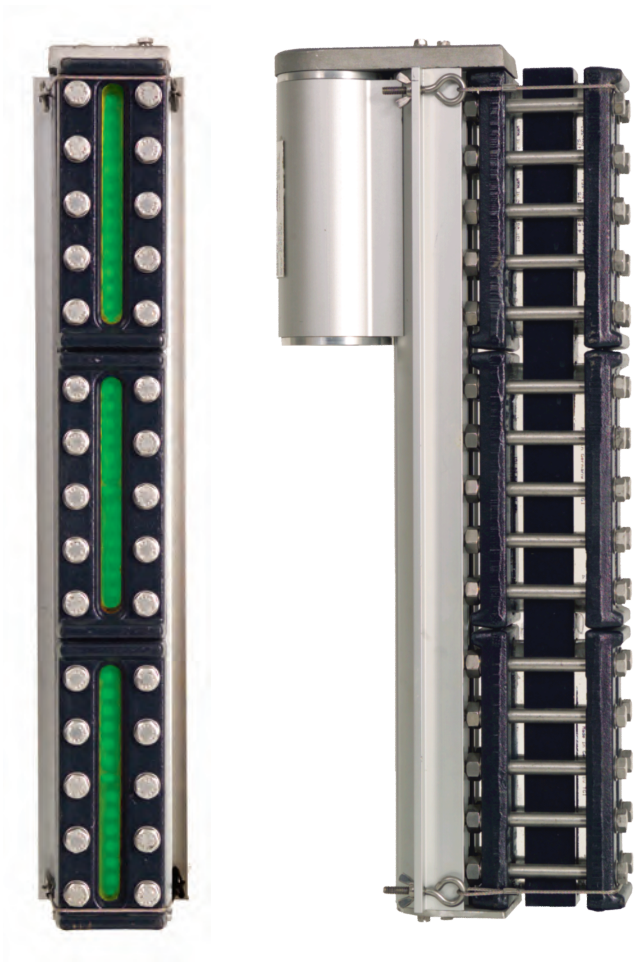

#### Technical Specifications

Power Supply .....	115/230 VAC @ 50/60 HZ	LED Estimated Life .....	100,000 hours
Power Consumption .....	<150 mA @ 115 VAC	Certification .....	UL1203, UL913, CSA 22.2
Supply Connection .....	3/4 NPT		CL I, DIV 1, Groups B, C, & D
Wire Size .....	14 AWG (ground)		NEMA 4X & 8
Ambient Temperature .	-40 °F (-40°C) to 150 °F (65°C)	**For Steam Services Refer to See Level-Amber Illuminator Reference Document Number 200-08	

# SEE-LEVEL

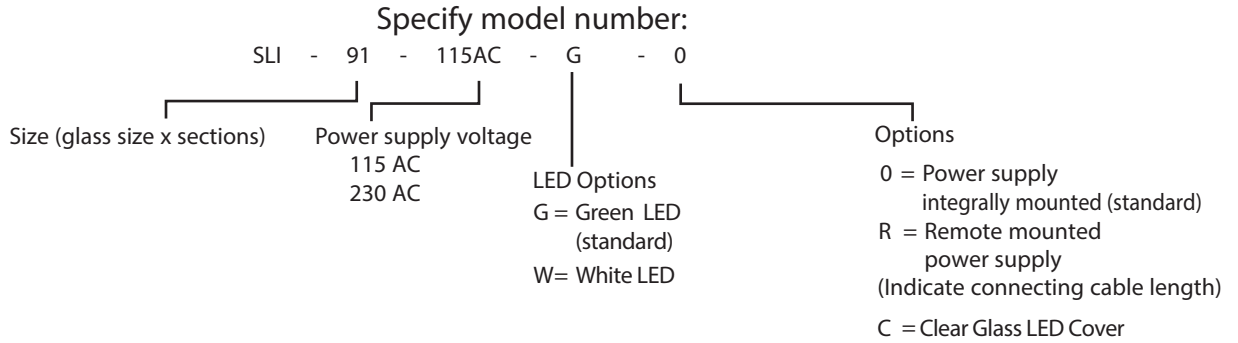

MODEL NUMBER	OVERALL LENGTH "A"	
	INCHES	MILLIMETERS
SLI-51	9.5	241
SLI-61	10.75	273
SLI-71	11.875	302
SLI-81	13.5	343
SLI-91	14.25	362
SLI-32	14.625	371
SLI-42	16.625	422
SLI-52	18.875	479
SLI-62	21.375	543
SLI-72	23.625	600
SLI-82	26.875	683
SLI-92	28.375	721
SLI-63	32	813
SLI-73	35.375	899
SLI-83	40.25	1022
SLI-93	42.5	1080
SLI-74	47.125	1197
SLI-84	53.625	1362
SLI-94	56.625	1438

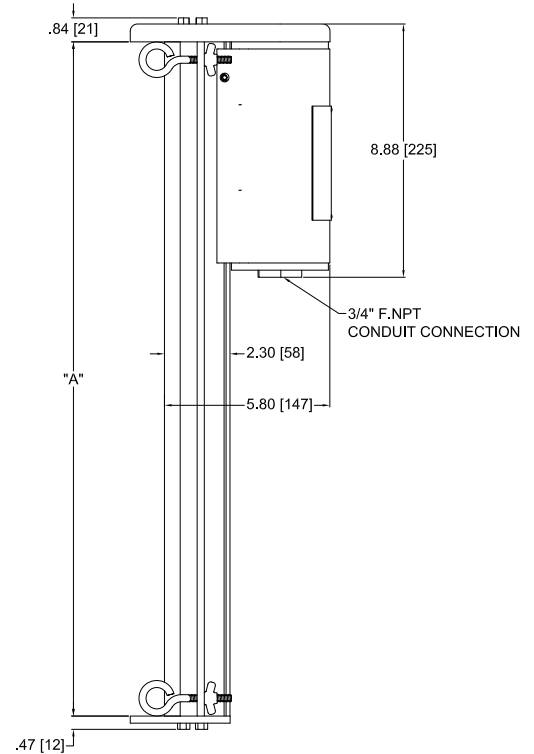
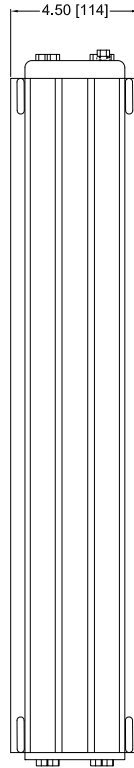

"inches (mm)"

Quest-Tec Solutions purchased the Daniel Level Gage and Valve product line from Emerson Process in 2001



ISO 9001 : 2000

Quest -Tec Solutions

13960 S. Wayside, Houston, TX 77048 U.S.A.

Toll Free Tel: 866.240.9960 • T el: 281.240.0440 • F ax: 281.240.2440

www.QTSLevel.com • sales@QTSLevel.com

Represented by: