

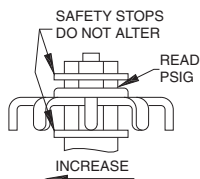

## Series 1000E Diaphragm Operated Pressure Switches

### Installation and Operating Instructions

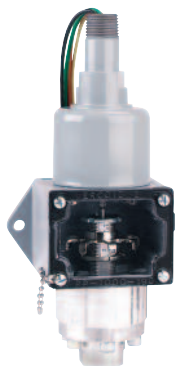

Series 1000E explosion-proof also available in 1000EH explosion-proof, hermetically sealed switch assembly.

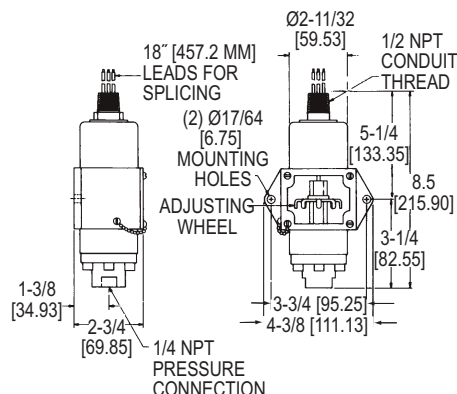

This control is operated by a negative rate Bellville spring-augmented diaphragm.

#### Location and Mounting

Select a location recommended by the equipment manufacturer. Use the two (2) lugs on the case to mount the control on a panel or smooth wall surface, or mount directly by the pressure connection.

The control is not position sensitive and may be mounted in any position. However, vertical is preferred when there is a possibility of sludge accumulation or condensed water freezing in the pressure chamber.

#### Pressure Connection

The pressure connection is a standard female 1/4" NPT taper pipe thread. Pipe thread sealant tape or pipe thread sealant should be used to assure a pressure-tight joint. When used on steam, a pigtail siphon and Type 3 (FEP) diaphragm should be used.

#### Wiring

Wire in accordance with local electrical codes or equipment manufacturer's instructions. Use a short piece of BX between rigid conduit and control so that control will not be subject to the stress of conduit expansion and contraction. Electrical ratings are shown on the label inside the adjusting wheel chamber.

#### DO NOT OVERLOAD

#### Setting Operating Point

Remove the transparent cover over the adjusting wheel. Move the wheel by hand to the desired pressure on the vertical scale. If the adjusting wheel is difficult to move, a small screwdriver inserted in the adjusting wheel arms will provide extra leverage. Safety stops are provided at the top and bottom of the scale to prevent setting beyond the control's range. DO NOT alter. Dial markings are for the High operating point. Switch will reset at a lower pressure. Dial markings are a guide for setting. Actual setting should be checked with a good pressure gage.

**Warning:** A failure resulting in injury or damage may be caused by over-pressures, excessive vibration or pressure pulsation, excessive temperature, corrosion of pressure-containing parts and movement assembly, electrical overload or other misuse.

#### SPECIFICATIONS

**Wetted Materials:** Aluminum pressure chamber with polyimide diaphragm or 316 SS pressure chamber with FEP diaphragm.

**Temperature Limits:** -30 to 170°F (-35 to 77°C).

**Enclosure Rating:** Explosion-proof, UL listed for Class 1, Groups A, B, C and D; Class II, Groups E, F and G.

**Switch Type:** SPDT snap switch. Hermetically sealed optional.

**Electrical Rating:** 15A @ 125/250/480 VAC resistive; 0.5A @ 125 VDC, 0.25A @ 250 VDC.

**Wiring Connections:** 18 AWG, 18" (460 mm) color-coded leads: N.O. (yellow), N.C. (black) and common (red).

**Conduit Connection:** 1/2" male NPT.

**Process Connection:** 1/4" female NPT.

**Mounting Orientation:** Any position.

**Set Point Adjustment:** Internal thumbwheel.

**Weight:** 3 lb (1.4 kg).

**Deadband:** See chart

**Agency Approvals:** CE, UL.

**Note:** When used on steam, a pigtail siphon and Type 3 (FEP) diaphragm should be used. Maximum case ambient temperature: 170°F (76.7°C).

Operating Ranges/Deadband			
Range No.	psig (bar)	Approx. Deadband (fixed)* psig (bar)	Max. press. without bursting psig (bar)
3	5-40 (0.35 - 2.76)	2.5 (0.17)	3000 (206.7)
4	10-70 (0.69 - 4.82)	5 (0.34)	3000 (206.7)
5	25 - 200 (1.72 - 13.78)	10 (0.69)	3000 (206.7)
6	50 - 350 (3.45 - 24.12)	18 (1.2)	3000 (206.7)
7	75 - 550 (5.17 - 37.90)	36 (2.5)	3000 (206.7)
8	100 - 900 (6.89 - 62.01)	60 (4.1)	3000 (206.7)
9	200 - 1400 (13.78 - 96.46)	90 (6.2)	3000 (206.7)

\*Deadband is 10% larger when using 316SS diaphragm.

Electrical Rating										
Code	No. Switches Action	AC Capacity			DC Capacity		Horse Power			
							AC		DC	
		125V	250V	480V	125V	250V	125V	250V	125V	250V
J	1 Snap SPDT	15A	15A	15A	0.5A (2)	0.25A (2)	1/8	1/4	NA	NA

Note (2) Resistive